

APLIKACIJE

APLIKACIJE - Centrifugalne monoblok jednostepene električne pumpe konstruirane prema EN 733 standardima idealne su za pumpanje čiste vode i drugih kemijskih i mehanički neagresivnih tekućina. Ovaj sustav može biti instaliran u bilo kojem položaju i zahvaljujući svojim posebnim dizajnom omogućuje lagano izvlačenje motora i okretnih dijelova pumpe te ponovnu montažu bez uklanjanja tijela pumpe koje je spojeno na usisni te tlačni cijevovod. Koriste se za razne namjene u građanskim, poljoprivrednim i industrijskim sektorima. Opskrba vodom kod navodnjavanja sistemom prskanja ili kap na kap ; hidroforskih sistema ; protupožarnih sistema ; visokotlačnih sistema ; sistema grijanja i klimatizacije... Standardno se isporučuju sa kontra prirubicama.

TEHN. KARAKTERISTIKE

- Max. radni tlak 10 bara
- Temp. tekućine od -10 do 90 °C

MOTOR

- Dvopolni (n= 2850 o/min)
- Klasa izolacije F
- Zaštita IP 55

MATERIJALI

Tijelo pumpe: ljevano željezo
Lanterna motora: ljevano željezo
Rotor pumpe (lopatica) : ljevano željezo ili bronca
Osovina: inox
Mehanička brtva: keramika / grafit

TIP PUMPE	P2 nom.		P1 max (kW)	I 3x400V 50 Hz																	
	(HP)	(kW)			0	4,5	6	7,5	9	12	15	18	21	24	27	30	33	36			
					0	75	100	125	150	200	250	300	350	400	450	500	550	600			
CM 32-160C (*)	2	1,5	2,3	4	24,7	24,4	24,1	23,6	23	21,5	19,6	17,2	14,1								
CM 32-160B (*)	3	2,2	2,9	5,2	29		28,5	28	27,3	25,7	23,8	21,4	18,5	14,8							
CM 32-160A	4	3	4,1	7,1	36,8		36,4	36	35,4	34,2	32,8	31,1	28,8	26	22,3						
CM 32-200C (*)	5,5	4	5,2	9,4	41,0		40,0	39,5	38,9	37,5	36,0	34,2	32,2	30,0	27,0						
CM 32-200B1	7,5	5,5	6,6	11,3	48,0		47,5	47,1	46,6	45,5	44,3	42,5	40,7	38,5	35,7	32,5	28,6				
CM 32-200B	7,5	5,5	8	13,7	52,8		52,0	51,5	51,0	50,0	48,5	46,8	45,0	42,7	40,1	37,0	33,3	28,7			
CM 32-200A1	10	7,5	8,5	14,6	56,5		56,0	55,6	55,2	54,0	52,8	51,0	49,2	47,0	44,2	41,0	37,1	33,0			
CM 32-200A	10	7,5	9,9	16,5	61,0		60,5	60,1	59,6	58,5	57,2	55,5	53,7	51,5	49,0	46,2	42,7	38,5			
CM 32-250C	12,5	9,2	11,9	20,1	70			68,5	68,0	67,0	65,5	63,5	61,5	58,7	55	50,5					
CM 32-250B	15	11	14,4	24,2	82			81,0	80,5	79,5	78,5	77,0	75	72,6	70	66,5					
CM 32-250A1	20	15	16	27,4	91,0			90,0	89,9	89,0	88,0	86,0	84,0	81,5	79,0	75,5					
CM 32-250A	20	15	18,1	30,1	93,0			92,5	92,0	91,5	90,5	89,5	88,0	85,7	83,5	80,0					
CM 40-125C (*)	2	1,5	2,3	4	17,4			17,6	17,5	17,3	16,9	16,4	15,8	15,1	14,2	13,3					
CM 40-125B (*)	3	2,2	2,9	5,2	20,7				21,3	21,2	21,0	20,6	20,1	19,4	18,7	17,9	17,0				
CM 40-125A	4	3	4,1	7,1	25,2				25,8	25,8	25,6	25,4	24,9	24,4	23,7	22,9	22,0	21,1			
CM 40-160B (*)	4	3,0	4,4	7,4	30,0				30,1	30,0	29,6	29,0	28,2	27,1	25,9	24,4	22,8	21,0			
CM 40-160A (*)	5,5	4,0	5,7	9,9	35,4				35,6	35,5	35,3	35,0	34,2	33,2	32,0	30,6	29,0	27,3			
CM 40-200B1	7,5	5,5	6,5	11,1	42,2				42,4	42,3	42,1	41,3	40,3	39,1	37,5	35,5	33,3	30,7			
CM 40-200B	7,5	5,5	7,4	12,7	44,7				44,9	44,8	44,6	44,0	42,9	41,6	40,0	38,1	36,1	33,6			
CM 40-200A1	10	7,5	8,1	13,8	49,7				49,7	49,7	49,4	48,7	47,9	46,6	45,0	43,2	41,1	38,6			
CM 40-200A	10	7,5	9,8	16,5	57,7				57,7	57,5	57,1	56,3	55,4	54,1	52,5	50,5	48,5	45,9			
CM 40-250C	12,5	9,2	12,6	21	65,0				64,3	63,9	63,3	62,6	61,5	60,2	58,8	56,9	54,5	51,6			
CM 40-250B	15	11,0	14,4	24,2	75,5				74,6	74,2	73,5	72,7	71,7	70,4	69,0	67,2	65,0	62,5			
CM 40-250A1	20	15	17,5	29,5	85				84,0	83,7	82,9	82,1	80,8	79,5	77,8	75,9	73,8	71,3			
CM 40-250A	20	15,0	19,0	32,0	91,5				90,4	89,9	89,3	88,5	87,5	86,6	85,5	84,0	82,5	80,5			
CM 50-125B (*)	4	3	4,2	7,1	19,8					20,2	20,2	20,1	20,0	19,8	19,5	19,3	18,8	18,5			
CM 50-125A (*)	5,5	4	5,5	9,6	24,8					25,2	25,2	25,1	25,0	24,8	24,6	24,3	23,9	23,5			
CM 50-160B1	7,5	5,5	6,2	10,7	29,3								30,3	30,2	30,0	29,6	29,0	28,4			
CM 50-160B	7,5	5,5	6,7	11,6	31,1								32,1	32,0	31,7	31,4	31,0	30,4			
CM 50-160A1	10	7,5	8,3	14,1	34,3								35,4	35,3	35,0	34,7	34,3	33,8			
CM 50-160A	10	7,5	9,4	15,8	36,7								37,9	37,8	37,7	37,4	37,1	36,6			
CM 50-200C	12,5	9,2	10,8	18,5	46,0									45,6	45,1	44,5	43,7	42,9			
CM 50-200B	15	11	12,4	21	50,8									51,0	50,5	50,0	49,3	48,5			
CM 50-200A1	20	15	14,5	25,4	57,0									57,3	57,1	56,7	56,2	55,6			
CM 50-200A	20	15	15,4	27	58,0									58,3	58,0	57,5	57,0	56,4			
CM 50-250C	20	15	20	32,5	71,5										70,8	70,3	69,7	69,0			
CM 50-250B	25	18,5	23	41,5	78,0										78,0	77,4	76,8	76,1			
CM 50-250A	30	22	28,5	51,5	90,0										89,5	88,8	88,3	87,7			
CM 65-125B1	7,5	5,5	6,4	11	19,4											20,4	20,4	20,3			
CM 65-125B	7,5	5,5	7,2	12,6	20,9											22,0	22,0	21,9			
CM 65-125A1	10	7,5	8,1	14	23											24,1	24,1	24,0			
CM 65-125A	10	7,5	9,5	16,3	25,4											26,4	26,4	26,4			
CM 65-160C	12,5	9,2	11,7	19,5	29,8																
CM 65-160B	15	11,0	13,0	22,5	33,0																
CM 65-160A1	20	15	15,8	27,6	37,1																
CM 65-160A	20	15,0	18,0	30,0	39,2																
CM 65-200C1	20	15	17,1	28,8	43,1																
CM 65-200C	20	15	18,6	31,4	45,3																
CM 65-200B	25	18,5	22,6	38,2	51,6																
CM 65-200A	30	22,5	26,6	43,8	60,2																
CM 65-250B	40	30	37,8	63,5	81,0																
CM 65-250A	50	37	45	74,5	90,0																
CM 80-160E	12,5	9,2	9,9	17,2	21,4																
CM 80-160D	15	11	12,7	22,1	25,4																
CM 80-160C1	20	15	14,8	25,5	28,5																
CM 80-160C	20	15	15,9	27,4	29,7																
CM 80-160B	25	18,5	20,1	34,8	34																
CM 80-160A	30	22,5	23,7	39,8	38,8																
CM 80-200B	40	30	37,8	63,5	49,0																
CM 80-200A	50	37	45	74,5	58,0																

(*) Dostupni jednofazni modeli

CM 32-160

CM 32-200

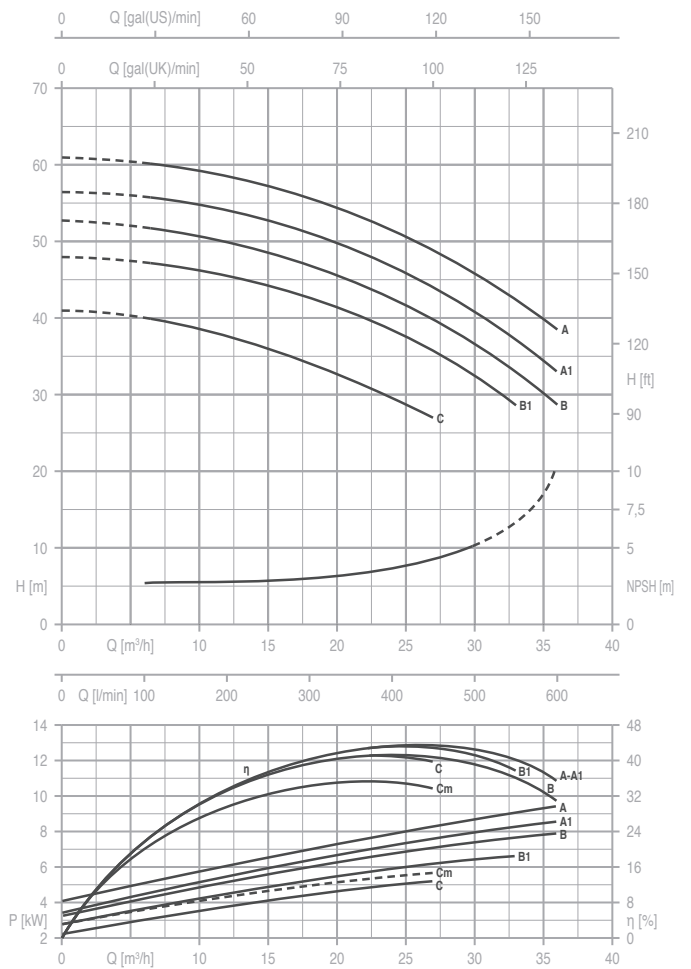
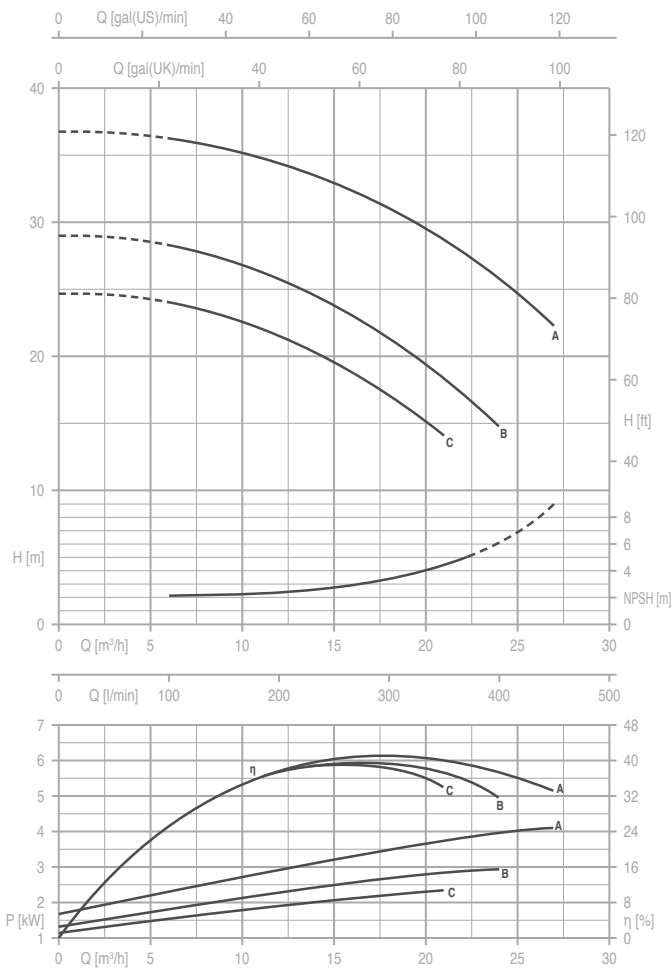

TYPE	P2		P1 (kW)	AMPERA	Q = KAPACITET (PROTOK) Q (m³/h - l/min)										
					3~										
					0	4.5	6	7.5	9	12	15	18	21	24	27
3~			3~	3~	0	75	100	125	150	200	250	300	350	400	450
	(HP)	(kW)		3x400 V 50 Hz	Visina dobave u metrima H (m)										
CM 32-160 C (*)	2	1.5	2.3	4	24.7	24.4	24.1	23.6	23.0	21.5	19.6	17.2	14.1	-	-
CM 32-160 B (*)	3	2.2	2.9	5.2	29.0	-	28.5	28.0	27.3	25.7	23.8	21.4	18.5	14.8	-
CM 32-160 A	4	3	4.1	7.1	36.8	-	36.4	36.0	35.4	34.2	32.8	31.1	28.8	26.0	22.3

(*) Dostupni jednofazni modeli

TYPE	P2		P1 (kW)	AMPERA	Q = KAPACITET (PROTOK) Q (m³/h - l/min)												
					3~												
					0	6	7.5	9	12	15	18	21	24	27	30	33	36
3~			3~	3~	0	100	125	150	200	250	300	350	400	450	500	550	600
	(HP)	(kW)		3x400 V 50 Hz	Visina dobave u metrima H (m)												
CM 32-200 C (*)	5.5	4	5.2	9.4	41	40	39,5	38,9	37,5	36	34,2	32,2	30	27	-	-	-
CM 32-200 B1	7.5	5.5	6.6	11.3	48	47,5	47,1	46,6	45,5	44,3	42,5	40,7	38,5	35,7	32,5	28,6	24,5
CM 32-200 B	7.5	5.5	8.0	13.7	52,8	52	51,5	51	50	48,5	46,8	45	42,7	40,1	37	33,3	28,7
CM 32-200 A1	10	7.5	8.5	14.6	56,5	56	55,6	55,2	54	52,8	51	49,2	47	44,2	41	37,1	33
CM 32-200 A	10	7.5	9.9	16.5	61	60,5	60,1	59,6	58,5	57,2	55,5	53,7	51,5	49	46,2	42,7	38,5

(*) Dostupni jednofazni modeli

CM 32-250

CM 40-125

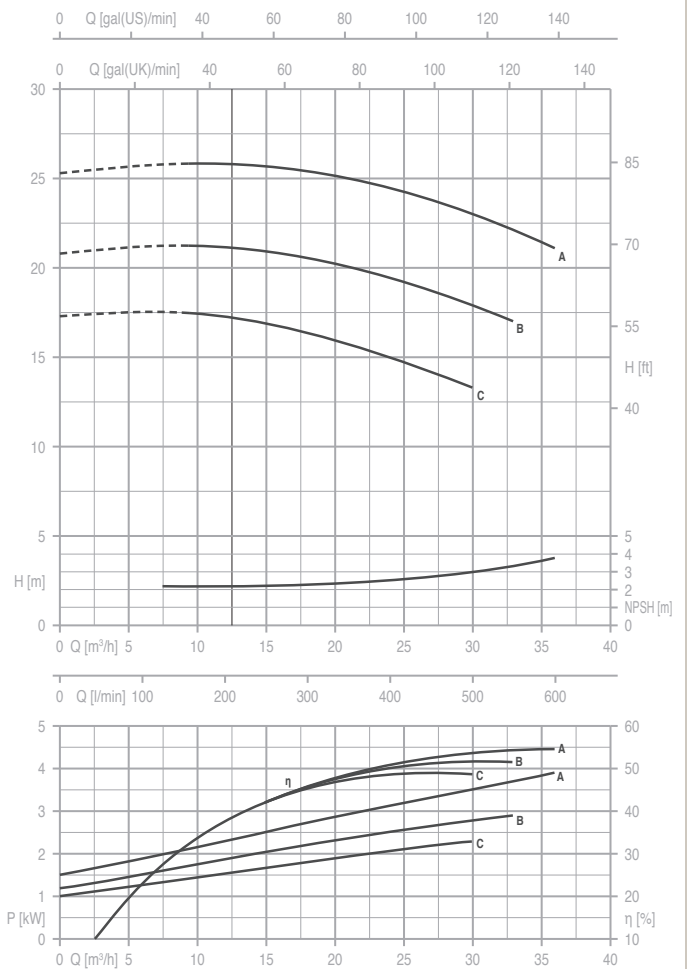
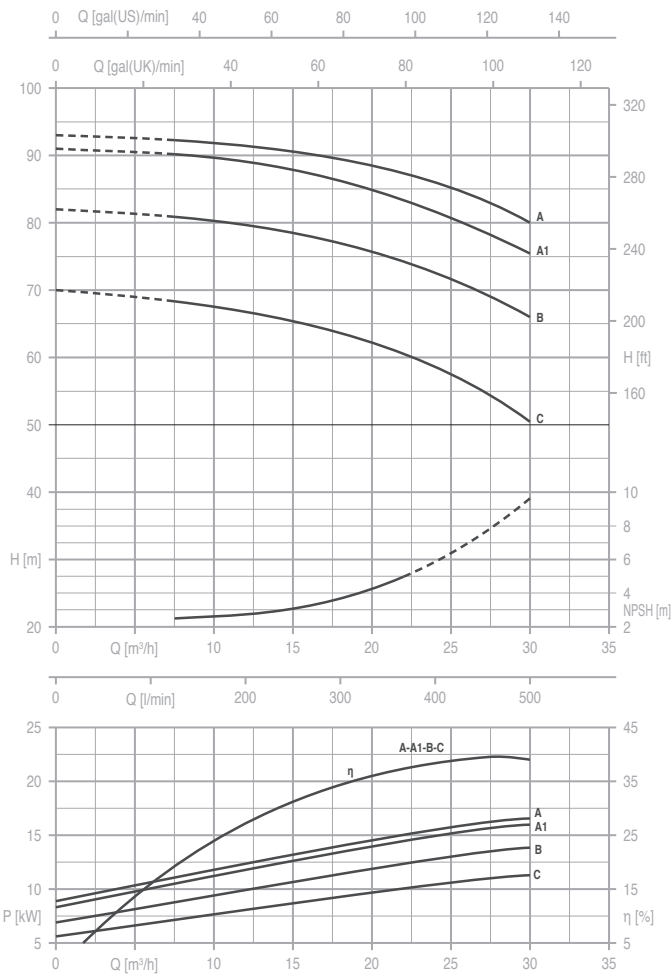

TIP PUMPE	P2		P1 (kW)	AMPERA	Q = KAPACITET (PROTOK) Q (m³/h - l/min)										
					3~	0	7.5	9	12	15	18	21	24	27	30
						0	125	150	200	250	300	350	400	450	500
3~			3~	3x400 V 50 Hz	Visina dobave u metrima H (m)										
CM 32-250 C	12.5	9.2	11.9	20.1	70.0	68,5	68	67	65,5	63,5	61,5	58,7	55	50,5	
CM 32-250 B	15	11	14.4	24.2	82.0	81	80,5	79,5	78,5	77	75	72,6	70	66,5	
CM 32-250 A1	20	15	16	27.4	91.0	90	89,9	89	88	86	84	81,5	79	75,5	
CM 32-250 A	20	15	18.1	30.1	93.0	92,5	92	91,5	90,5	89,5	88	85,7	83,5	80	

TIP PUMPE	P2		P1 (kW)	AMPERA	Q = KAPACITET (PROTOK) Q (m³/h - l/min)												
					3~	0	7.5	9	12	15	18	21	24	27	30	33	36
						0	125	150	200	250	300	350	400	450	500	550	600
3~			3~	3x400 V 50 Hz	Visina dobave u metrima H (m)												
CM 40-125 C (*)	2	1.5	2.3	4.0	17.4	17.6	17.5	17.3	16.9	16.4	15.8	15.1	14.2	13.3	-	-	
CM 40-125 B (*)	3	2.2	2.9	5.2	20.7	-	21.3	21.2	21.0	20.6	20.1	19.4	18.7	17.9	17.0	-	
CM 40-125 A	4	3	4.1	7.1	25.2	-	25.8	25.8	25.6	25.4	24.9	24.4	23.7	22.9	22.0	21.1	

(*) Dostupni jednofazni modeli

CM 40-160

CM 40-200

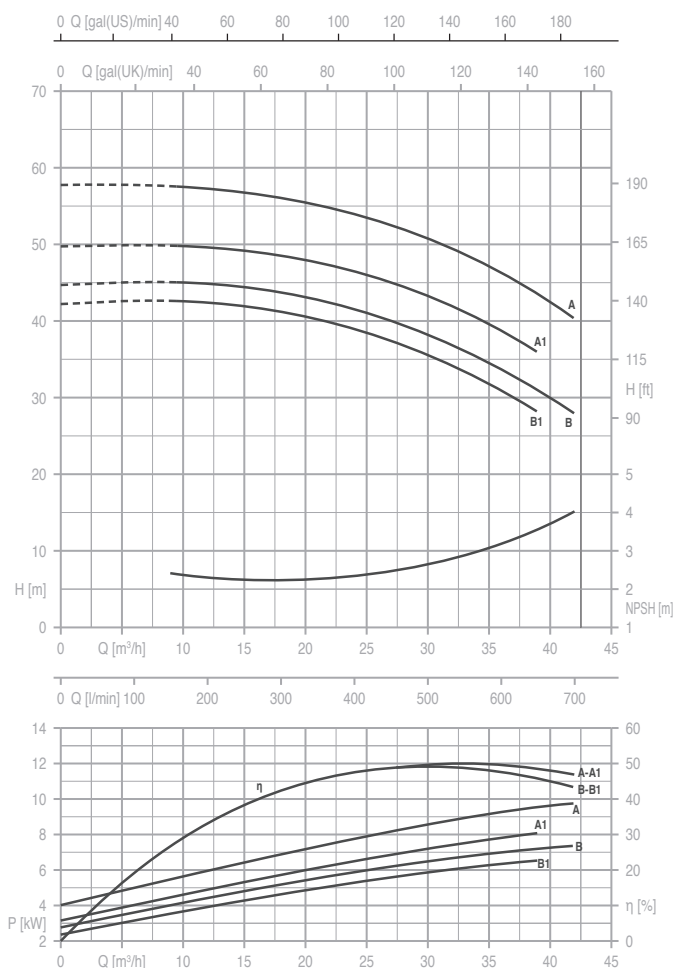
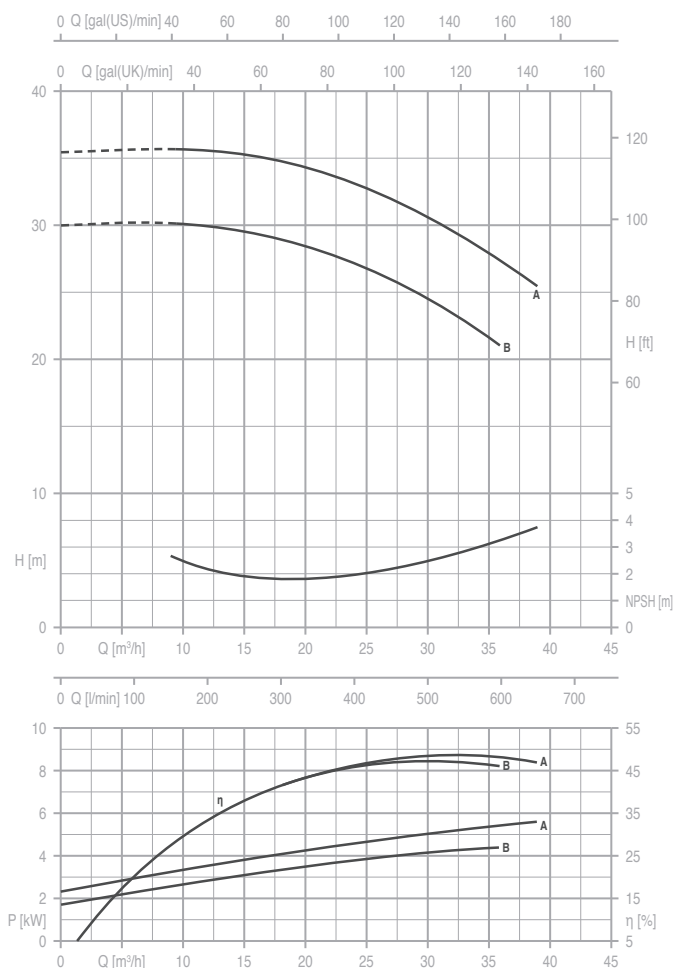

TIP PUMPE	P2		P1 (kW)	AMPERA	Q = KAPACITET (PROTOK) Q (m³/h - l/min)													
					3~	0	9	12	15	18	21	24	27	30	33	36	39	
						0	150	200	250	300	350	400	450	500	550	600	650	
3~	(HP)	(kW)	3~	3x400 V 50 Hz	Visina dobave u metrima H (m)													
CM 40-160 B (*)	4	3	4.4	7.4	30.0	30.1	30.0	29.6	29.0	28.2	27.1	25.9	24.4	22.8	21.0	-		
CM 40-160 A (*)	5.5	4	5.7	9.9	35.4	35.6	35.5	35.3	35.0	34.2	33.2	32.0	30.6	29.0	27.3	25.4		

(*) Dostupni jednofazni modeli

TIP PUMPE	P2		P1 (kW)	AMPERA	Q = KAPACITET (PROTOK) Q (m³/h - l/min)															
					3~	0	9	12	15	18	21	24	27	30	33	36	39	42		
						0	150	200	250	300	350	400	450	500	550	600	650	700		
3~	(HP)	(kW)	3~	3x400 V 50 Hz	Visina dobave u metrima H (m)															
CM 40-200 B1	7.5	5.5	6.5	11.1	42.2	42.4	42.3	42.1	41.3	40.3	39.1	37.5	35.5	33.3	30.7	28.0	-			
CM 40-200 B	7.5	5.5	7.4	12.7	44.7	44.9	44.8	44.6	44.0	42.9	41.6	40.0	38.1	36.1	33.6	30.8	27.9			
CM 40-200 A1	10	7.5	8.1	13.8	49.7	49.7	49.7	49.4	48.7	47.9	46.6	45.0	43.2	41.1	38.6	35.9	-			
CM 40-200 A	10	7.5	9.8	16.5	57.7	57.7	57.5	57.1	56.3	55.4	54.1	52.5	50.5	48.5	45.9	43.3	40.3			

CM 40-250

CM 50-125

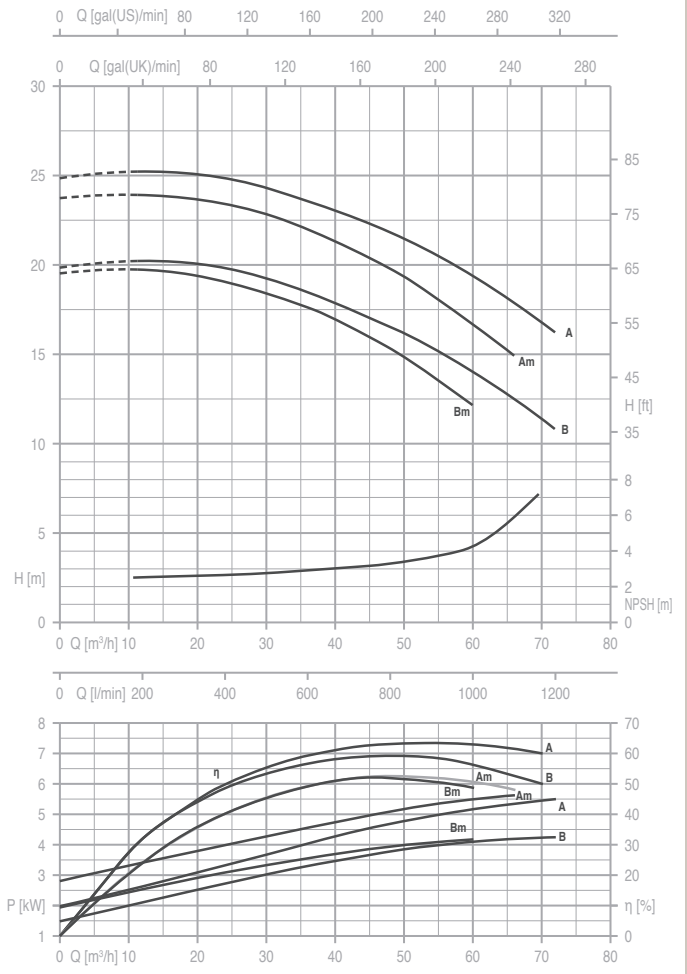
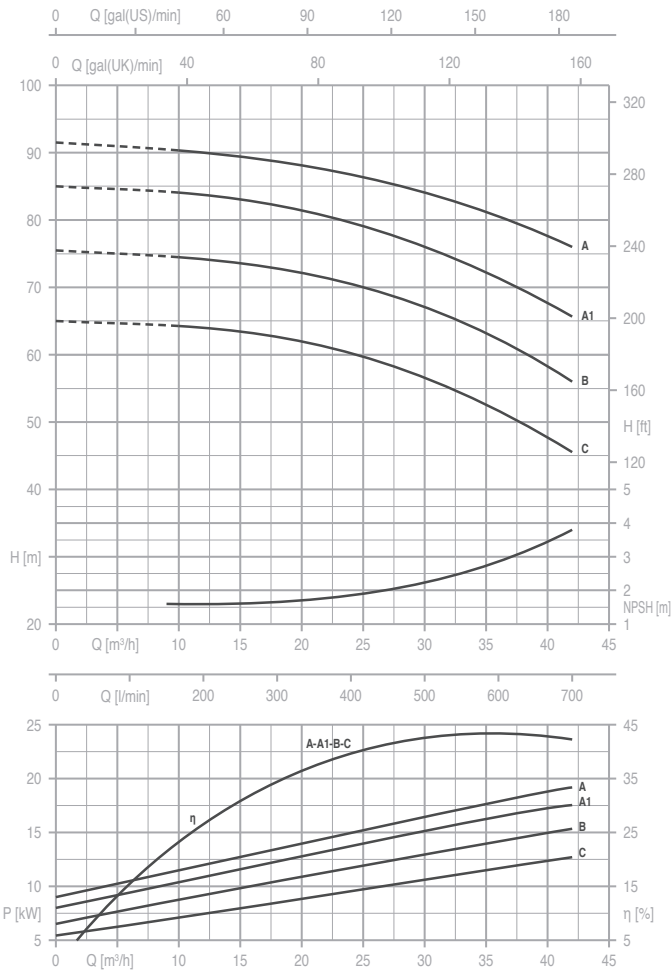

TIP PUMPE		P2		P1 (kW)	AMPERA		Q = KAPACITET (PROTOK) Q (m³/h - l/min)													
3~	3~				3~		Visina dobave u metrima H (m)													
		(HP)	(kW)	3~	0	9	12	15	18	21	24	27	30	33	36	39	42			
CM 40-250 C	12,5	9,2	12,6	21,0	65,0	64,3	63,9	63,3	62,6	61,5	60,2	58,8	56,9	54,5	51,6	48,5	45,5			
CM 40-250 B	15	11,0	14,4	24,2	75,5	74,6	74,2	73,5	72,7	71,7	70,4	69	67,2	65	62,5	59,5	56			
CM 40-250 A1	20	15	17,5	29,5	85,0	84	83,7	82,9	82,1	80,8	79,5	77,8	75,9	73,8	71,3	68,4	65,8			
CM 40-250 A	20	15	19,0	32,0	91,5	90,4	89,9	89,3	88,5	87,5	86,6	85,5	84	82,5	80,5	78,5	76			

TIP PUMPE		P2		P1 (kW)		AMPERA		Q = KAPACITET (PROTOK) Q (m³/h - l/min)																	
1~	3~					1~ 3~		Visina dobave u metrima H (m)																	
		(HP)	(kW)	1~	3~	0	12	15	18	21	24	27	30	33	36	39	42	48	54	60	66	72			
-	CM 50-125 B	4	3	-	4,25	-	7,1	19,8	20,2	20,2	20,1	20	19,8	19,5	19,3	18,8	18,5	18	17,6	16,5	15,3	14	12,5	10,8	
CM 50-125 B m	-			4,2	-	18,4	-	19,5	19,7	19,6	19,5	19,3	19	18,7	18,4	18	17,6	17,1	16,6	15,3	13,8	12,1	-	-	
-	CM 50-125 A	5,5	4	-	5,5	-	9,6	24,8	25,2	25,2	25,1	25	24,8	24,6	24,3	23,9	23,5	23,2	22,7	21,8	20,7	19,4	17,9	16,2	
CM 50-125 A m	-			5,6	-	25,4	-	23,7	23,9	23,8	23,7	23,6	23,4	23,1	22,8	22,4	22	21,5	20,9	19,7	18,3	16,7	14,9	-	

CM 50-160

CM 50-200

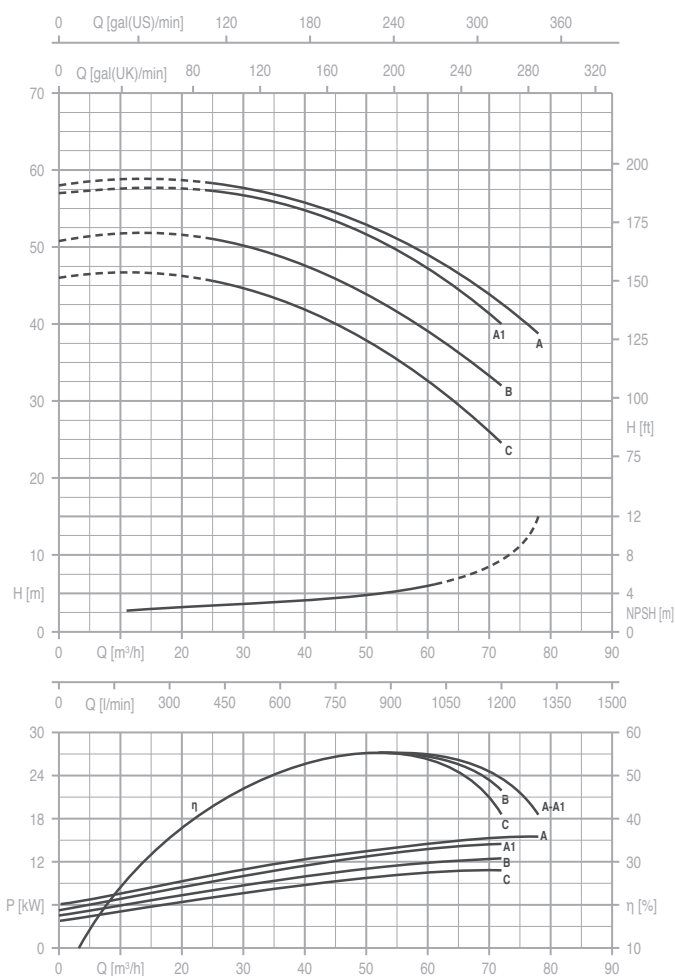
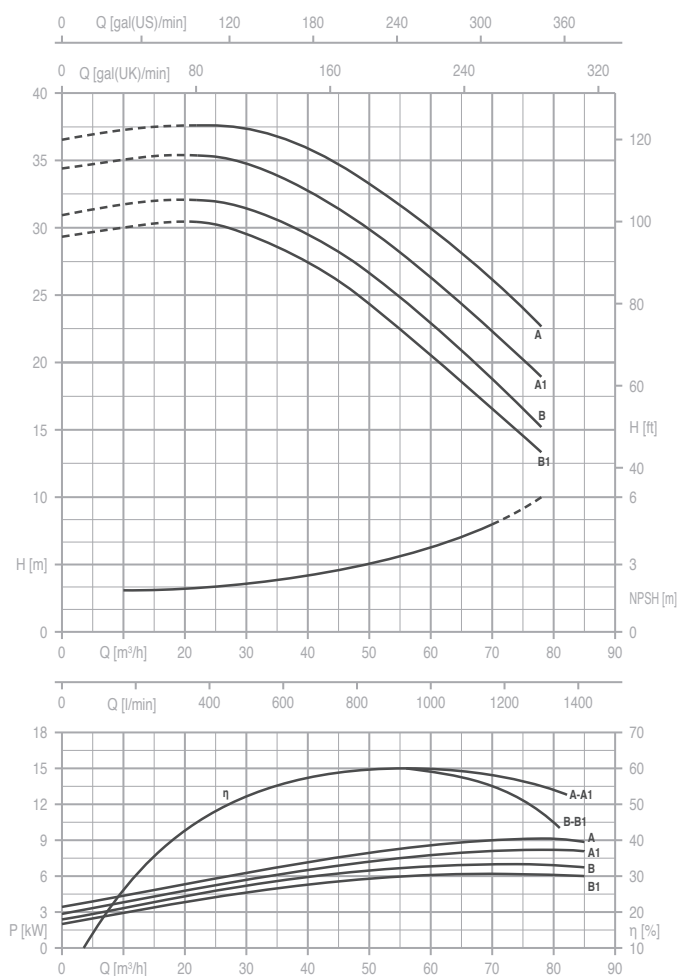

TIP PUMPE	P2		P1 (kW)	AMPERA	Q = KAPACITET (PROTOK) Q (m³/h - l/min)															
					3~	0	21	24	27	30	33	36	39	42	48	54	60	66	72	78
						0	350	400	450	500	550	600	650	700	800	900	1000	1100	1200	1300
3~	(HP)	(kW)	3~	3x400 V 50 Hz	Visina dobave u metrima H (m)															
CM 50-160 B1	7.5	5.5	6.2	10.7	29,3	30,3	30,2	30	29,6	29	28,4	27,7	26,9	25,2	23,2	21	18,7	16,1	13,2	
CM 50-160 B	7.5	5.5	6.7	11.6	31,1	32,1	32	31,7	31,4	31	30,4	29,7	28,9	27,3	25,3	23,1	20,7	18	15,2	
CM 50-160 A1	10	7.5	8.3	14.1	34,3	35,4	35,3	35	34,7	34,3	33,8	33,2	32,4	30,7	28,7	26,5	24,3	21,8	19	
CM 50-160 A	10	7.5	9.4	15.8	36,7	37,9	37,8	37,7	37,4	37,1	36,6	36,1	35,4	33,9	32,1	30	27,8	25,3	22,6	

TIP PUMPE	P2		P1 (kW)	AMPERA	Q = KAPACITET (PROTOK) Q (m³/h - l/min)															
					3~	0	24	27	30	33	36	39	42	48	54	60	66	72	78	
						0	400	450	500	550	600	650	700	800	900	1000	1100	1200	1300	
3~	(HP)	(kW)	3~	3x400 V 50 Hz	Visina dobave u metrima H (m)															
CM 50-200 C	12.5	9.2	10.8	18.5	46	45,6	45,1	44,5	43,7	42,9	41,8	40,8	38,5	35,9	33	29	24,5	-		
CM 50-200 B	15	11	12.4	21.0	50,8	51	50,5	50	49,3	48,5	47,7	46,8	44,7	42,2	39,5	35,9	32	-		
CM 50-200 A1	20	15	14.5	25.4	57	57,3	57,1	56,7	56,2	55,6	54,8	54,1	52,2	50,2	47,5	44	40	-		
CM 50-200 A	20	15	15.4	27.0	58	58,3	58	57,5	57	56,4	55,7	55	53,2	51,3	49	46,3	42,8	38,8		

CM 50-250

CM 65-125

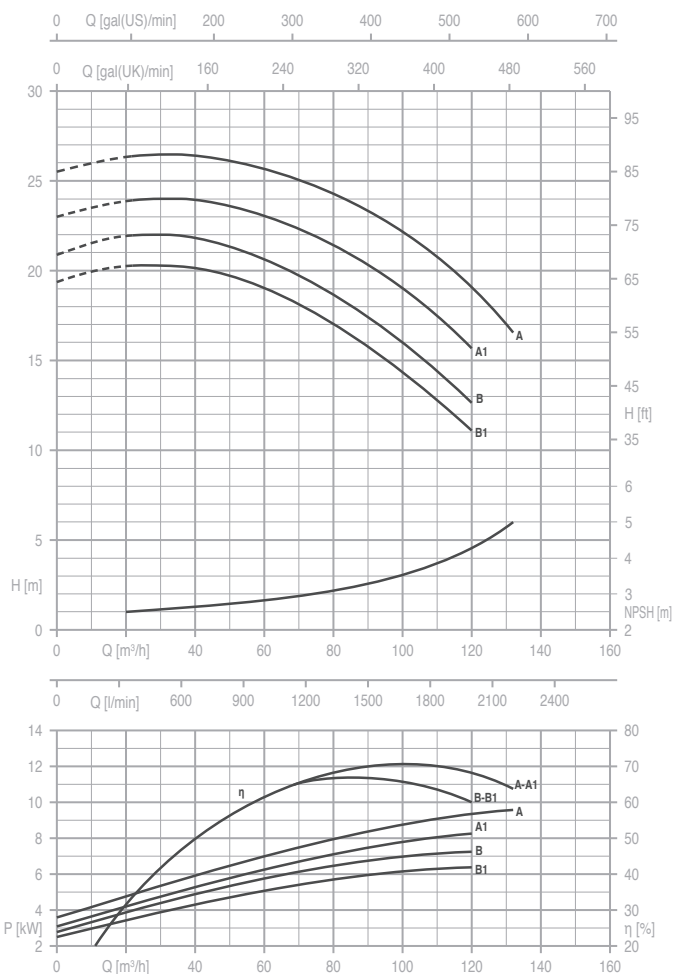
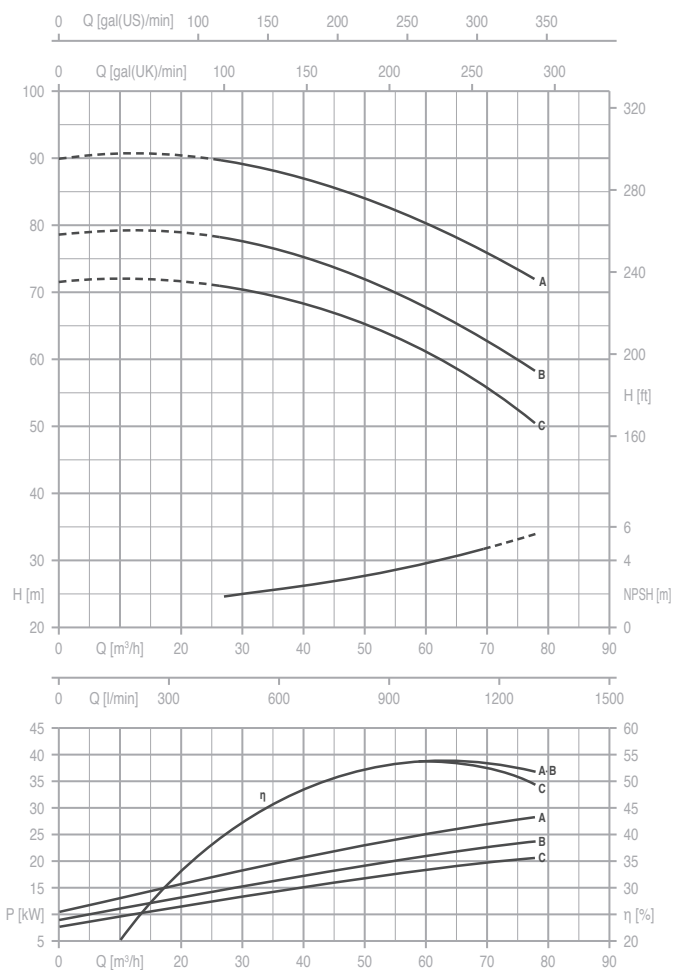

TIP PUMPE	P2		P1 (kW)	AMPERA	Q = KAPACITET (PROTOK) Q (m³/h - l/min)													
					3~													
					3x400 V 50 Hz													
3~	(HP)	(kW)	3~	Visina dobave u metrima H (m)														
CM 50-250 C	20	15	20	32.5	71.5	70,8	70,3	69,7	69	68,3	67,6	66	64	61,5	58,6	55	50,5	
CM 50-250 B	25	18.5	23	41.5	78.0	78	77,4	76,8	76,1	75,3	74,5	72,8	70,6	68,2	65,5	62,2	58,3	
CM 50-250 A	30	22.5	28.5	51.5	90	89,5	88,8	88,3	87,7	86,9	86,1	84,5	82,7	80,5	78	75,2	71,7	

TIP PUMPE	P2		P1 (kW)	AMPERA	Q = KAPACITET (PROTOK) Q (m³/h - l/min)																	
					3~																	
					3x400 V 50 Hz																	
3~	(HP)	(kW)	3~	Visina dobave u metrima H (m)																		
CM 65-125 B1	7.5	5.5	6.4	11	19,4	20,4	20,4	20,3	20,2	20,1	19,8	19,4	19	18,5	17,9	17,2	16,5	15	13,3	11,1	-	
CM 65-125 B	7.5	5.5	7.2	12.6	20,9	22	22	21,9	21,8	21,7	21,4	21	20,6	20,1	19,6	19	18,3	16,6	14,7	12,6	-	
CM 65-125 A1	10	7.5	8.1	14	23	24,1	24,1	24	23,9	23,8	23,6	23,3	23	22,7	22,3	21,8	21,2	19,7	17,8	15,7	-	
CM 65-125 A	10	7.5	9.5	16.3	25,4	26,4	26,4	26,4	26,3	26,3	26,1	25,9	25,6	25,3	24,9	24,5	24	22,7	21	18,9	16,5	

CM 65-160

CM 65-200

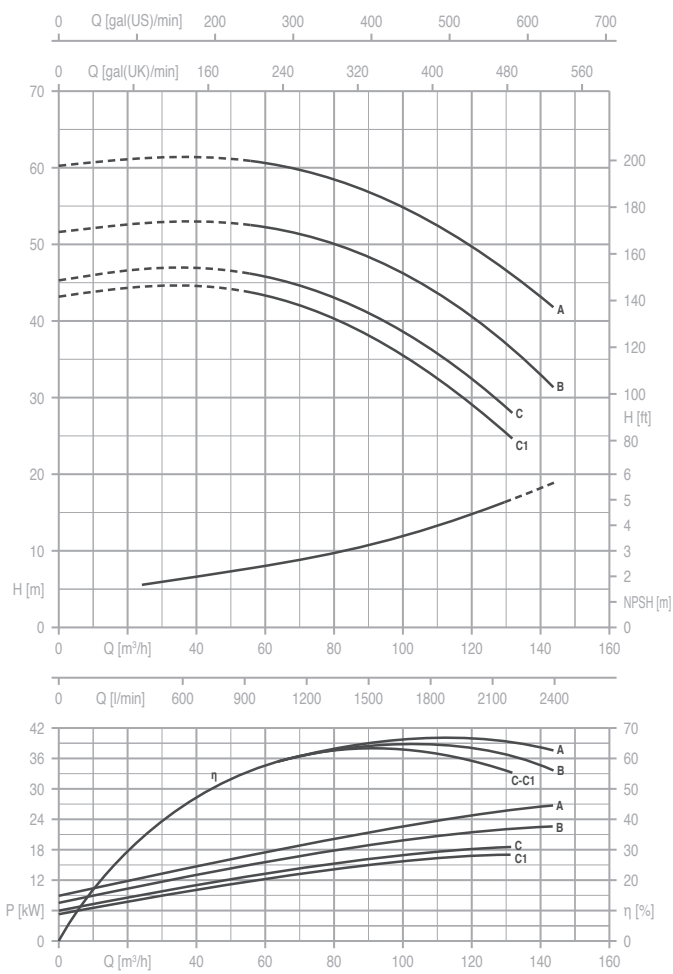
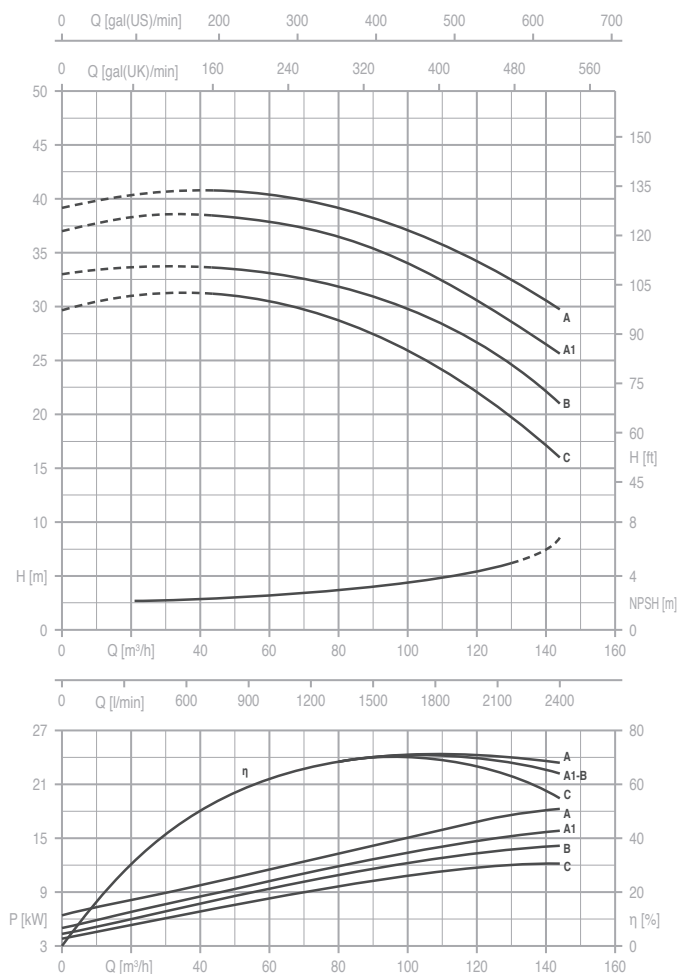

TIP PUMPE	P2		P1 (kW)	AMPERA	Q = KAPACITET (PROTOK) Q (m³/h - l/min)														
					3~	0	42	48	54	60	66	72	78	84	96	108	120	132	144
						0	700	800	900	1000	1100	1200	1300	1400	1600	1800	2000	2200	2400
3~	(HP)	(kW)	3~	3x400 V 50 Hz	Visina dobave u metrima H (m)														
CM 65-160 C	12.5	9.2	11.7	19.5	29,8	31,2	31,1	30,8	30,5	30,1	29,6	29	28,3	26,6	24,6	22,1	19,3	16	
CM 65-160 B	15	11	13	22.5	33	34,6	34,4	34,2	34	33,7	33,3	32,8	32,1	30,6	28,8	26,7	24,1	21,1	
CM 65-160 A1	20	15	15.8	27.6	37,1	38,5	38,3	38,1	37,8	37,5	37,1	36,7	36,1	34,6	32,8	30,7	28,4	25,7	
CM 65-160 A	20	15	18	30.0	39,2	40,6	40,6	40,4	40,2	40	39,7	39,4	38,9	37,7	36,2	34,3	32,2	29,8	

TIP PUMPE	P2		P1 (kW)	AMPERA	Q = KAPACITET (PROTOK) Q (m³/h - l/min)													
					3~	0	54	60	66	72	78	84	96	108	120	132	144	
						0	900	1000	1100	1200	1300	1400	1600	1800	2000	2200	2400	
3~	(HP)	(kW)	3~	3x400 V 50 Hz	Visina dobave u metrima H (m)													
CM 65-200 C1	20	15	17.1	28.8	43.1	43.8	43.2	42.5	41.7	40.6	39.5	36.8	33.4	29.3	24.5	-	-	-
CM 65-200 C	20	15	18.6	31.4	45.3	46.3	45.7	45.1	44.3	43.4	42.3	39.8	36.7	32.7	28.0	-	-	-
CM 65-200 B	25	18.5	22.6	38.2	51.6	52.6	52.2	51.8	51.0	50.2	49.3	47.1	44.1	40.9	36.6	31.3	-	-
CM 65-200 A	30	22.5	26.6	43.8	60.2	61.0	60.6	60.1	59.5	58.7	57.8	55.8	53.1	49.8	46.1	41.7	-	-

CM 65-250

CM 80-160

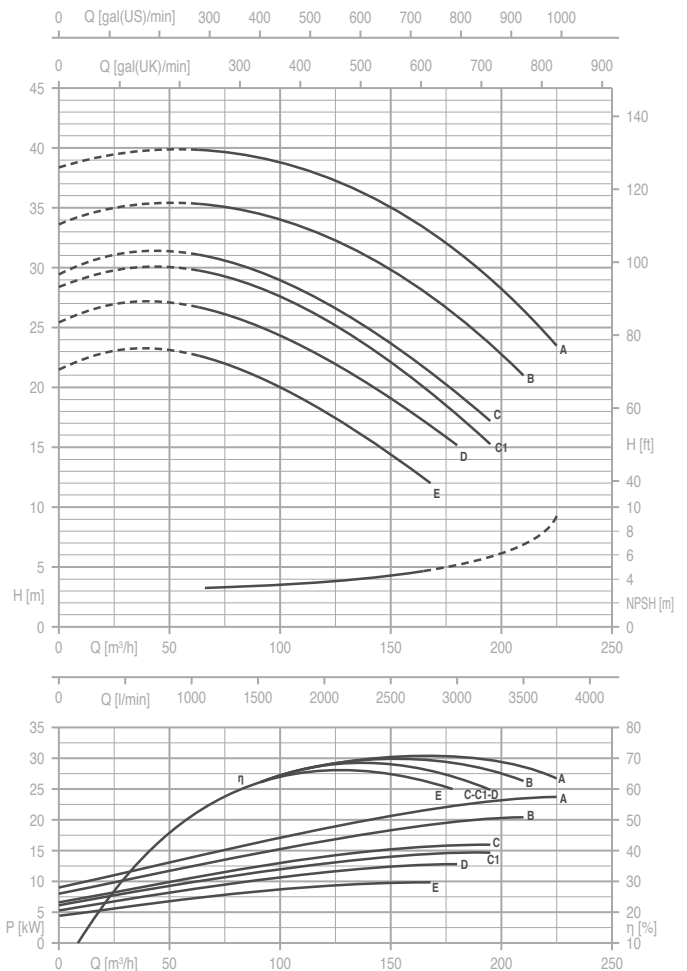
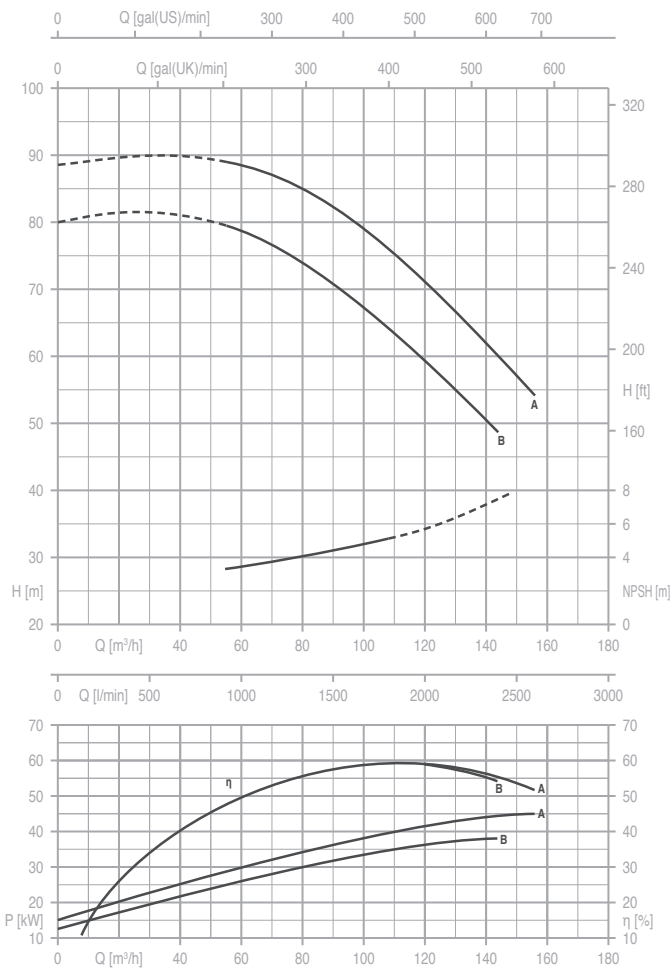

TIP PUMPE	P2		P1 (kW)	AMPERA	Q = KAPACITET (PROTOK) Q (m³/h - l/min)													
					Visina dobave u metrima H (m)													
					0	54	60	66	72	78	84	96	108	120	132	144	156	
3~	(HP)	(kW)	3~	3~	0	900	1000	1100	1200	1300	1400	1600	1800	2000	2200	2400	2600	
				3x400 V 50 Hz	81.0	79.5	78.5	77.3	76.0	74.5	73.0	69.3	65.0	60.0	54.5	48.5	-	
CM 65-250 B	40	30	37.8	63.5	74.5	90.0	89.5	88.5	87.5	86.5	85.5	84.0	80.5	76.5	72.0	66.5	60.5	54.0
CM 65-250 A	50	37	45	74.5	90.0	89.5	88.5	87.5	86.5	85.5	84.0	80.5	76.5	72.0	66.5	60.5	54.0	48.0

TIP PUMPE	P2		P1 (kW)	AMPERA	Q = KAPACITET (PROTOK) Q (m³/h - l/min)																	
					Visina dobave u metrima H (m)																	
					0	66	72	78	84	96	108	120	132	144	156	168	180	195	210	225		
3~	(HP)	(kW)	3~	3~	0	1100	1200	1300	1400	1600	1800	2000	2200	2400	2600	2800	3000	3250	3500	3750		
				3x400 V 50 Hz	21,4	22,4	22,1	21,6	21,2	20,2	19,2	18	16,8	15,4	13,7	12	-	-	-	-	-	
CM 80-160 E	12.5	9.2	9.9	17.2	21,4	22,4	22,1	21,6	21,2	20,2	19,2	18	16,8	15,4	13,7	12	-	-	-	-		
CM 80-160 D	15	11	12.7	22.1	25,4	26,4	26,1	25,7	25,3	24,4	23,6	22,5	21,3	20	18,5	16,9	15,1	-	-	-	-	
CM 80-160 C1	20	15	14.8	25.5	28,5	29,5	29,3	29	28,6	27,8	26,9	25,7	24,6	23,3	21,7	19,9	17,9	15,2	-	-	-	
CM 80-160 C	20	15	15.9	27.4	29,7	30,7	30,5	30,3	29,9	29,2	28,1	27,1	26	24,7	23,1	21,5	19,7	17,2	-	-	-	
CM 80-160 B	25	18.5	20.1	34.8	34	35	35	34,8	34,6	34	33,3	32,5	31,6	30,5	29,2	27,8	26	23,6	21	-	-	
CM 80-160 A	30	22.5	23.7	39.8	38,8	39,8	39,7	39,6	39,4	38,9	38,2	37,5	36,7	35,7	34,5	33,2	31,6	29,4	26,8	23,5	-	

CM 80-200

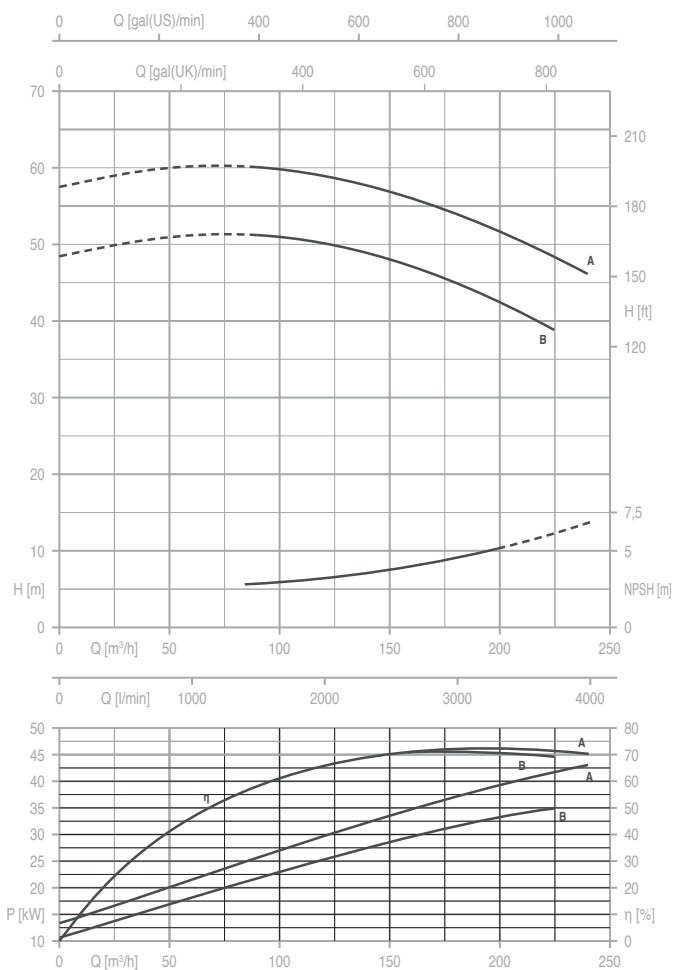



TIP PUMPE	P2		P1 (kW)	AMPERA	Q = KAPACITET (PROTOK) Q (m³/h - l/min)															
					3~	0	84	96	108	120	132	144	156	168	180	195	210	225	240	
						0	1400	1600	1800	2000	2200	2400	2600	2800	3000	3250	3500	3750	4000	
3~	(HP)	(kW)	3~	3x400 V 50 Hz	Visina dobave u metrima H (m)															
CM 80-200 B	40	30	37.8	63.5	49.0	50.8	50.6	50.3	49.8	49.3	48.6	47.7	46.7	45.5	44.8	41.6	38.6	-		
CM 80-200 A	50	37	45	74.5	58.0	-	59.6	59.2	58.6	58.0	57.3	56.4	55.5	54.3	52.7	50.8	48.5	46.1		

DIMENZIJE (mm)				
DN	D	K	RUPE	
			n°	Ø
32	140	100	4	18
40	150	110	4	18
50	165	125	4	18
65	185	145	4	18
80	200	160	4	18
100	220	180	8	18

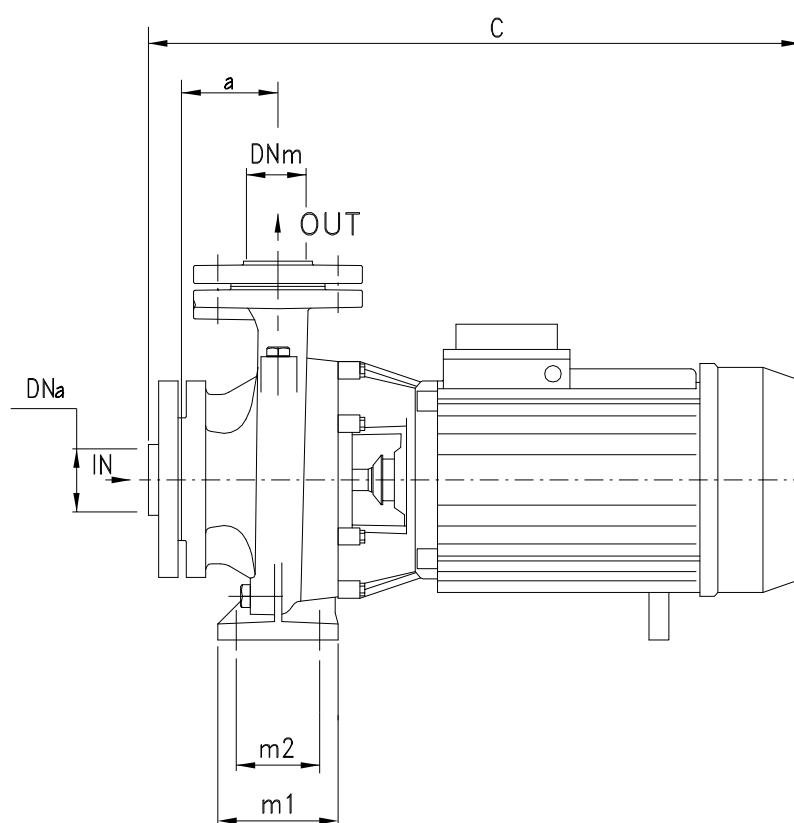
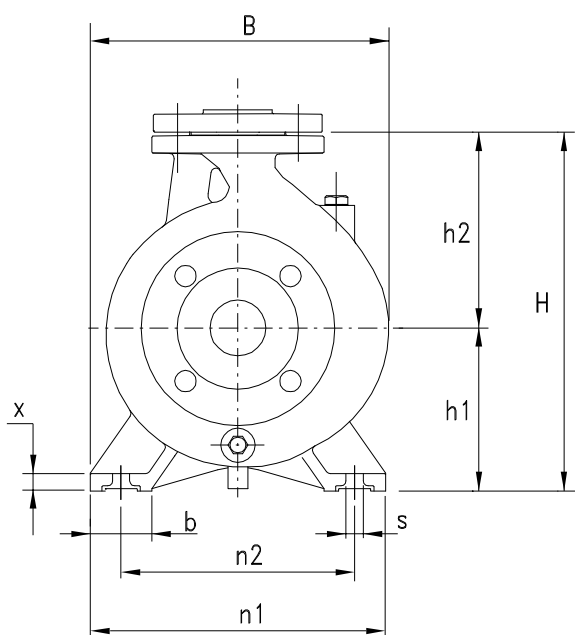
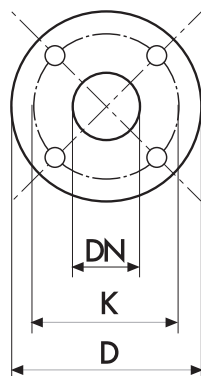
PRIRUBNICE

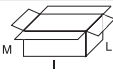

	TIP PUMPE	DIMENZIJE (mm)																		
		ULAZ		IZLAZ																
		DNm	DNa	a	h1	h2	m1	m2	n1	n2	b	x	s	C	B	H	I	L		
CM 32	CM 32-160 C	32	50	80	132	160	100	70	240	190	50	12	14	490	240	292	520	260	355	38
	CM 32-160 B	32	50	80	132	160	100	70	240	190	50	12	14	490	240	292	520	260	355	39
	CM 32-160 A	32	50	80	132	160	100	70	240	190	50	12	14	490	240	292	520	260	355	42
	CM 32-200 C	32	50	80	160	180	100	70	240	190	50	12	14	505	268	340	530	305	400	51.5
	CM 32-200 B1	32	50	80	160	180	100	70	240	190	50	12	14	520	268	340	615	310	460	61
	CM 32-200 B	32	50	80	160	180	100	70	240	190	50	12	14	565	268	340	615	310	460	63
	CM 32-200 A1	32	50	80	160	180	100	70	240	190	50	12	14	520	268	340	615	310	460	67
	CM 32-200 A	32	50	80	160	180	100	70	240	190	50	12	14	565	268	340	615	310	460	69
	CM 32-250 C	32	50	100	180	225	125	95	320	250	65	12	14	625	305	405	665	335	535	83
	CM 32-250 B	32	50	100	180	225	125	95	320	250	65	14	14	625	305	405	665	335	535	90
CM 32-250 A1	32	50	100	180	225	125	95	320	250	65	14	14	625	305	405	665	335	535	95	
CM 32-250 A	32	50	100	180	225	125	95	320	250	65	14	14	695	305	405	735	355	535	120	
CM 40	CM 40-125 C	40	65	80	112	140	100	70	210	160	50	12	14	495	220	252	520	260	355	36
	CM 40-125 B	40	65	80	112	140	100	70	210	160	50	12	14	495	220	252	520	260	355	37
	CM 40-125 A	40	65	80	112	140	100	70	210	160	50	12	14	495	220	252	520	260	355	40
	CM 40-160 B	40	65	80	132	160	100	70	240	190	50	12	14	500	245	292	520	260	355	47
	CM 40-160 A	40	65	80	132	160	100	70	240	190	50	15	14	500	245	292	520	260	355	50
	CM 40-200 B1	40	65	80	132	160	100	70	240	190	50	15	14	545	273	340	615	310	460	63
	CM 40-200 B	40	65	100	160	180	100	70	265	212	50	15	14	590	273	340	615	310	460	65
	CM 40-200 A1	40	65	80	132	160	100	70	240	190	50	15	14	545	273	340	615	310	460	69
	CM 40-200 A	40	65	100	160	180	100	70	265	212	50	15	14	590	273	340	615	310	460	71
	CM 40-250 C	40	65	100	180	225	125	95	320	250	65	15	14	630	322	405	665	335	535	84
	CM 40-250 B	40	65	100	180	225	125	95	320	250	65	15	14	630	322	405	665	335	535	91
	CM 40-250 A1	40	65	100	180	225	125	95	320	250	65	15	14	630	322	405	665	335	535	96
CM 40-250 A	40	65	100	180	225	125	95	320	250	65	15	14	700	322	405	735	355	535	121	
CM 50	CM 50-125 B	50	65	100	132	160	100	70	240	190	50	12	14	525	250	292	520	260	355	47
	CM 50-125 A	50	65	100	132	160	100	70	240	190	50	12	14	525	250	292	520	260	355	50
	CM 50-160 B1	50	65	100	150	180	100	70	265	212	50	12	14	545	270	340	615	310	460	63
	CM 50-160 B	50	65	100	150	180	100	70	265	212	50	12	14	590	270	340	615	310	460	65
	CM 50-160 A1	50	65	100	150	180	100	70	265	212	50	12	14	545	270	340	615	310	460	69
	CM 50-160 A	50	65	100	150	180	100	70	265	212	50	12	14	590	270	340	615	310	460	71
	CM 50-200 C	50	65	100	160	200	100	70	265	212	50	12	14	635	290	360	665	335	535	82
	CM 50-200 B	50	65	100	160	200	100	70	265	212	50	12	14	635	290	360	665	335	535	89
	CM 50-200 A1	50	65	100	160	200	100	70	265	212	50	12	14	635	290	360	665	335	535	94
	CM 50-200 A	50	65	100	160	200	100	70	265	212	50	12	14	705	290	360	735	355	535	122
	CM 50-250 C	50	65	100	180	225	125	95	320	250	65	14	14	705	332	405	735	355	535	125
	CM 50-250 B	50	65	100	180	225	125	95	320	250	65	14	14	750	332	405	815	355	535	140
CM 50-250 A	50	65	100	180	225	125	95	320	250	65	14	14	750	332	405	815	355	535	149	
CM 65	CM 65-125 B1	65	80	100	160	180	125	95	280	212	65	14	14	560	280	340	615	310	460	62
	CM 65-125 B	65	80	100	160	180	125	95	280	212	65	14	14	605	280	340	615	310	460	64
	CM 65-125 A1	65	80	100	160	180	125	95	280	212	65	14	14	560	280	340	615	310	460	68
	CM 65-125 A	65	80	100	160	180	125	95	280	212	65	14	14	605	280	340	615	310	460	70
	CM 65-160 C	65	80	100	160	200	125	95	280	212	65	14	14	635	290	360	665	335	535	84
	CM 65-160 B	65	80	100	160	200	125	95	280	212	65	14	14	635	290	360	665	335	535	90
	CM 65-160 A1	65	80	100	160	200	125	95	280	212	65	14	14	635	290	360	665	355	535	95
	CM 65-160 A	65	80	100	160	200	125	95	280	212	65	14	14	705	290	360	735	355	535	120
	CM 65-200 C1	65	80	100	180	225	125	95	320	250	65	14	14	675	330	405	735	355	535	92
	CM 65-200 C	65	80	100	180	225	125	95	320	250	65	14	14	705	330	405	735	355	535	122
	CM 65-200 B	65	80	100	180	225	125	95	320	250	65	14	14	750	330	405	815	355	535	138
	CM 65-200 A	65	80	100	180	225	125	95	320	250	65	14	14	750	330	405	815	355	535	148
CM 65-250 B	65	80	100	200	250	160	120	360	280	80	16	19	850	370	450	850	380	490	239	
CM 65-250 A	65	80	100	200	250	160	120	360	280	80	16	19	850	370	450	850	380	490	253	
CM 80	CM 80-160 E	80	100	125	180	225	125	95	320	250	65	14	14	665	330	405	665	335	535	92
	CM 80-160 D	80	100	125	180	225	125	95	320	250	65	14	14	665	330	405	665	335	535	98.5
	CM 80-160 C1	80	100	125	180	225	125	95	320	250	65	14	14	665	330	405	665	335	535	104
	CM 80-160 C	80	100	125	180	225	125	95	320	250	65	14	14	735	330	405	735	355	535	129
	CM 80-160 B	80	100	125	180	225	125	95	320	250	65	14	14	780	330	405	815	355	535	143
	CM 80-160 A	80	100	125	180	225	125	95	320	250	65	14	14	780	330	405	815	355	535	152
	CM 80-200 B	80	100	125	180	250	125	95	345	280	65	16	14	840	355	405	850	380	490	233
	CM 80-200 A	80	100	125	180	250	125	95	345	280	65	16	14	840	355	405	850	380	490	247