

|                      |               |
|----------------------|---------------|
| Napajanje            | 3ph 400V 50Hz |
| R.P.M.               | 2850          |
| Slobodni prolaz (mm) | 50            |
| Izlaz (mm)           | DN 80         |
| Masa (Kg)            | 60            |

| Krivulja N° | Code    | Tip pumpe       | MOTOR                |                     |                       | ATEX code |
|-------------|---------|-----------------|----------------------|---------------------|-----------------------|-----------|
|             |         |                 | Nomin. snaga P2 (kW) | Nomin. struja I (A) | Startna struja Is (A) |           |
| 1           | 7002496 | G209T3V1-M50AA0 | 3,2                  | 6,5                 | 31,8                  | 7002807   |
| 2           | 7009360 | G209T3V2-M50AA0 | 3,2                  | 6,5                 | 31,8                  | 7008930   |

## Dimenzije (mm)

MINIMALNI NIVO POTAPANJA

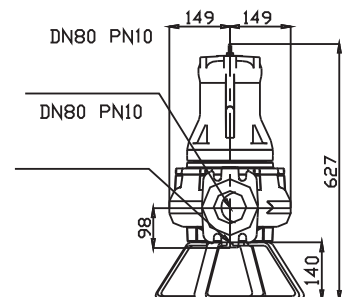
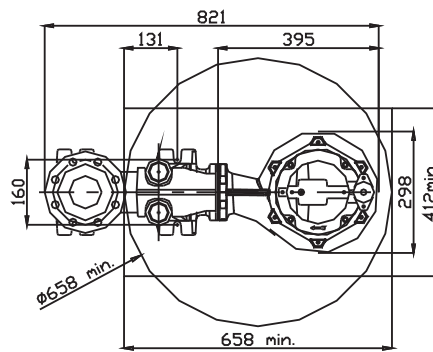
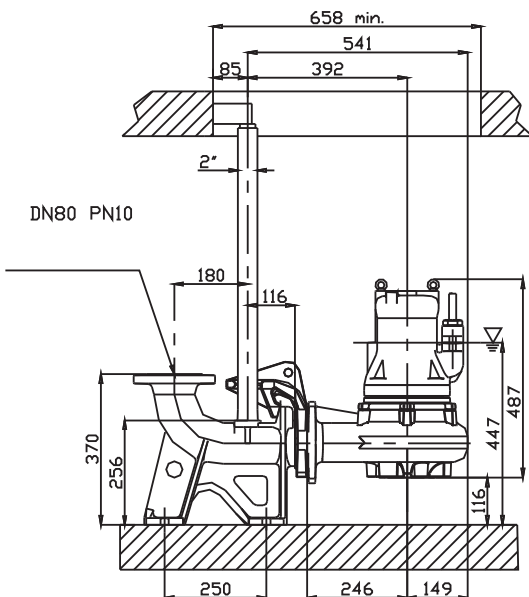

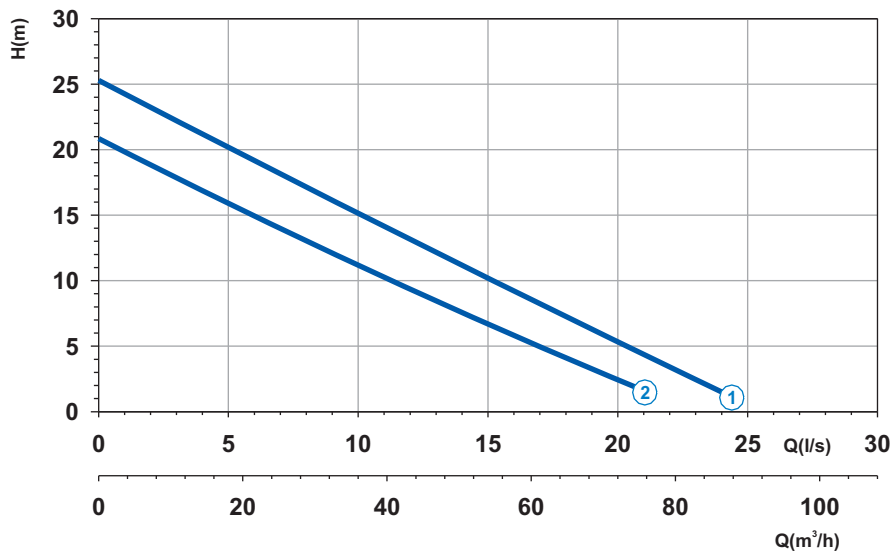

| Krivulja N° | Code    | Tip pumpe       | MOTOR                |                     |                       | ATEX code |
|-------------|---------|-----------------|----------------------|---------------------|-----------------------|-----------|
|             |         |                 | Nomin. snaga P2 (kW) | Nomin. struja I (A) | Startna struja Is (A) |           |
| 1           | 7003212 | G210R3V1-M50AA2 | 5,7                  | 12,5                | 73,7                  | 7002799   |
| 2           | 7003213 | G210R3V2-M50AA2 | 5,0                  | 11                  | 64,9                  | 7002800   |

|                      |                   |
|----------------------|-------------------|
| Napajanje            | 3ph 400/690V 50Hz |
| R.P.M.               | 2850              |
| Slobodni prolaz (mm) | 50                |
| Izlaz (mm)           | DN 80             |
| Masa (Kg)            | 77                |

## Dimenzije (mm)

MINIMALNI NIVO POTAPANJA

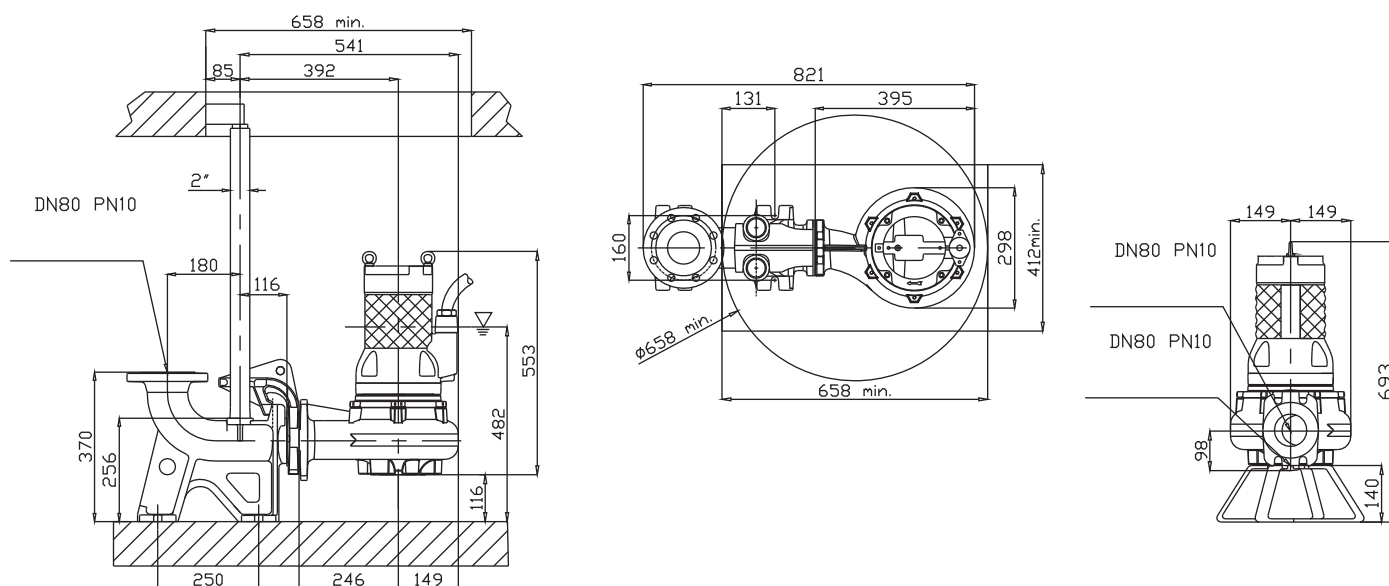

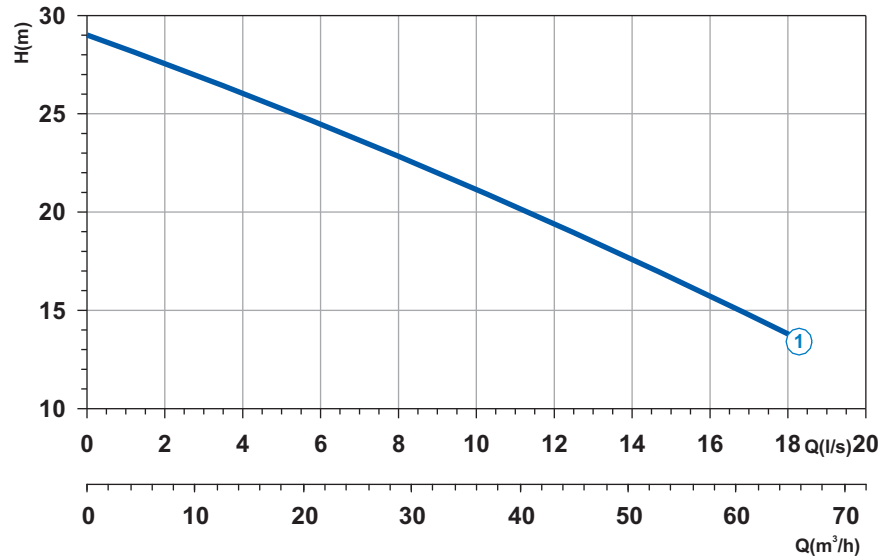

|                      |                   |
|----------------------|-------------------|
| Napajanje            | 3ph 400/690V 50Hz |
| R.P.M.               | 2850              |
| Slobodni prolaz (mm) | 70                |
| Izlaz (mm)           | DN 80             |
| Masa (Kg)            | 160               |

| Krivulja N° | Code    | Tip pumpe       | MOTOR                |                     |                       | ATEX code |
|-------------|---------|-----------------|----------------------|---------------------|-----------------------|-----------|
|             |         |                 | Nomin. snaga P2 (kW) | Nomin. struja I (A) | Startna struja Is (A) |           |
| 1           | 7001683 | G211R3V1-M70AA2 | 7,4                  | 13,8                | 81,4                  | 7008832   |

## Dimenzije (mm)

▽ MINIMALNI NIVO POTAPANJA

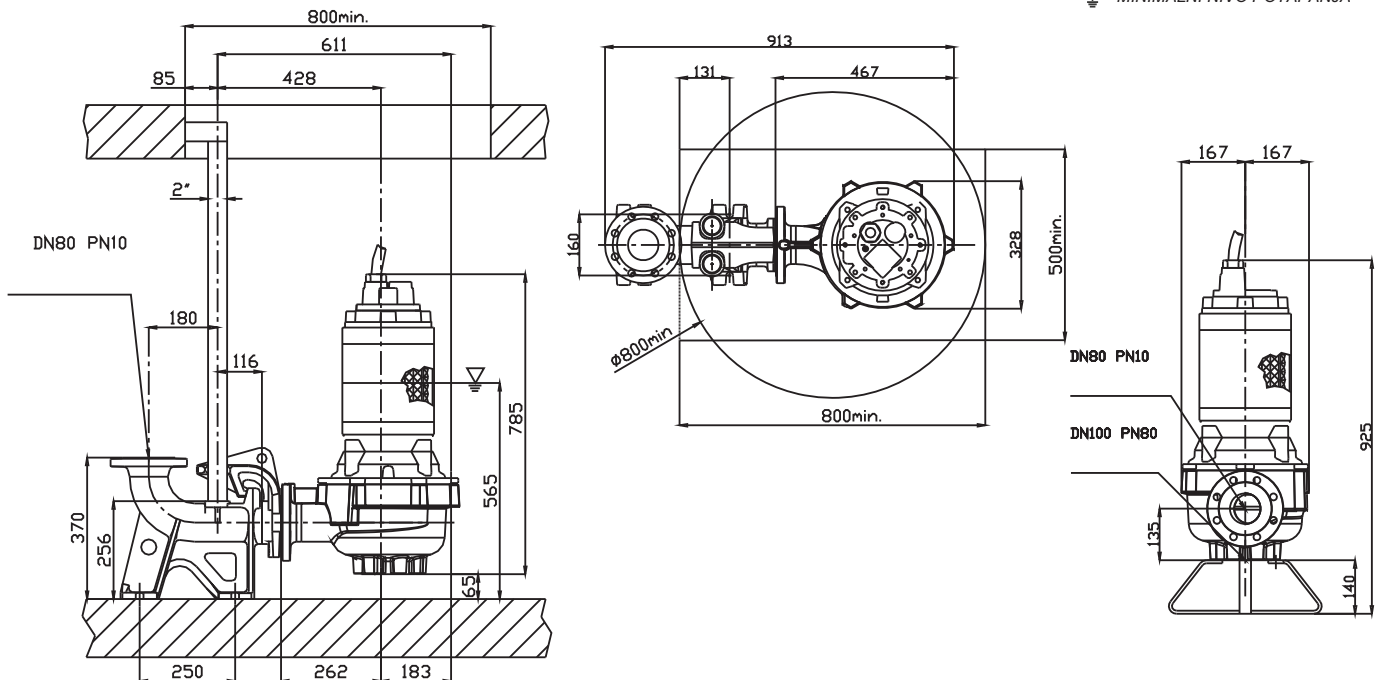

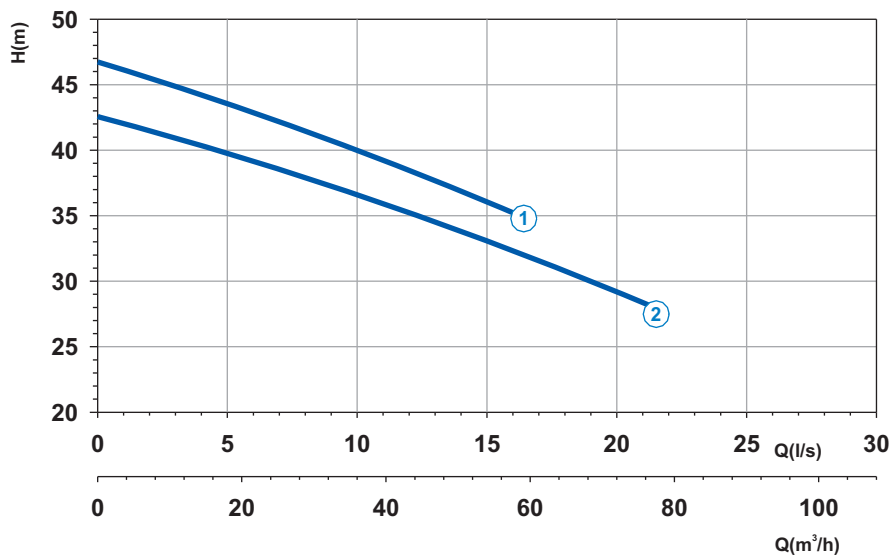

| Krivulja N° | Code    | Tip pumpe       | MOTOR                |                     |                       | ATEX code |
|-------------|---------|-----------------|----------------------|---------------------|-----------------------|-----------|
|             |         |                 | Nomin. snaga P2 (kW) | Nomin. struja I (A) | Startna struja Is (A) |           |
| 1           | 7006428 | G213R6V1-M50AA2 | 18,2                 | 34                  | 193,8                 | 7007469   |
| 2           | 7006429 | G213R6V2-M50AA2 | 18,2                 | 34                  | 193,8                 | 7007398   |

|                      |                   |
|----------------------|-------------------|
| Napajanje            | 3ph 400/690V 50Hz |
| R.P.M.               | 2850              |
| Slobodni prolaz (mm) | 50                |
| Izlaz (mm)           | DN 80             |
| Masa (Kg)            | 191               |

### Dimenzije (mm)

MINIMALNI NIVO POTAPANJA

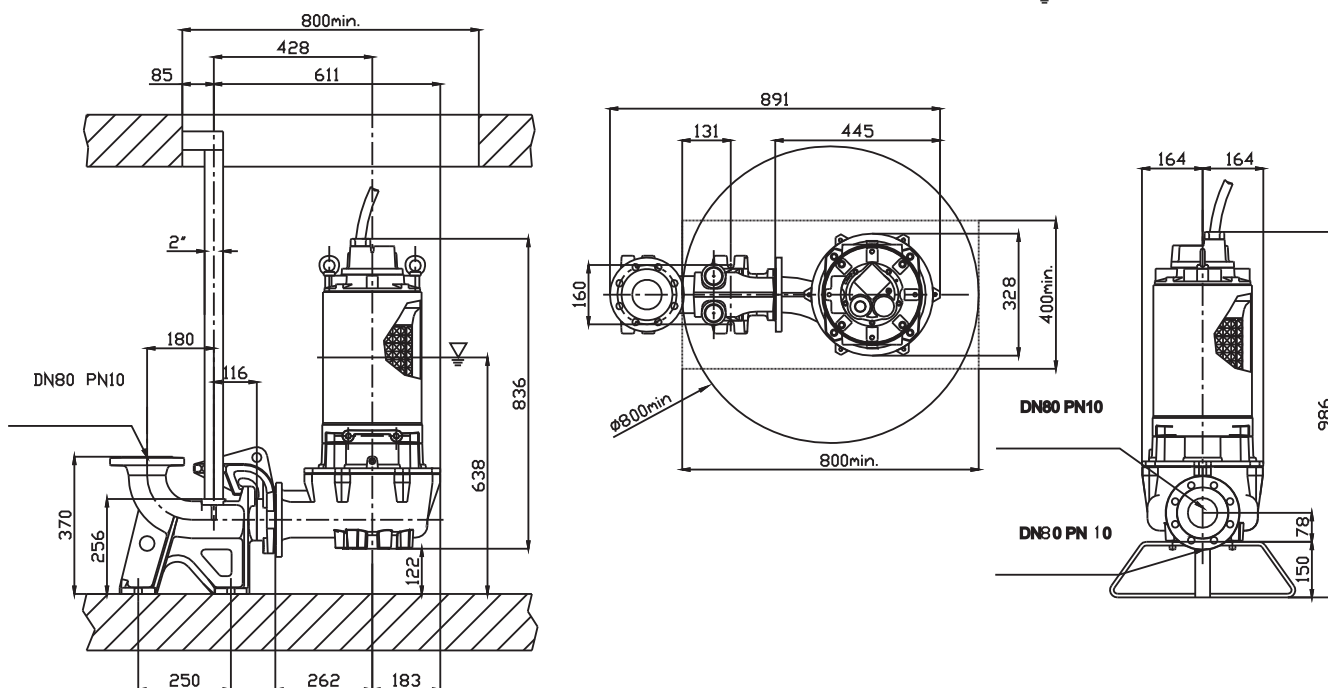

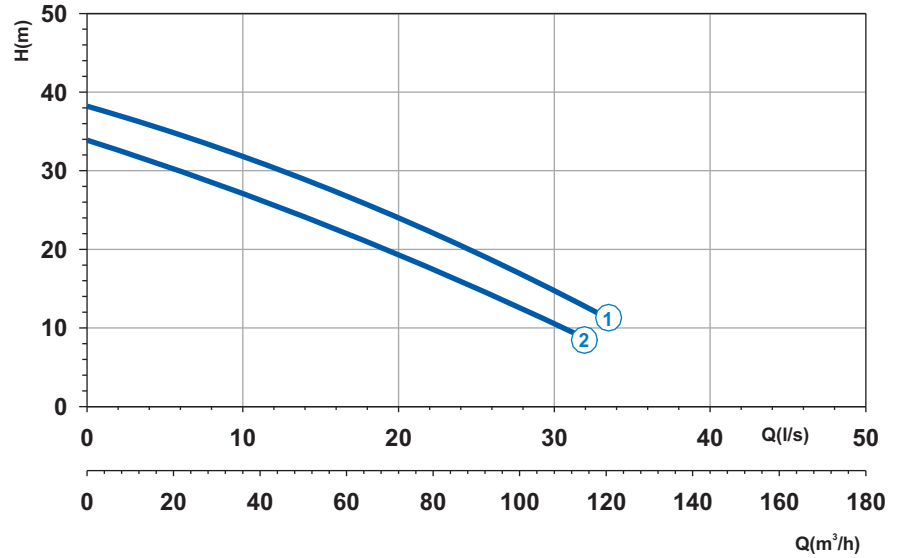

|                      |                   |
|----------------------|-------------------|
| Napajanje            | 3ph 400/690V 50Hz |
| R.P.M.               | 2850              |
| Slobodni prolaz (mm) | 80                |
| Izlaz (mm)           | DN 80             |
| Masa (Kg)            | 190               |

| Krivulja N° | Code    | Tip pumpe       | MOTOR                |                     |                       | ATEX code |
|-------------|---------|-----------------|----------------------|---------------------|-----------------------|-----------|
|             |         |                 | Nomin. snaga P2 (kW) | Nomin. struja I (A) | Startna struja Is (A) |           |
| 1           | 7006110 | G213R3V4-M80AA2 | 18,2                 | 34                  | 193,8                 | 7007473   |
| 2           | 7006112 | G213R3V5-M80AA2 | 15,9                 | 30                  | 171                   | 7007472   |

## Dimenzije (mm)

▽ MINIMALNI NIVO POTAPANJA

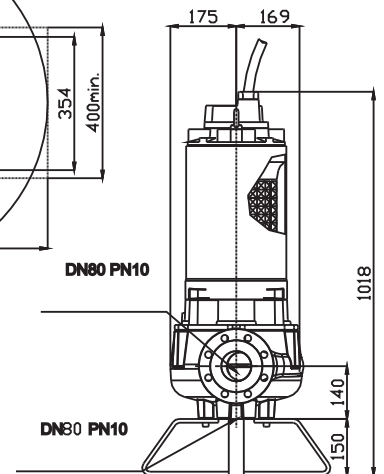
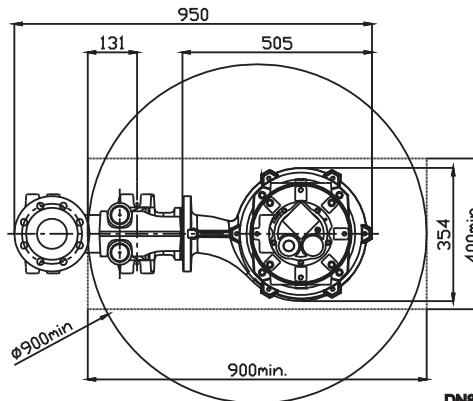
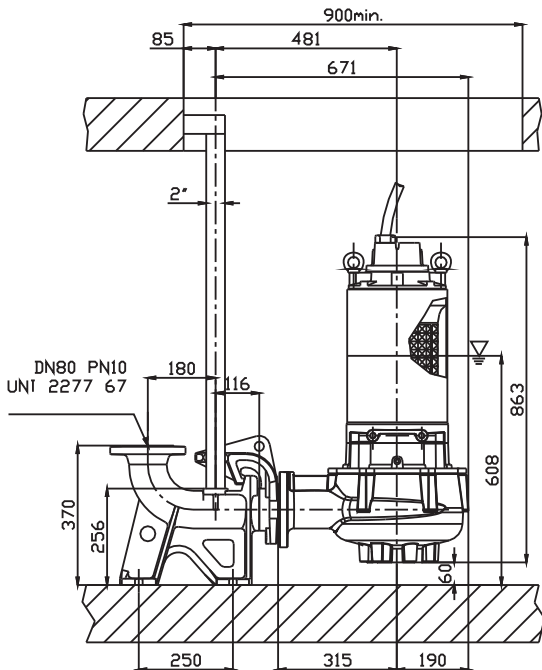

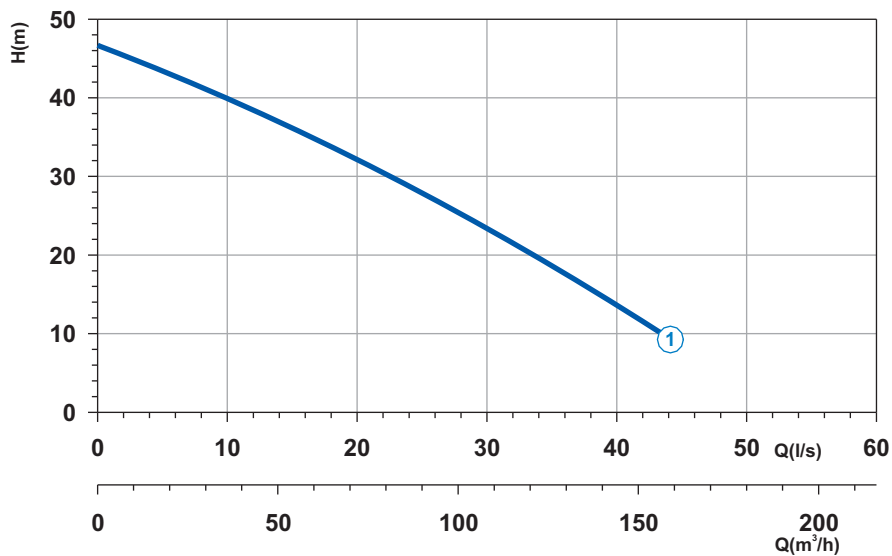

| Krivulja N° | Code    | Tip pumpe       | MOTOR                |                     |                       | ATEX code |  |
|-------------|---------|-----------------|----------------------|---------------------|-----------------------|-----------|--|
|             |         |                 | Nomin. snaga P2 (kW) | Nomin. struja I (A) | Startna struja Is (A) |           |  |
| 1           | 7006850 | G216R3V1-M80AA2 | 24,8                 | 44                  | 260                   | -         |  |

|                      |                   |
|----------------------|-------------------|
| Napajanje            | 3ph 400/690V 50Hz |
| R.P.M.               | 2850              |
| Slobodni prolaz (mm) | 80                |
| Izlaz (mm)           | DN 80             |
| Masa (Kg)            | 315               |

### Dimenzije (mm)

MINIMALNI NIVO POTAPANJA

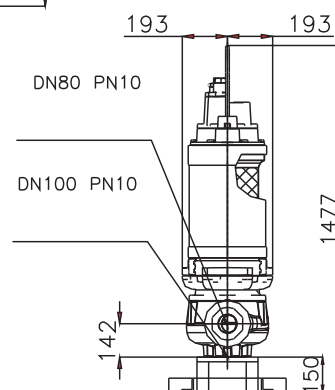
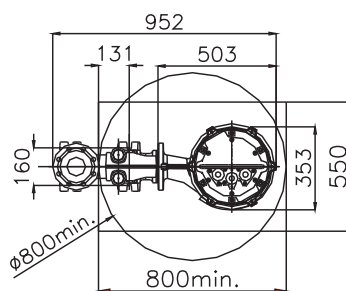
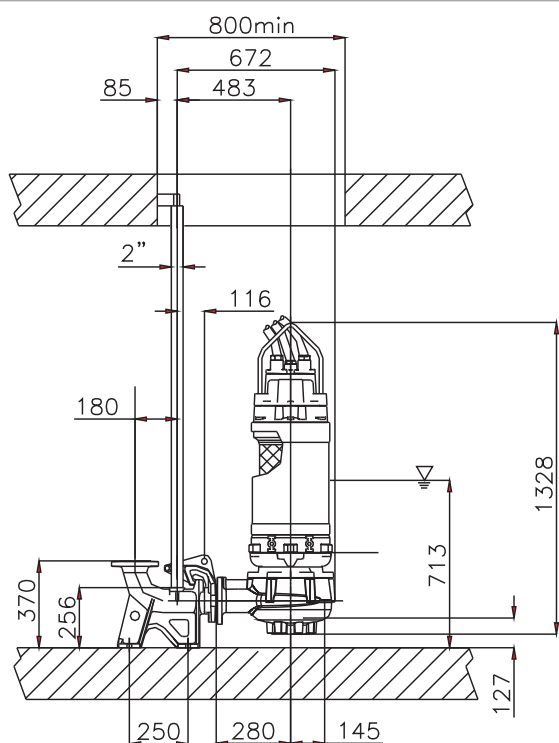

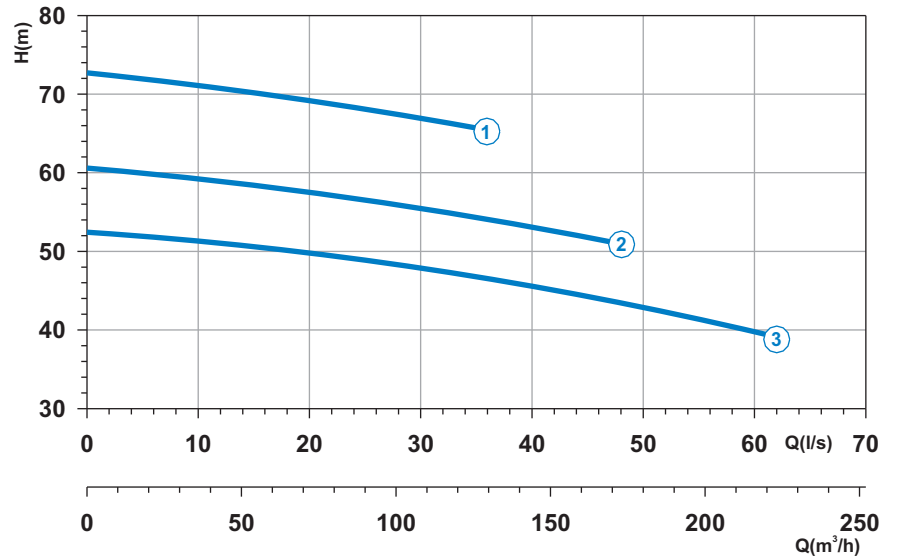

|                      |                   |
|----------------------|-------------------|
| Napajanje            | 3ph 400/690V 50Hz |
| R.P.M.               | 2850              |
| Slobodni prolaz (mm) | 80                |
| Izlaz (mm)           | DN 100            |
| Masa (Kg)            | 400               |

| Krivulja N° | Code    | Tip pumpe       | MOTOR                |                     |                       | ATEX code |
|-------------|---------|-----------------|----------------------|---------------------|-----------------------|-----------|
|             |         |                 | Nomin. snaga P2 (kW) | Nomin. struja I (A) | Startna struja Is (A) |           |
| 1           | 7002380 | G218R9V2-P80AA2 | 48,2                 | 86,5                | 510                   | -         |
| 2           | 7001837 | G218R9V3-P80AA2 | 48,2                 | 86,5                | 510                   | -         |
| 3           | 7002628 | G218R9V4-P80AA2 | 48,2                 | 86,5                | 510                   | -         |

## Dimenzije (mm)

MINIMALNI NIVO POTAPANJA

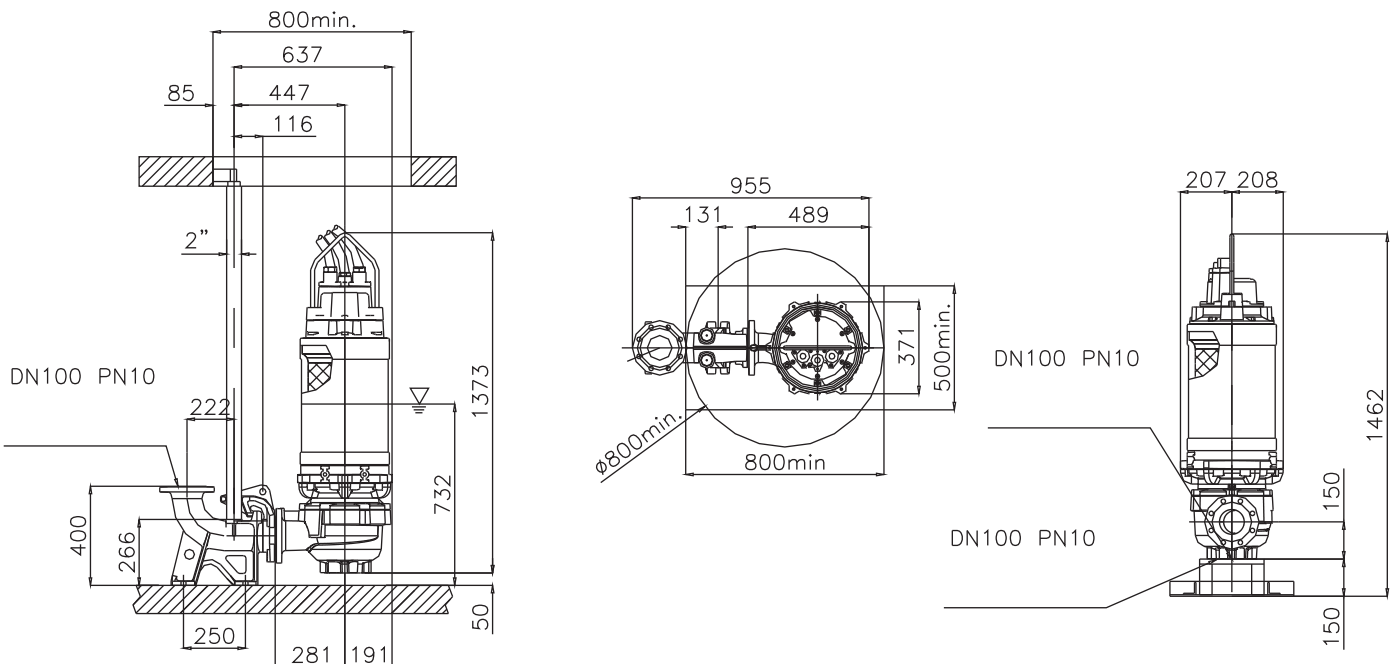

Suha instalacija



G211R3V1-M70AA2

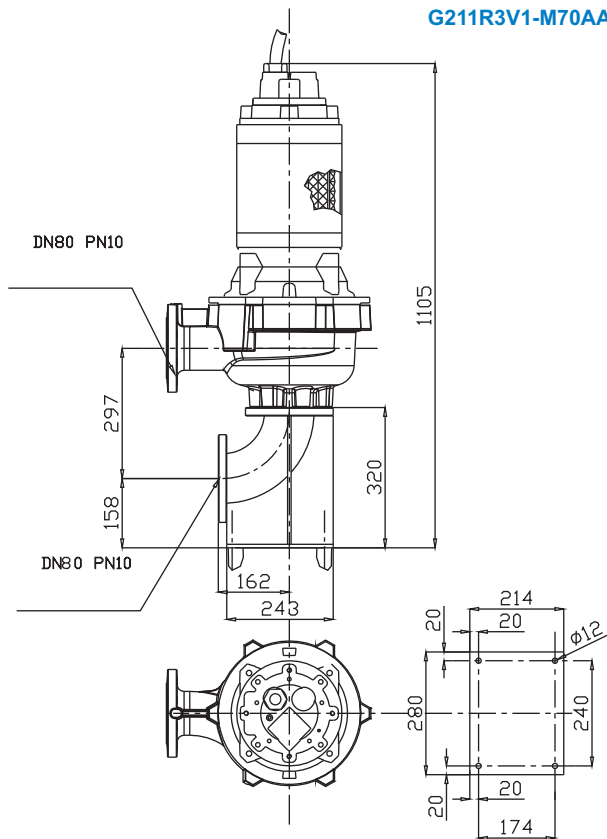

G213R6V1-M50AA2  
G213R6V2-M50AA2  
G213R3V4-M80AA2  
G213R3V5-M80AA2

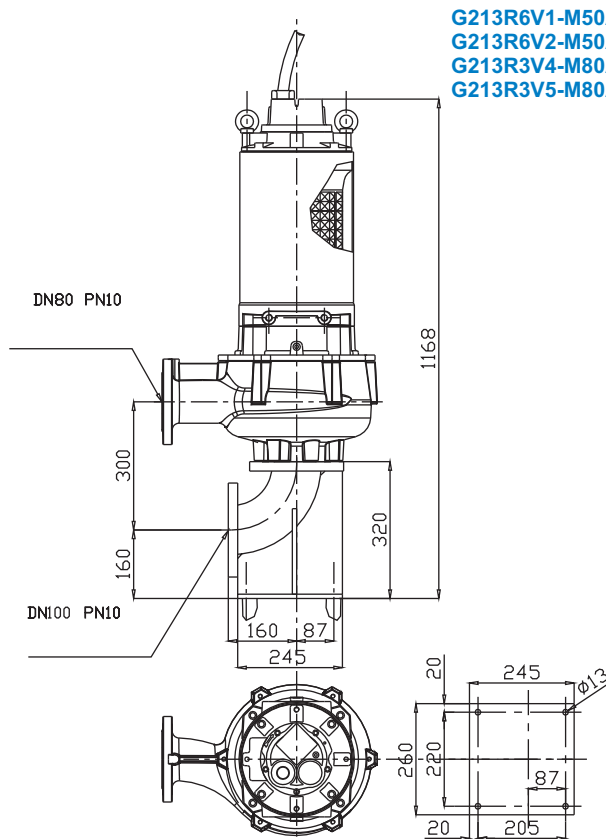

G216R3V1-M80AA2

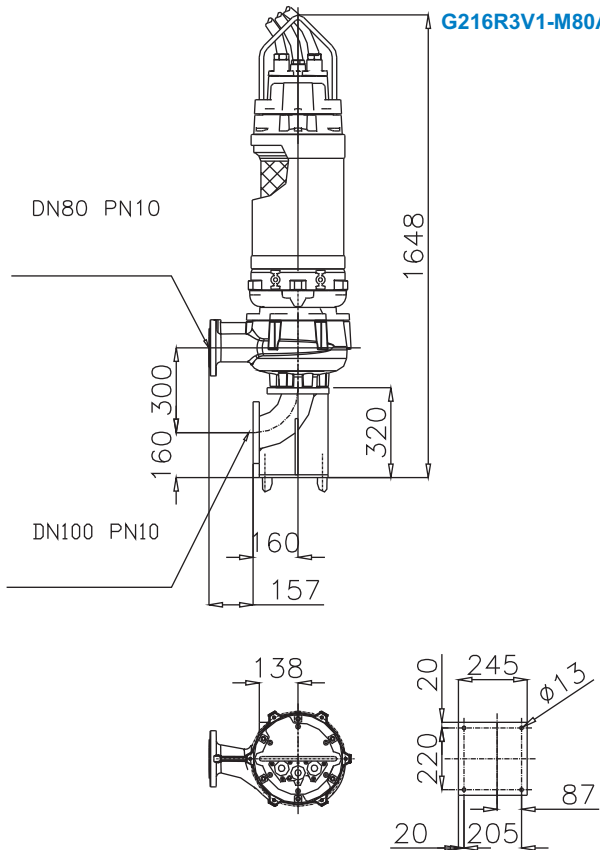

G218R9V2-P80AA2  
G218R9V3-P80AA2  
G218R9V4-P80AA2

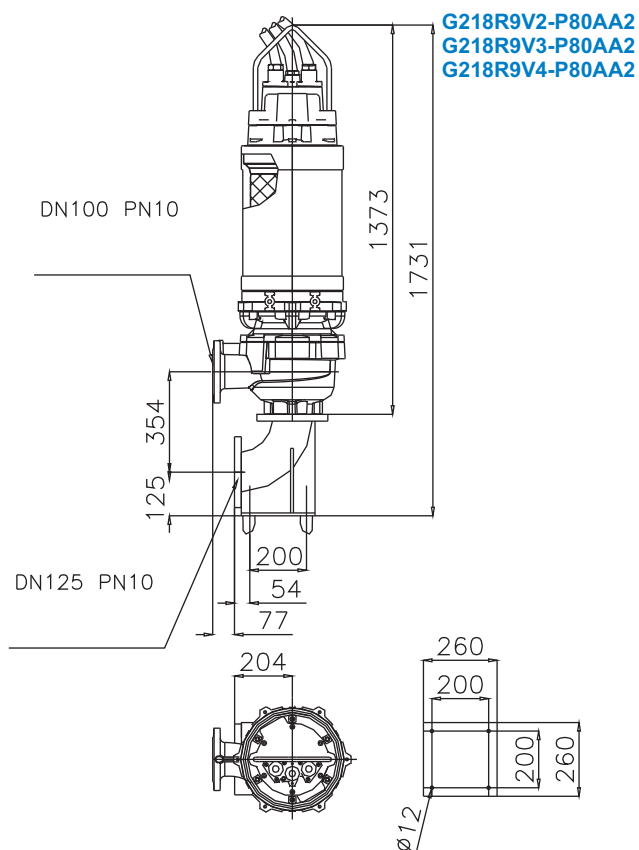

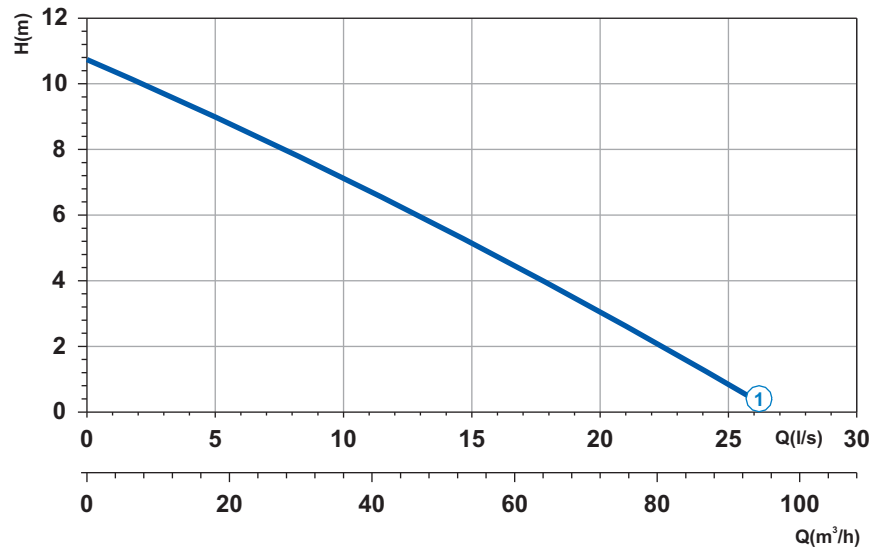

|                      |               |
|----------------------|---------------|
| Napajanje            | 3ph 400V 50Hz |
| R.P.M.               | 1450          |
| Slobodni prolaz (mm) | 60            |
| Izlaz (mm)           | DN 80         |
| Masa (Kg)            | 64            |

| Krivulja N° | Code    | Tip pompe       | MOTOR                |                     |                       | ATEX code |
|-------------|---------|-----------------|----------------------|---------------------|-----------------------|-----------|
|             |         |                 | Nomin. snaga P2 (kW) | Nomin. struja I (A) | Startna struja Is (A) |           |
| 1           | 7007382 | G409T6V1-M60AA0 | 2,8                  | 6,5                 | 29,2                  | 7007625   |

## Dimenzije (mm)

▽ MINIMALNI NIVO POTAPANJA

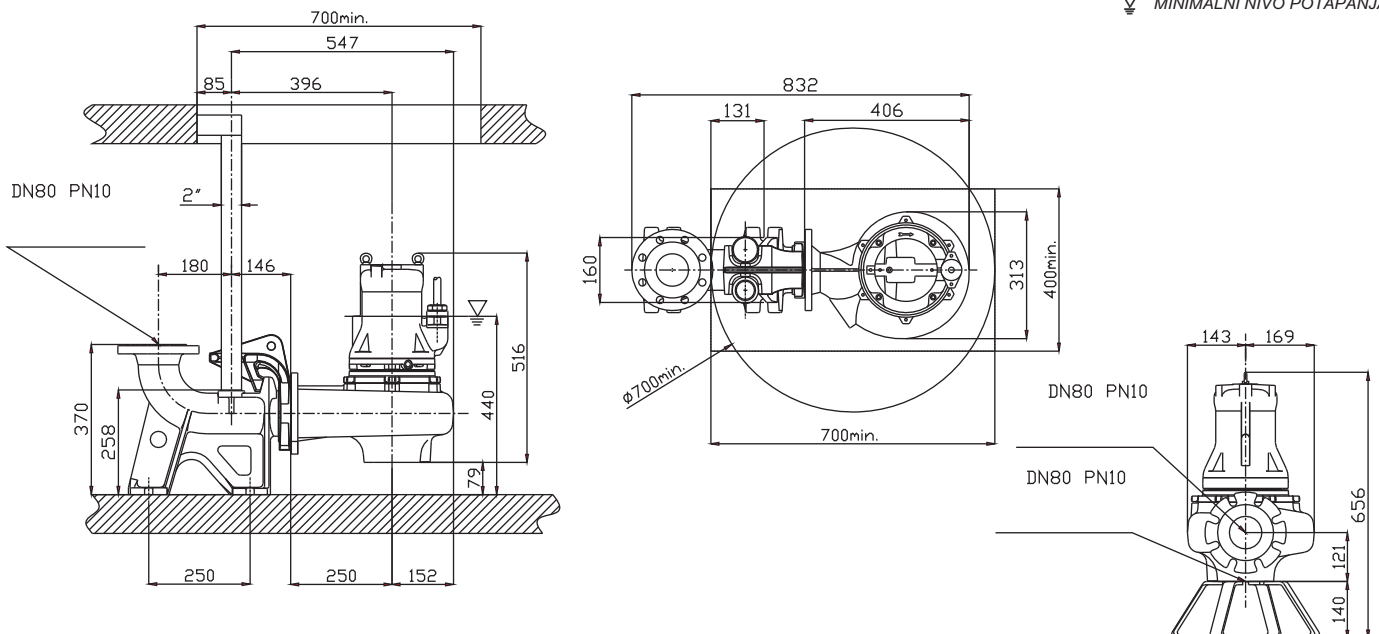

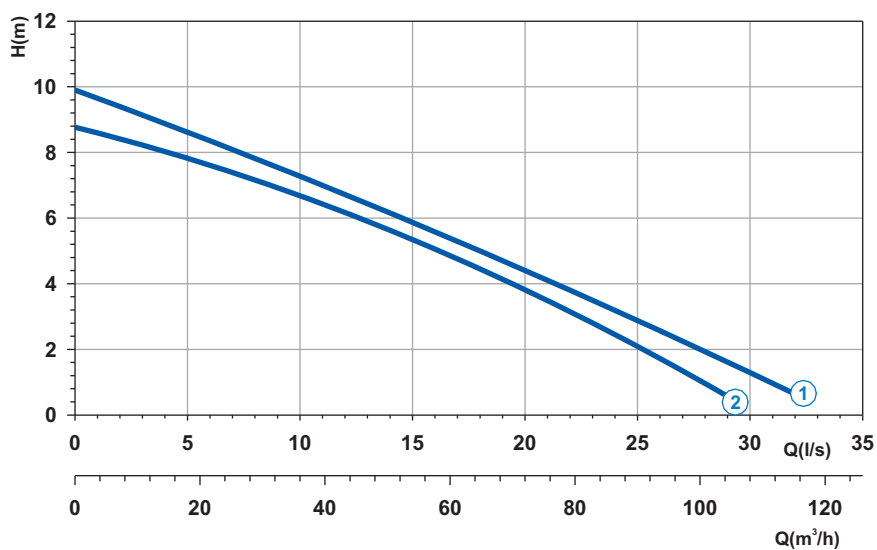

| Krivulja N° | Code    | Tip pumpe       | MOTOR                |                     |                       | ATEX code |
|-------------|---------|-----------------|----------------------|---------------------|-----------------------|-----------|
|             |         |                 | Nomin. snaga P2 (kW) | Nomin. struja I (A) | Startna struja Is (A) |           |
| 1           | 7002013 | G409T6V1-M64AA0 | 2,8                  | 6,5                 | 29,2                  | 7002794   |
| 2           | 7002018 | G409T6V2-M64AA0 | 2,8                  | 6,5                 | 29,2                  | 7002796   |

|                      |               |
|----------------------|---------------|
| Napajanje            | 3ph 400V 50Hz |
| R.P.M.               | 1450          |
| Slobodni prolaz (mm) | 64            |
| Izlaz (mm)           | DN 80         |
| Masa (Kg)            | 64            |

## Dimenzije (mm)

MINIMALNI NIVO POTAPANJA

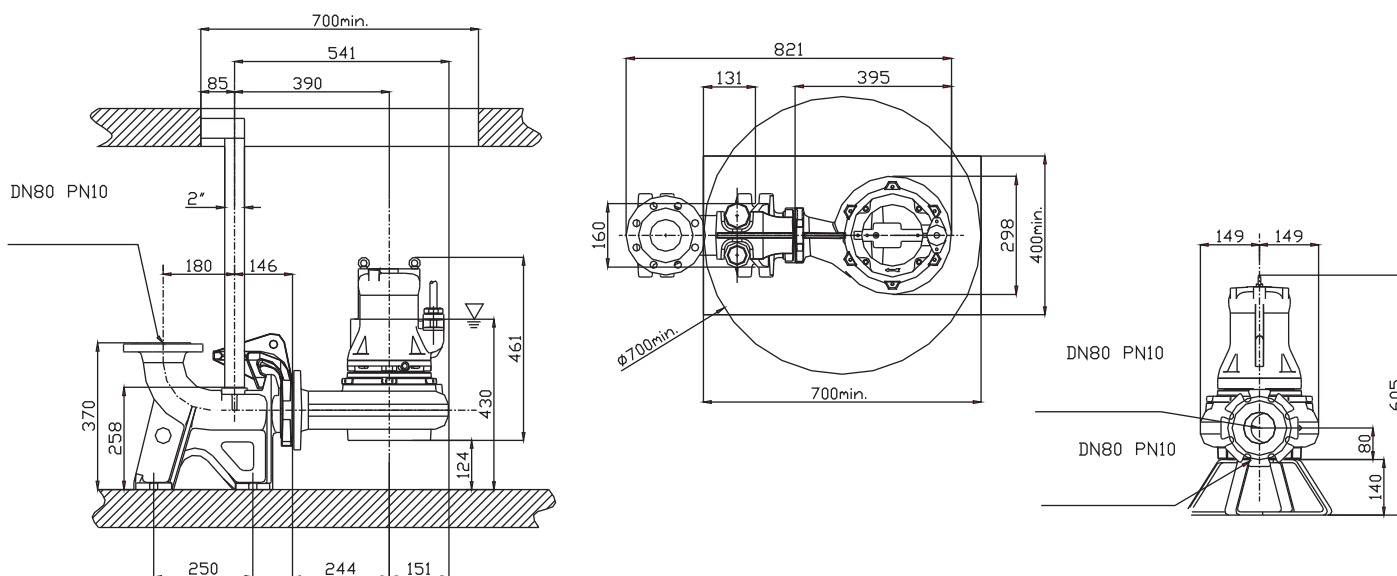

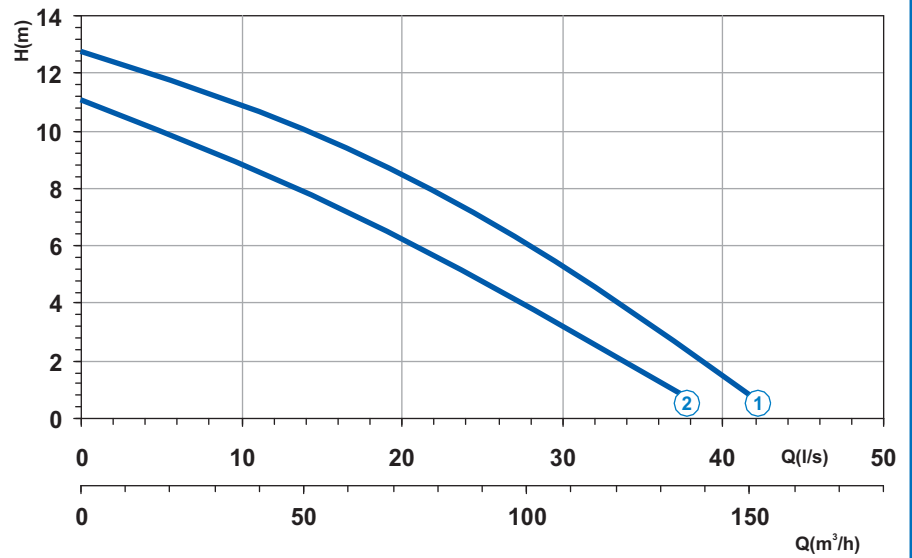

|                      |                   |
|----------------------|-------------------|
| Napajanje            | 3ph 400/690V 50Hz |
| R.P.M.               | 1450              |
| Slobodni prolaz (mm) | 64                |
| Izlaz (mm)           | DN 80             |
| Masa (Kg)            | 79                |

| Krivulja N° | Code    | Tip pumpe              | MOTOR                |                     |                       | ATEX code  |
|-------------|---------|------------------------|----------------------|---------------------|-----------------------|---|
|             |         |                        | Nomin. snaga P2 (kW) | Nomin. struja I (A) | Startna struja Is (A) |   |
| 1           | 7002016 | <b>G410R6V1-M64AA2</b> | 4,6                  | 9,5                 | 42,7                  | 7008203   |
| 2           | 7007908 | <b>G410R6V2-M64AA2</b> | 3,8                  | 8                   | 36                    | 7002765   |

## Dimenzije (mm)

▽ MINIMALNI NIVO POTAPANJA

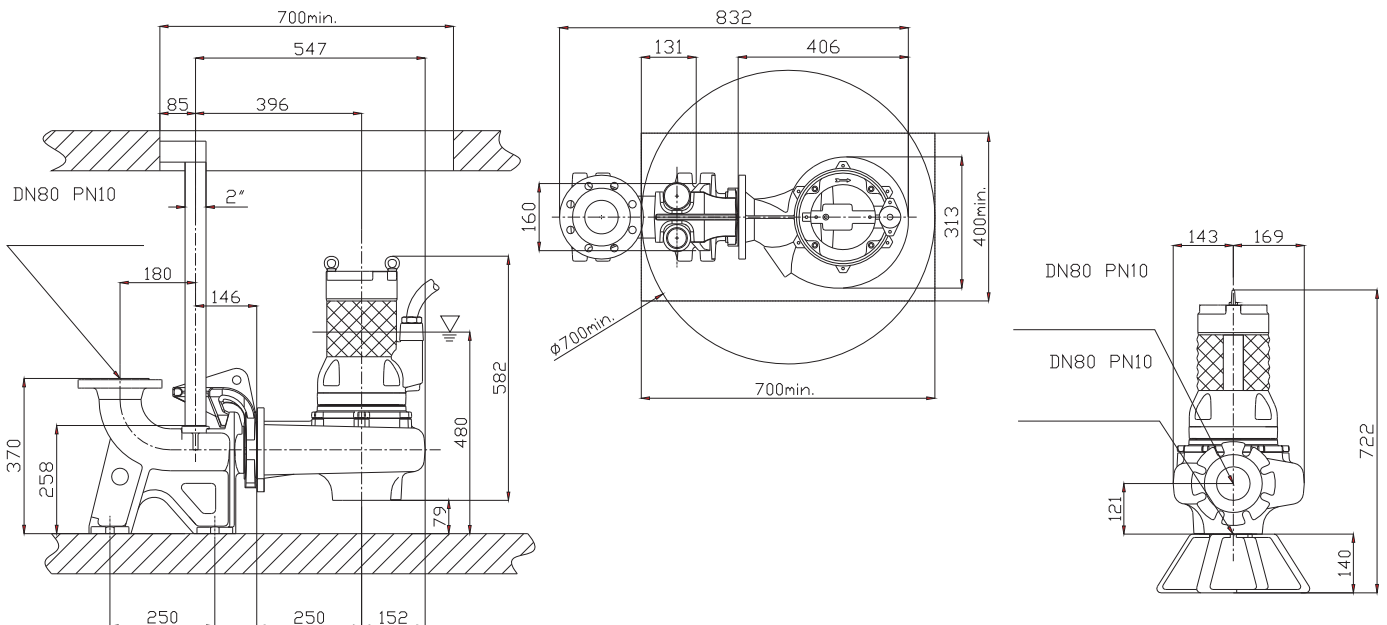

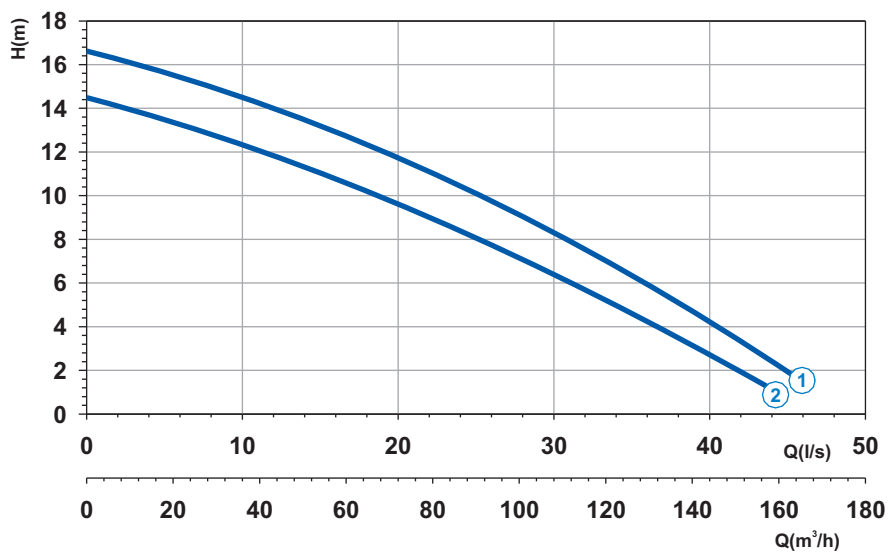

| Krivulja N° | Code    | Tip pumpe       | MOTOR                |                     |                       | ATEX code |
|-------------|---------|-----------------|----------------------|---------------------|-----------------------|-----------|
|             |         |                 | Nomin. snaga P2 (kW) | Nomin. struja I (A) | Startna struja Is (A) |           |
| 1           | 7006377 | G411R6V1-P90AA2 | 7,1                  | 13,5                | 64,8                  | 7007500   |
| 2           | 7006378 | G411R6V2-P90AA2 | 7,1                  | 13,5                | 64,8                  | 7007501   |

|                      |                   |
|----------------------|-------------------|
| Napajanje            | 3ph 400/690V 50Hz |
| R.P.M.               | 1450              |
| Slobodni prolaz (mm) | 90                |
| Izlaz (mm)           | DN 100            |
| Masa (Kg)            | 160               |

## Dimenzije (mm)

MINIMALNI NIVO POTAPANJA

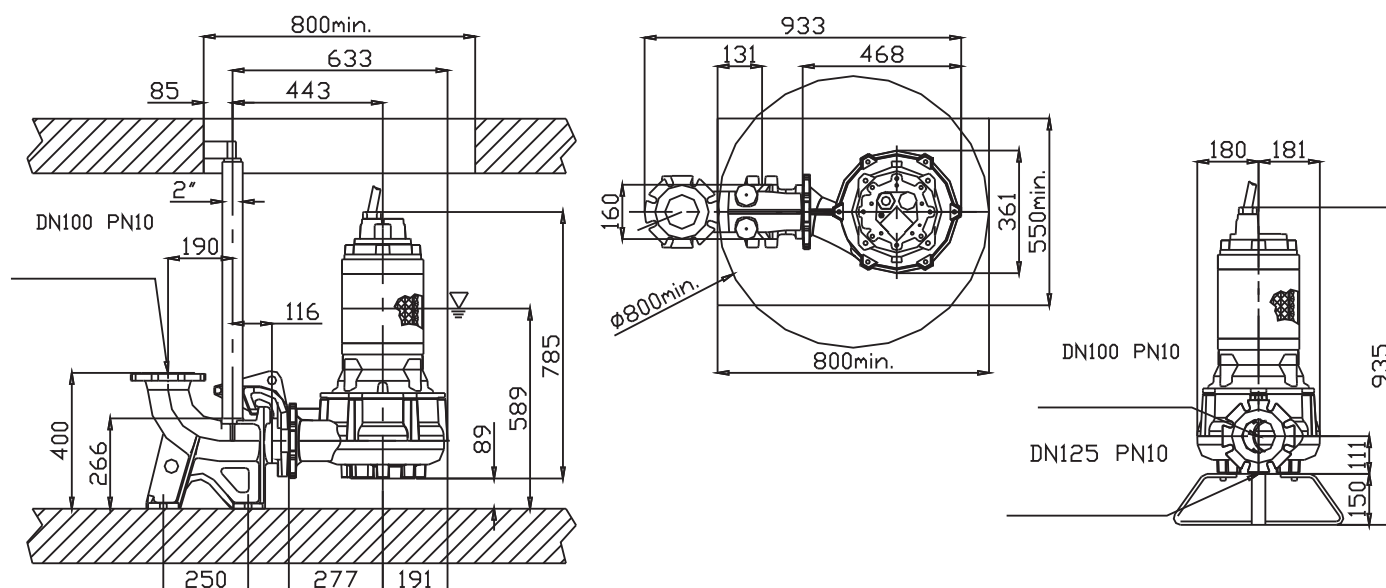

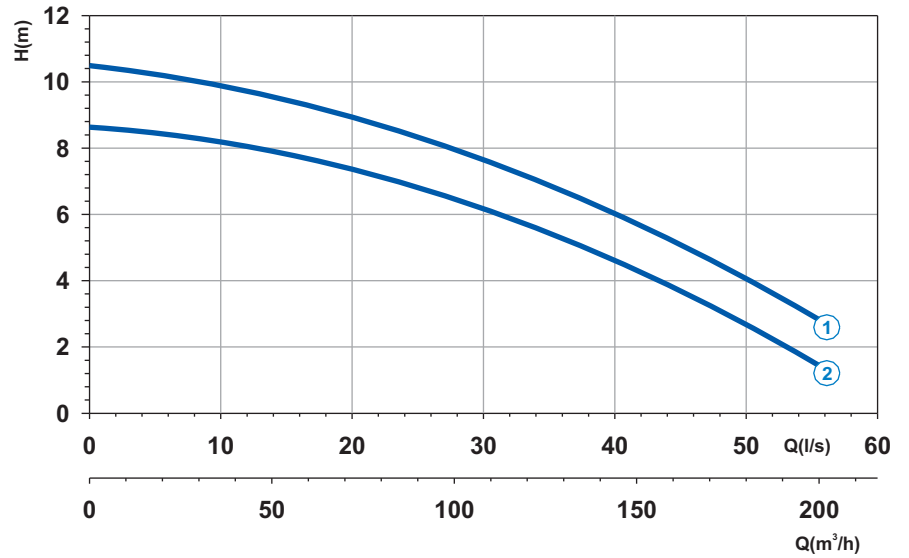

|                      |                   |
|----------------------|-------------------|
| Napajanje            | 3ph 400/690V 50Hz |
| R.P.M.               | 950               |
| Slobodni prolaz (mm) | 80                |
| Izlaz (mm)           | DN 100            |
| Masa (Kg)            | 166               |

| Krivulja N° | Code    | Tip pumpe       | MOTOR                |                     |                       | ATEX code |
|-------------|---------|-----------------|----------------------|---------------------|-----------------------|-----------|
|             |         |                 | Nomin. snaga P2 (kW) | Nomin. struja I (A) | Startna struja Is (A) |           |
| 1           | 7002253 | G611R6V1-P80AA2 | 5,2                  | 12,5                | 63,7                  | 7007504   |
| 2           | 7004980 | G611R6V2-P80AA2 | 5,2                  | 12,5                | 63,7                  | 7007503   |

## Dimenzije (mm)

▽ MINIMALNI NIVO POTAPANJA

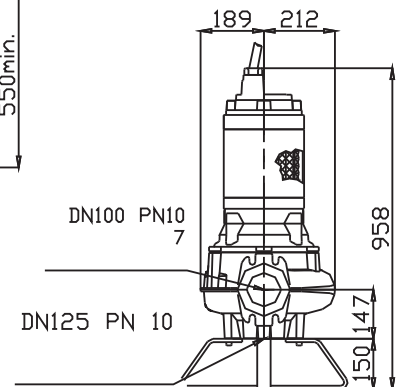
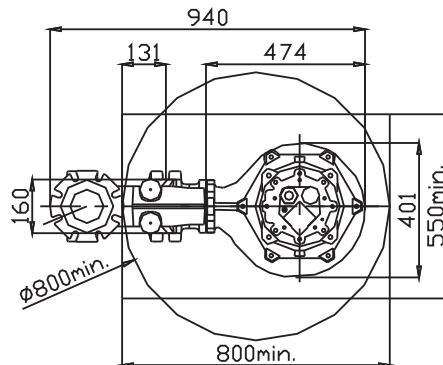
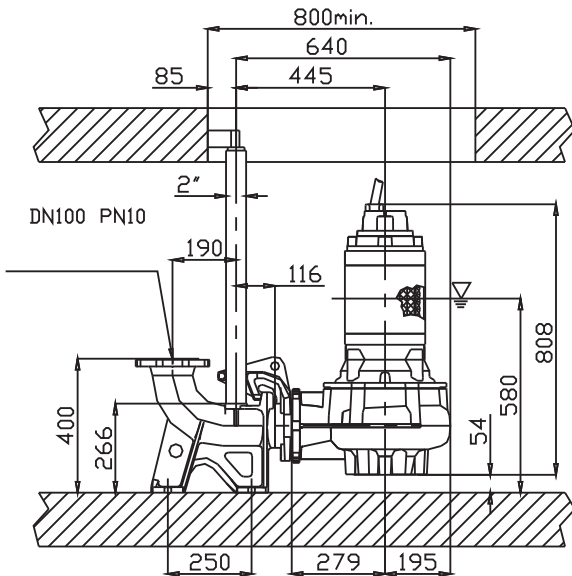



V

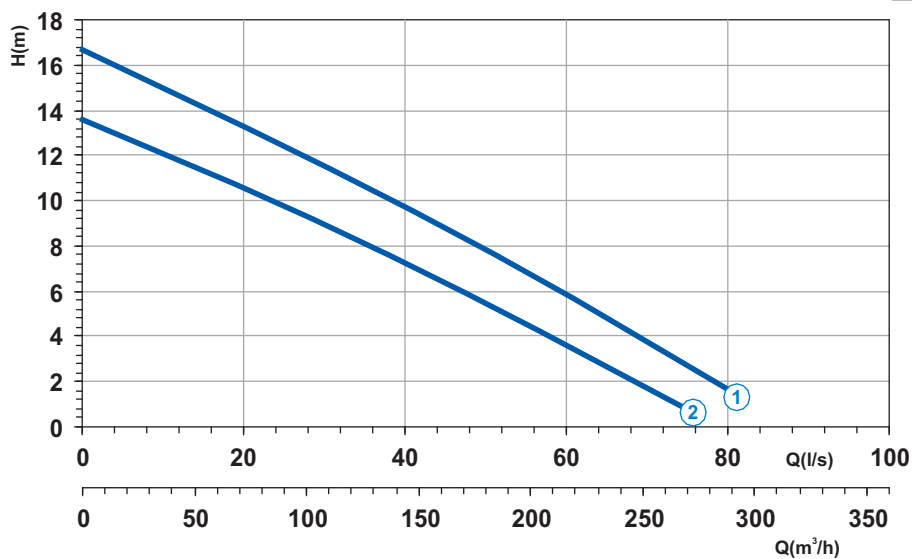

| Krivulja N° | Code    | Tip pumpe        | MOTOR                |                     |                       | ATEX code |  |
|-------------|---------|------------------|----------------------|---------------------|-----------------------|-----------|--|
|             |         |                  | Nomin. snaga P2 (kW) | Nomin. struja I (A) | Startna struja Is (A) |           |  |
| 1           | 7000299 | G618R3V1-S100AA2 | 13,6                 | 27,5                | 148,5                 | -         |  |
| 2           | 7000300 | G618R3V2-S100AA2 | 11,0                 | 23,0                | 124,2                 | -         |  |

|                      |                   |
|----------------------|-------------------|
| Napajanje            | 3ph 400/690V 50Hz |
| R.P.M.               | 950               |
| Slobodni prolaz (mm) | 100               |
| Izlaz (mm)           | DN 150            |
| Masa (Kg)            | 361               |

## Dimenzije (mm)

MINIMALNI NIVO POTAPANJA

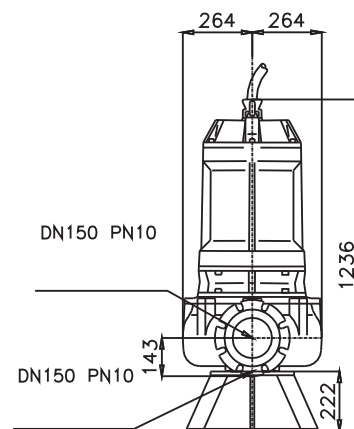
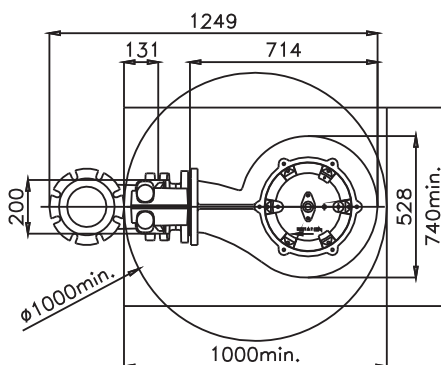
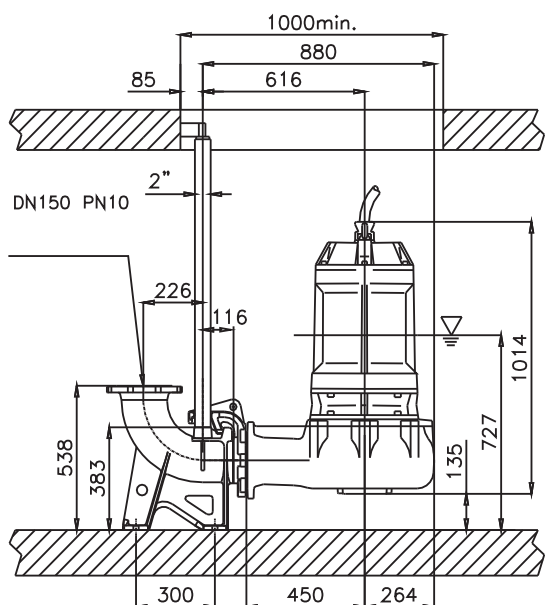

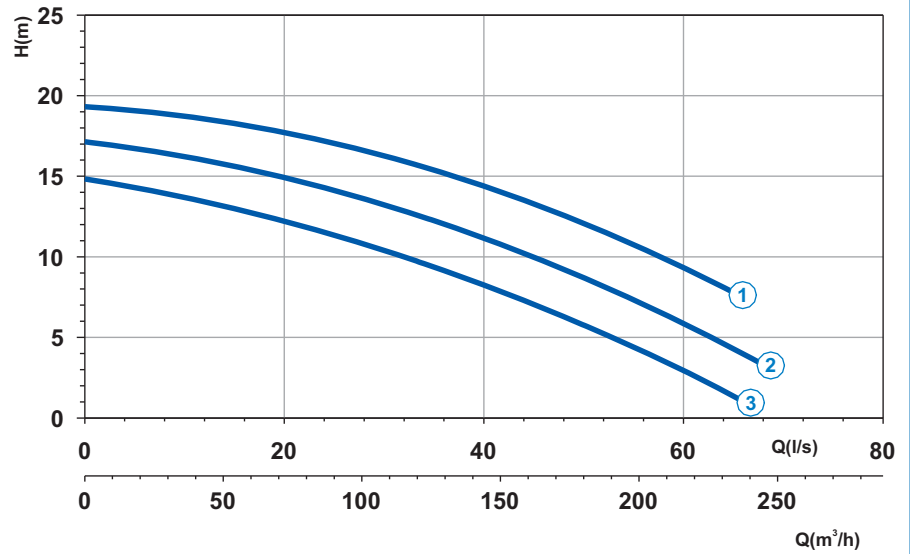

|                      |                   |
|----------------------|-------------------|
| Napajanje            | 3ph 400/690V 50Hz |
| R.P.M.               | 1450              |
| Slobodni prolaz (mm) | 80                |
| Izlaz (mm)           | DN 100            |
| Masa (Kg)            | 200               |

| Krivulja N° | Code    | Tip pompe              | MOTOR                |                     |                       | ATEX code |
|-------------|---------|------------------------|----------------------|---------------------|-----------------------|-----------|
|             |         |                        | Nomin. snaga P2 (kW) | Nomin. struja I (A) | Startna struja Is (A) |           |
| 1           | 7000189 | <b>G413R6V1-P80AA2</b> | 14,1                 | 30                  | 165                   | 7007474   |
| 2           | 7001145 | <b>G413R6V2-P80AA2</b> | 14,1                 | 30                  | 165                   | 7007390   |
| 3           | 7001166 | <b>G413R6V3-P80AA2</b> | 10,1                 | 22                  | 121                   | 7007487   |

## Dimenzije (mm)

▽ MINIMALNI NIVO POTAPANJA

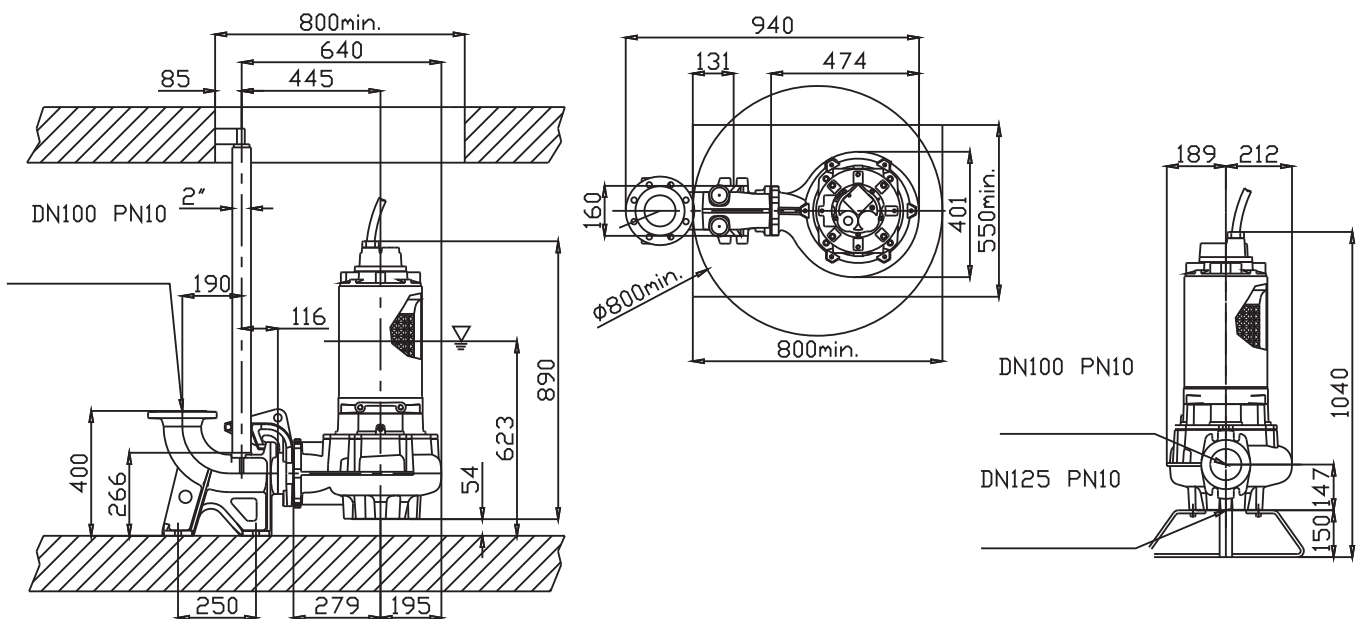

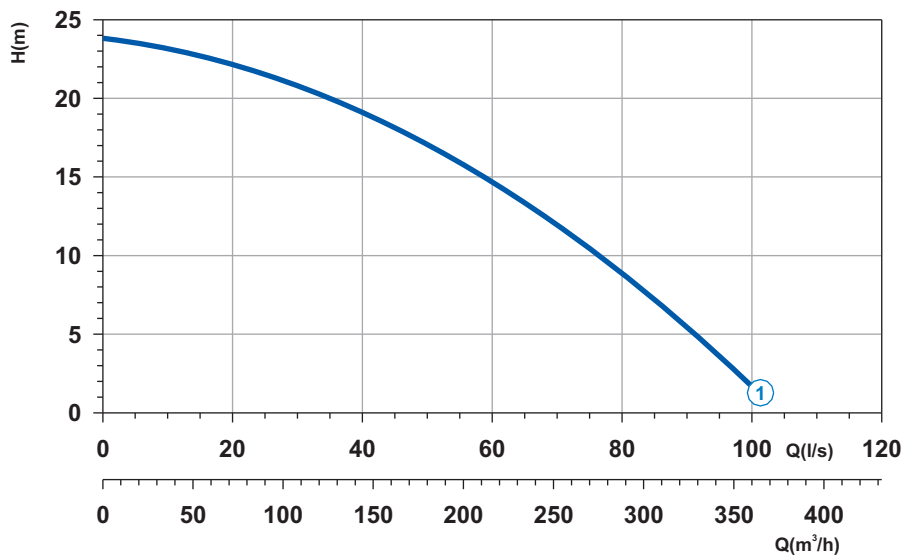

| Krivulja N° | Code    | Tip pumpe       | MOTOR                |                     |                       | ATEX code |
|-------------|---------|-----------------|----------------------|---------------------|-----------------------|-----------|
|             |         |                 | Nomin. snaga P2 (kW) | Nomin. struja I (A) | Startna struja Is (A) |           |
| 1           | 7006001 | G416R6V1-P80AA2 | 25,4                 | 48,5                | 286                   | -         |

|                      |                   |
|----------------------|-------------------|
| Napajanje            | 3ph 400/690V 50Hz |
| R.P.M.               | 1450              |
| Slobodni prolaz (mm) | 80                |
| Izlaz (mm)           | DN 100            |
| Masa (Kg)            | 280               |

### Dimenzije (mm)

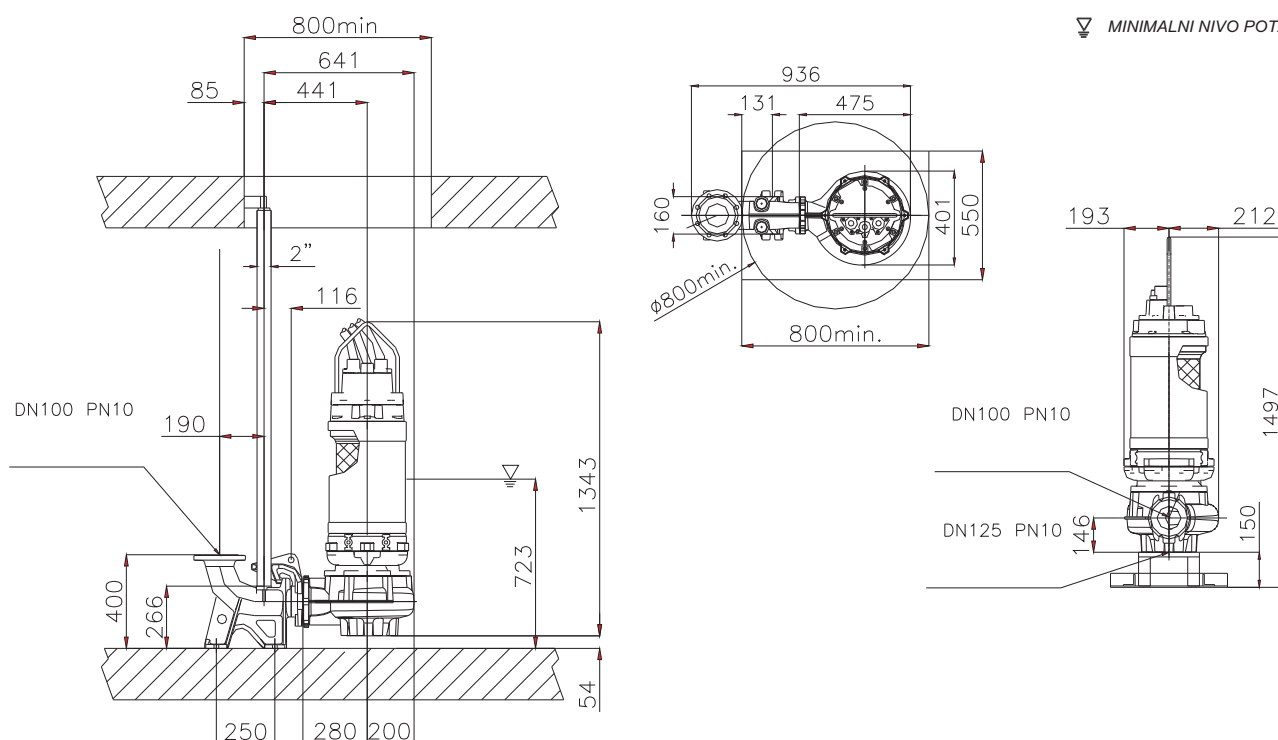

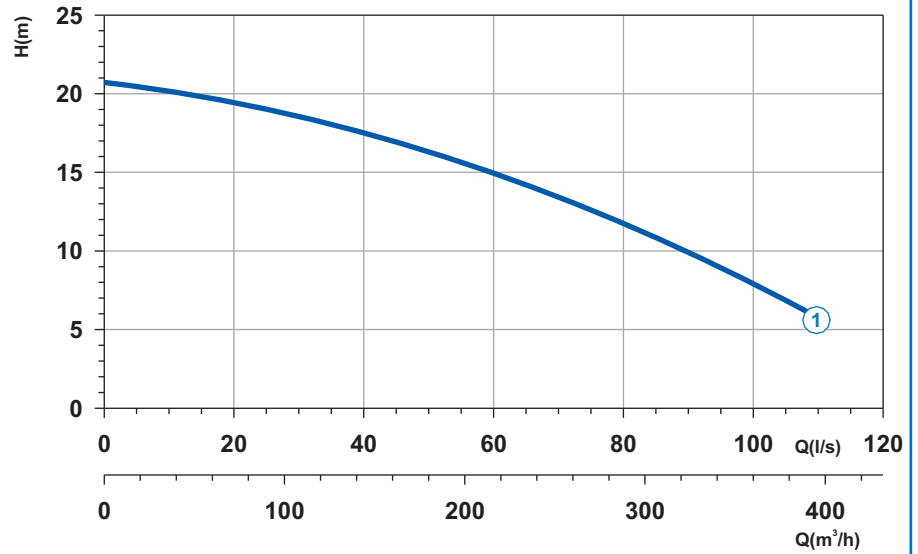

|                      |                   |
|----------------------|-------------------|
| Napajanje            | 3ph 400/690V 50Hz |
| R.P.M.               | 1450              |
| Slobodni prolaz (mm) | 100               |
| Izlaz (mm)           | DN 150            |
| Masa (Kg)            | 290               |

| Krivulja N° | Code    | Tip pumpe        | MOTOR                |                     |                       | ATEX code |
|-------------|---------|------------------|----------------------|---------------------|-----------------------|-----------|
|             |         |                  | Nomin. snaga P2 (kW) | Nomin. struja I (A) | Startna struja Is (A) |           |
| 1           | 7005168 | G416R6V1-S100AA2 | 25,4                 | 48,5                | 286                   | -         |

## Dimenzije (mm)

▽ MINIMALNI NIVO POTAPANJA

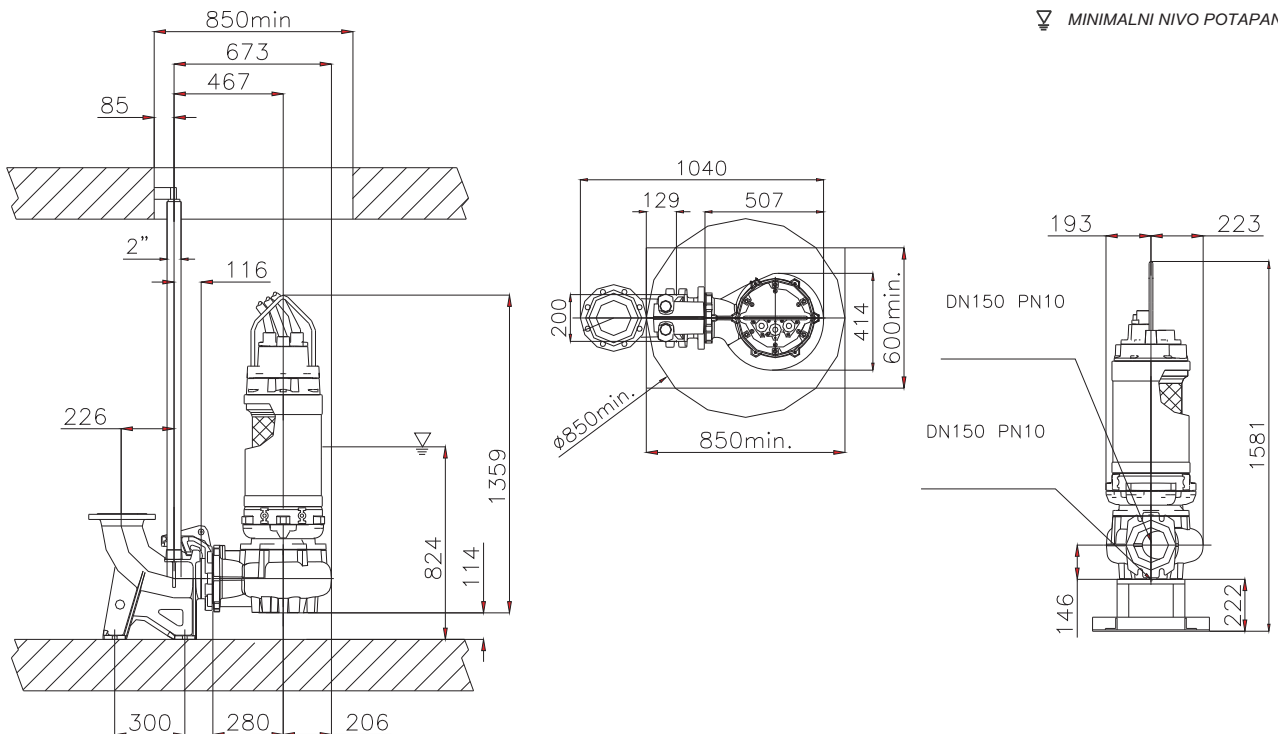

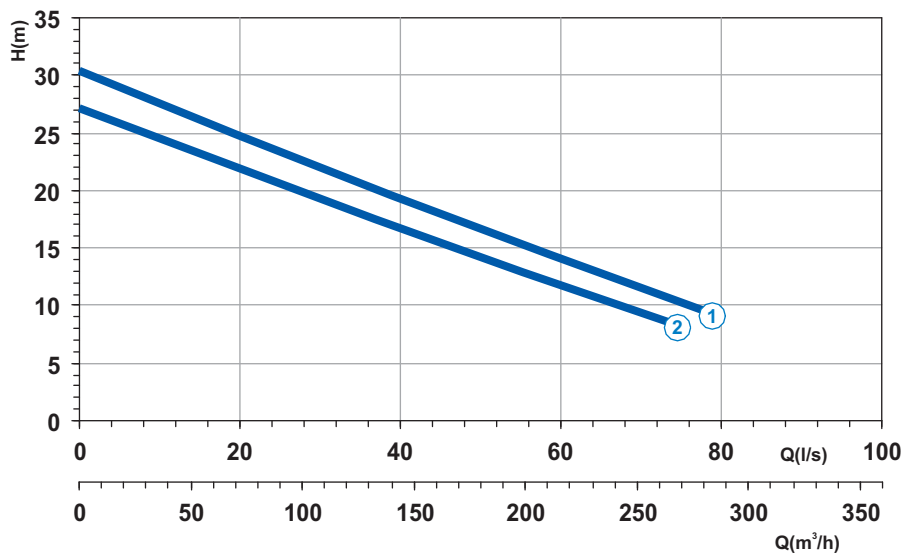

| Krivulja N° | Code    | Tip pumpe        | MOTOR                |                     |                       | ATEX code |
|-------------|---------|------------------|----------------------|---------------------|-----------------------|-----------|
|             |         |                  | Nomin. snaga P2 (kW) | Nomin. struja I (A) | Startna struja Is (A) |           |
| 1           | 7000295 | G418R3V2-S100AA2 | 35,7                 | 65,5                | 386,4                 | -         |
| 2           | 7000296 | G418R3V3-S100AA2 | 25                   | 48                  | 283,2                 | -         |

|                      |                   |
|----------------------|-------------------|
| Napajanje            | 3ph 400/690V 50Hz |
| R.P.M.               | 1450              |
| Slobodni prolaz (mm) | 100               |
| Izlaz (mm)           | DN 150            |
| Masa (Kg)            | 361               |

### Dimenzije (mm)

▽ MINIMALNI NIVO POTAPANJA

