

Napajanje	3ph 400/690V 50Hz
R.P.M.	2850
Slobodni prolaz (mm)	10
Izlaz (mm)	DN 65
Masa (Kg)	150

Krivulja N°	Code	Tip pumpe	MOTOR			ATEX code 
			Nomin. snaga P2 (kW)	Nomin. struja I (A)	Startna struja Is (A)	
1	7008622	G213R6D1-L10AA2	15,9	30	171	7009365
2	7008180	G213R6D2-L10AA2	14,9	29	171	7008442
3	7008371	G213R6D3-L10AA2	12	26,5	156	7008447

Dimenzije (mm)

 MINIMALNI NIVO POTAPANJA

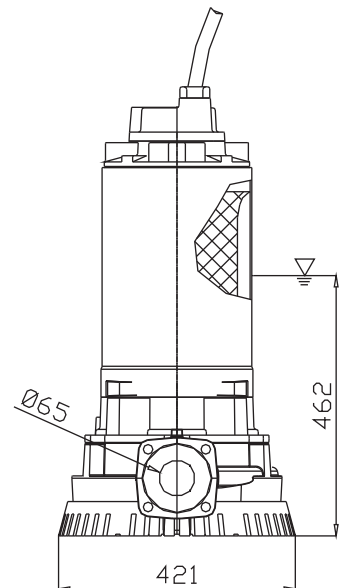
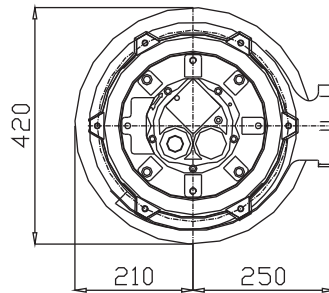
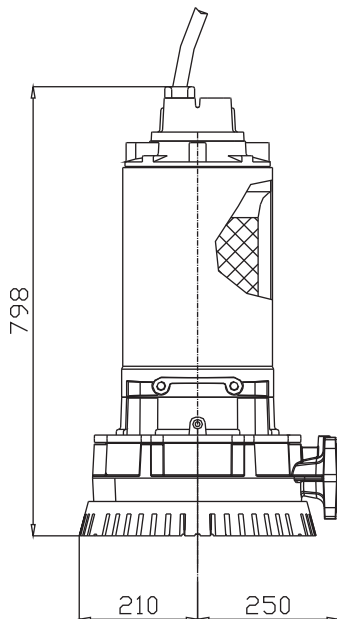

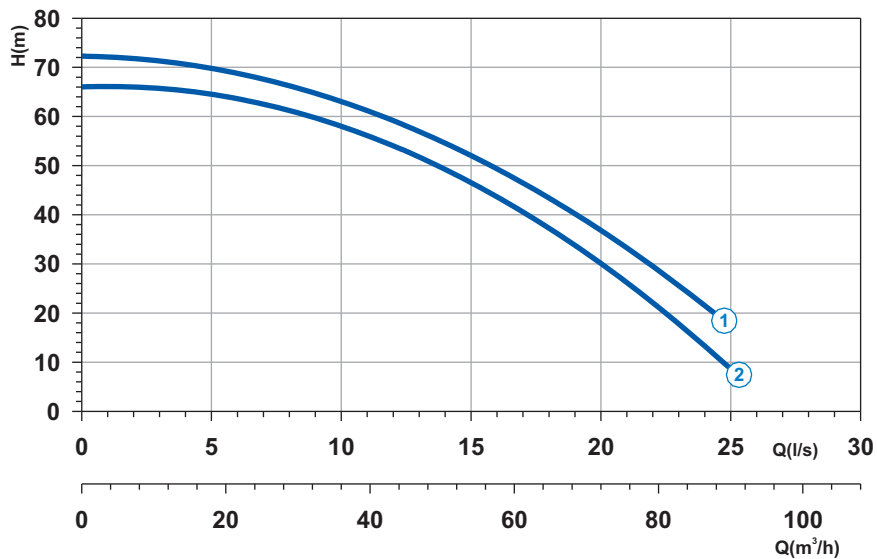

Krivulja N°	Code	Tip pumpe	MOTOR			ATEX code	
			Nomin. snaga P2 (kW)	Nomin. struja I (A)	Startna struja Is (A)		
1	7008454	G216R6D1-L10AA2	21,4	38,5	227	-	
2	7008502	G216R6D2-L10AA2	21,4	38,5	227	-	

Napajanje	3ph 400/690V 50Hz
R.P.M.	2850
Slobodni prolaz (mm)	10
Izlaz (mm)	DN 65
Masa (Kg)	200

Dimenzije (mm)

