



# Fire fighting systems

with EN 12845 Standard (European Standard)

06.12





# Index

## INTRODUCTION

<b>Company Profile</b>	
1.1 WHO WE ARE?	p. 8
<b>Fire Fighting System</b>	
2.1 INTRODUCTION AND PRODUCT DESCRIPTION	p. 10

## PRODUCTS

<b>Fire Fighting units with horizontal pumps back pull-out type</b>	
3.1 FIRE FIGHTING WITH 1 ELECTRIC MAIN PUMP MODULE	
Tables	p. 14
Dimensions	p. 18
3.2 - FIRE FIGHTING WITH 1 DIESEL MAIN MOTORPUMP MODULE	
Tables	p. 22
Dimensions	p. 26
3.3 - FIRE FIGHTING WITH 1 ELECTRIC MAIN PUMP + 1 JOCKEY PUMP	
Tables	p. 30
Dimensions	p. 34
3.4 - FIRE FIGHTING WITH 1 DIESEL MAIN MOTORPUMP + 1 JOCKEY PUMP	
Tables	p. 38
Dimensions	p. 42
3.5 - FIRE FIGHTING WITH 2 ELECTRIC MAIN PUMPS + 1 JOCKEY PUMP	
Tables	p. 46
Dimensions	p. 50
3.6 - FIRE FIGHTING WITH 1 ELECTRIC MAIN PUMP + 1 DIESEL MAIN MOTORPUMP + 1 JOCKEY PUMP	
Tables	p. 54
Dimensions	p. 58
<b>Fire Fighting units with bore hole (submersible) pumps</b>	
4.1 - FIRE FIGHTING WITH 1 ELECTRIC MAIN PUMP + 1 JOCKEY PUMP	
Tables	p. 62
Dimensions	p. 68
4.2 - FIRE FIGHTING WITH 2 ELECTRIC MAIN PUMP + 1 JOCKEY PUMP	
Tables	p. 76
Dimensions	p. 82
<b>Required components</b>	
5.1 – ECCENTRICS REDUCTIONS	p. 92
5.2 – INTERCEPTION BUTTERFLY VALVES “LUG” TYPE	p. 93
5.3 – RUBBER WEDGE GATE VALVES WITH POSITION INDICATOR	p. 94
5.4 – THREADED BRASS GATE VALVES	p. 94
5.5 – ELASTIC VIBRATION COMPENSATORS	p. 94
5.6 – BOTTOM VALVES COMPLETE WITH STRAINER	p. 95
5.7 – PRIMING TANKS WITH EN 12845 STANDARD	p. 96
5.8 – KIT FLOWMETER	p. 96
5.9 – DIRECT READING FLOWMETER	p. 96

5.10 – PUMPCOMPARTMENT KIT SPRINKLER PROTECTION	p. 97
5.11 – SELF-POWERED REMOTE ACOUSTIC/LUMINOUS ALARMS	p. 97
5.12 – FLOW RECIRCULATION VISUAL INDICATORS	p. 98
5.13 – DIESEL ENGINE SPARE PARTS KIT	p. 98
5.14 – MEMBRANE PRESSURE TANKS	p. 98
5.15 – HEAT EXCHANGERS WATER/WATER FOR DIESEL ENGINES	p. 99
<b>Hydraulic diagram</b>	
6.1 – HYDRAULIC DIAGRAM OF FIRE FIGHTING UNIT COMPLETE WITH 2 MAIN PUMPS + 1 JOCKEY PUMP	p. 100
6.2 – HYDRAULIC DIAGRAM OF FIRE FIGHTING UNIT COMPLETE WITH SUCTION LIFT INSTALLATION	p. 100
6.3 – HYDRAULIC DIAGRAM OF FIRE FIGHTING UNIT COMPLETE WITH POSITIVE HEAD INSTALLATION	p. 101
<b>Picture of some of our realizations</b>	p. 103
<b>Sales general conditions</b>	p. 112



COLOUR INDEX

**Area 1**  
Company profile

**Area 2**  
Fire fighting system

**Area 3**  
Fire fighting units with horizontal pumps back pull-out type

**Area 4**  
Fire fighting units with bore hole (submersible) pumps

**Area 5**  
Required components

**Area 6**  
Schemi idraulici

**Area 7**  
Picture of some of our realizations

# 1.1



fourgroup:

*Dynamic & Sports-minded*



## WHO WE ARE

FOURGROUP is one of leaders company in the market. His production is focused on high quality standard and design. FOURGROUP in one of the most important manufacturers and distributors of products for clean and waste water treatment and control and transformation of energy. FOURGROUP has always given its full attention to customer's needs and developing great sensibility. Innovative solution and the costant research for new a high standard quality products, make FOURGROUP one of the most innovative companies and a reference point in the market.



## PASSION FOR CHALLENGES

Fourgroup products and brands have always represented a continuous challenge in the international manufacturing market: this commitment is also represented in Sport, where Fourgroup supports one young but leading Team!

## 2.1

### FIRE FIGHTING SYSTEMS - INTRODUCTION AND PRODUCT DESCRIPTION

The Fourgroup fire fighting units are built in conformity with EN12845 standard, for automatic sprinkler systems, and with UNI10779 standard for hydrant systems.

All the main components of the booster set are factory connected and assembled in accordance with these standards.

The configuration of the booster set depends on the number of pumps installed and on the type of electric motor or diesel engine; two main service pumps, one backing up the other, are normally installed for fire-fighting systems. The choice of electric motors or diesel engines depends on the level of reliability required from the system.

EN 12845 standard (point 10.2) in case of superior or duplicate water supplies, and if more than one pump is installed, no more than one service pump can be driven by the electric motor.

Fire-fighting units are often equipped with one electric service pump and one diesel service pump.

It is important to fit the units with a jockey pump, with which the system pressure level can be maintained without having to start the main pumps.

#### Operation

The pumps start operating after a fall in the pressure level in the fire extinguishing system.

The first pump to be triggered is the jockey pump. If this pump cannot restore the pressure level, the main pump starts. When there is more than one main pump, the pumps start in cascade sequence, with the starting pressure switches set at different pressure levels.

The pressure switches of the main pumps are used only for starting, as the pumps must be stopped manually for EN 12845 units or automatically with a timer for UNI 10779 sets.

The recirculation diaphragm allows for operation of the main pumps also when the delivery port is closed (with no consumption of water in the system), avoiding overheating of the water inside the pump body.

The Fourgroup fire fighting units are configured according to EN 12845 standard, they are also one by one factory tested and they may be composed of:

- 1 or 2 main "back pull-out" pumps (coupling with electric motor or diesel engine)
- 1 or 2 main submersible borehole pumps

#### Electric Motors

- Two-pole induction type, 50 Hz, n = 2,900 rpm - Three-phase 230/400V ± 10% up to 3 kW - 400/690V ± 10% 4 kW and higher - Insulation class F - Protection IP 54 for close coupled pumps, IP 55 for pumps with coupling and IP 68 for submersible borehole pumps.

#### Diesel motors

- These are direct-injection pumps fitted with electric control box, fuel tank, starter batteries and silencer.

The fire fighting booster set is built and completed with the following main components:

- jockey electric pump (if specified). The jockey pump is automatically started and stopped by its pressure switch in order to restore supply pressure, this prevents the service pumps from starting and activating the main alarms (The maximum pressure developed by the jockey pump is always greater than the pressure of the main pumps). Jockey pump can be a self-priming jet pump, a vertical multistage pump or a submersible borehole pump. If the fire fighting unit is completed with the jockey pump, there are also included: cylindrical 20-liter membrane pressure tank (16 bar), ball valve, non-return valve on delivery, pressure gauge and an electric panel in the automatic mode
- a control panel for each service pump
- two pressure switches for each service pump (if the first fails, the second repeats permission for the pump to start)
- on the discharge side of each service pump there are: a pressure switch to indicate the pump is operating, a on-off valve, a pressure gauge, a check valve and a tap for connection to the priming circuit for suction lift installations. If the service pump works with a closed discharge line, a water recirculation tap has been applied to the pump body in order to prevent the pump from overheating
- for each main pump there are manual test circuit with pressure switches, pressure gauge, non return valve and ball valve
- delivery manifold connected to each pump
- suction manifold is never supplied
- single base containing all the booster set components within a compact structure and ready for installation

To complete the pump station as requested by the EN 12845 standard, the booster sets needs the following accessories:

- suction side kit
- flow meter and manifold for flow meter
- alarm panel
- set of spare parts for diesel engines.
- priming tank with accessories (for suction lift installations only)

### CONTROL PANELS



#### Electric main-pump control panel (electric motor)

Each main pump has its own electric control board housed in a metal cabinet with IP54 protection. The box contains the devices required for operation and control of the pump. Electric motor starting is direct for power ratings up to 9.2 kW (Hp 12.5), for motors with a rating equal to or higher than 11 kW (Hp 15) pump starting is of the star-delta type. For borehole pumps with motors equal to or higher than 11 kW (Hp 15) pump starting is of the statoric type with impedance.

Features of control panel for electric main pump (star-delta type)

- Electromechanical control panel for electric Star/Delta pump
- Input voltage 3 ~ 50/60Hz 400V ±10%
- Transformer 400 V/24 V for auxiliary circuit
- Very low voltage input for no. 2 pressure switches of start(NC contact with system in pressure and electric pump off)
- Very low voltage input for control of the electric pump from float switch in the priming tank (NO contact with tank full of water)
- Very low voltage input for signaling of electric pump in pressure/on from pressure switch (NO contact with system in pressure and electric pump off)
- Selector with key automatic-0-emergency: in automatic position starting of the pump by electronic unit, in emergency position immediate starting of the pump
- Electronic unit for electric pump control
- Pushbuttons for stop/start of the pump for manual test
- Pushbutton for test of the electronic unit's lights
- Pushbutton for scrolling the functions of the unit
- LCD Display for the visualization of n° 3 voltmeters, n° 3 ammeters, frequency-meter, wattmeter, varmeter, volt-ammeter, cosφ-meter, total run meter, partial run meter, history of the events

- Signaling lights
- Operation mode according to UNI10779 with timer for delay of stop of the electric pump adjustable from 1' to 30'
- Visualizations of the display settable in 5 languages: Italian, English, Spanish, German, French
- Functions of delay and specific alarms settable from electronic unit (refer to the manual enclose to the panels)
- Contactor for control of the electric pump dimensioned in AC3
- Auxiliary and motor protection fuses
- Main switch with interlocking door
- Alarm output with exchangeable contact (max 5A 250V AC1) for signaling of "voltage supply available"
- Alarm output with exchangeable contact (max 5A 250V AC1) for signaling of "request for pump starting"
- Alarm output with exchangeable contact (max 5A 250V AC1) for signaling of "pump running"
- Alarm output with exchangeable contact (max 5A 250V AC1) for signaling of "start failed"
- Steel enclosure
- Protection IP54

#### On request:

- Timer for pumps stop after 20 minutes (UNI 10779)



### Diesel main-pump control panel (diesel engine)

This control panel contains the control devices for the control of the diesel motor and the battery chargers for feeding the starter accumulators.

Features of control panel for diesel main motor-pump

- Electromechanical control panel for diesel pump
- Input voltage 1 ~ 50/60Hz 230V ±10%
- Input from n°02 external lead batteries for control of the starting motor and supply of auxiliary circuits
- Very low voltage input for control from n° 2 call/start pressure switches in series (NC contact with system in pressure and diesel pump stopped)
- Very low voltage input for control of the diesel pump from float switch in the priming tank (NO contact with tank full of water)
- Very low voltage input for signaling of electric pump in pressure/on from pressure switch (NO contact with diesel pump off)
- Electronic unit for diesel pump control
- Selector with key automatic-manual: in automatic position starting of the diesel pump by electronic unit, in manual position starting of the diesel pump by start pushbutton of the electronic unit
- Pushbuttons for manual start of the diesel pump
- Pushbutton for manual shut off of the diesel pump
- Pushbutton for restoring from anomalies
- Pushbutton for testing the manual start (active in case of failure of automatic start)
- Pushbutton for test of the electronic unit's lights
- Pushbutton for scrolling the functions of the unit
- Pushbuttons for Manual Emergency protected by "Safe crash"
- LCD Display for the visualization of n° 2 batteries' voltmeters, n° 2 batteries'ammeters, round meters, total run meter, partial run meter, indicator of fuel level, water thermometer, oil thermometer, oil manometer, batteries starting counter, history of the events

- Signaling lights
- Operation mode according to UNI10779 with timer for delay of stop of the electric pump adjustable from 1' to 30'
- Visualizations of the display settable in 5 languages: Italian, English, Spanish, German, French
- Functions of delay and specific alarms settable from electronic unit (refer to the manual enclose to the panels)
- N°02 battery chargers 12Vdc 3A (24Vdc 3A for 24V version)
- Auxiliary protection fuses
- Main switch with interlocking door
- Alarm output with exchangeable contact (max 5A 250V AC1) for signaling of "automatic operation excluded"
- Alarm output with exchangeable contact (max 5A 250V AC1) for signaling of "control panel breakdown"
- Alarm output with exchangeable contact (max 5A 250V AC1) for signaling of "diesel pump operating"
- Alarm output with exchangeable contact (max 5A 250V AC1) for signaling of "start failed"
- Steel enclosure
- Output with cable holder
- Protection IP54

#### On request:

- Timer for pumps stop after 20 minutes (UNI 10779)



### Electric jockey-pump control panel

When the jockey pump is installed, there is an electric control panel that controls and protects the pump.

Features of control panel for electric jockey pump (direct starting)

- Electronic control panel
- Input voltage 3~50/60 Hz 400V ±10% (three-phase)
- Very low voltage input for external pressure switch or float switch
- Very low voltage input for 3 level probes
- Probes suitable for conductive not inflammable liquids
- Selector for filling/emptying operation of the level probes
- Internal adjuster for probes
- Selector for automatic-off-manual motor operation (manual temporary)
- Green led for power on
- Green led for motor operating
- Red led for water level alarm
- Red led for motor overload protection alarm
- Adjustable electronic protection from motor overload
- Time for activation of protection: 5"
- Auxiliary circuits and motor protection fuse
- Alarm output with exchangeable contacts 5 A 250 V (resistive load)
- Main switch with door interlock
- Box in ABS
- Output with cable holder
- Protection IP54

# 3.1

Fire fighting units with horizontal pumps back pull-out type, made according to standard EN 12845

## 1 Electric main pump module "E" series

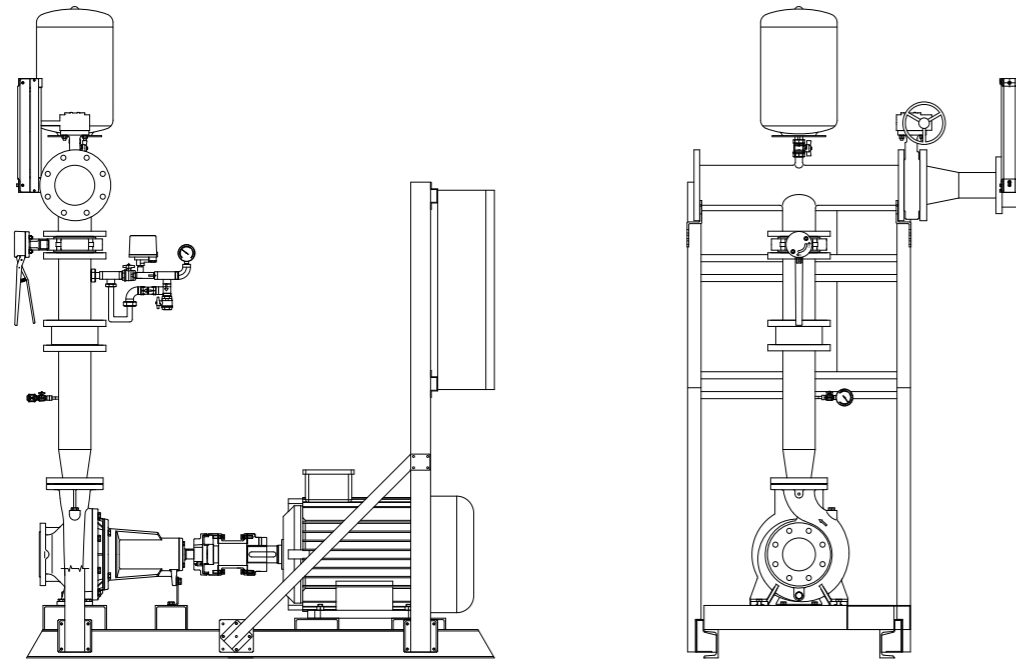

Fire fighting unit according to standard EN 12845, consists of 1 electric main pump module:

Main centrifugal pump "back pull-out" type in according to EN 733 (formerly DIN 24255) axial suction and radial discharge, cast iron pump casing, mechanical seal, coupling performed by means of flexible coupling spacer with three-phase asynchronous electric motor. The fire fighting unit is complete with a main electric pump mounted on a painted steel base and electrically wired to the electrical control panel installed on board skid (for power ≥ 160 kW the electric panel of the main pump is supplied loose cabinet metal

size = WxHxD mm 800x1800x430 and its wiring with the group will be at the customer). The standard supply of the Fire unit Series "E" does not include either the suction valve or suction eccentric enlargement of the main pump, which must be ordered separately (suction reducing eccentric be sized according to the directions of the standard EN 12845).

Fire fighting units with horizontal pumps back pull-out type, made according to standard EN 12845

## 1 Electric main pump module "E" series

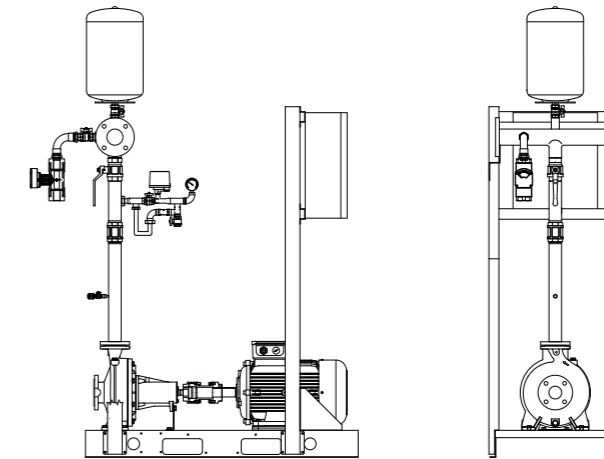

Units with capacity from m³/h 0 up to m³/h 96

Code	Model	Electric Power (kW)	Q= CAPACITY OF EACH SERVICE PUMP																		
			m³/h	7,2	9	14,4	18	21,6	24	27	28,8	30	36	43,2	50,4	54	60	72	84	90	96
			0	120	150	240	300	360	400	450	480	500	600	720	840	900	1000	1200	1400	1500	1600
H= Total head ( m.c.a. )																					
700.001	E-L32-200/188-4	3	44	41	40	35	32*	27	24	20											
700.002	E-L32-200/204-5,5	4	54	51	45	45	42	37*	34	30	27	26									
700.003	E-S32-200N/206-7,5	5.5	54			51	49	46	44*	40	36	35									
700.004	E-S32-200N/219-10	7.5	63			62	61	60	57*	54	52	50	36								
700.005	E-L32X-250/256-15	11	86			74	71	66*	63	59											
700.006	E-C32-250/225-20	15	69				69	68	67	65	63	62*	53								
700.007	E-C32-250/235-20	15	77				76	75	74	73	71	70*	61								
700.008	E-C32-250/255-25	18.5	89				89	88	87	85	84	83	75*	60							
700.009	E-C32-250/264-25	18.5	96				95	94	92	91	89	88	80*	64							
700.010	E-S40-200/190-10	7.5	46				44	43	41	40	39	38*	33	26	20						
700.011	E-L40-200/209-10	7.5	57				54	52	51	50	49	48	46*	41							
700.012	E-S40-200/212-12,5	9.2	58				58	56	55	54	53	52	47*	41	35						
700.013	E-L40-250/233-15	11	72				68	65	64	63	62	61	57	52*	44						
700.014	E-L40-250/251-20	15	85				80	78	77	75	74	73	70	65*	56	53					
700.015	E-S40-250N/240-25	18.5	81						79	78	77	76	75	69	68*	65	61	51			
700.016	E-S40-250N/255-30	22	95						89	88	87	86	84	80	76*	74	69	55			
700.017	E-S40-250N/259-40	30	98						92	91	91,5	90	87	81	79*	76	71	59			
700.018	E-L50-200/197-15	11	51									48	47	45	42	41	38*	33	26		
700.019	E-L50-200/209-15	11	58									55	54	53	50	49	43*	40	33	29	
700.020	E-L50-250/224-20	15	68										64	63	60	59	56*	50	41		
700.021	E-L50-250/237-25	18.5	77										73	72	70	68	66	60*	52	47	
700.022	E-L50-250/250-30	22	86										83	81	79	78	75	70*	61	57	52
700.023	E-C50-250/255-40	30	95										92	90,5	88	86	83*	72	50	36	
700.024	E-C50-250/264-50	37	104										101	99	96	94	91	83*	61	54	26
700.025	E-CH50-315/291-75	55	118										114	113	110	108	106	98*	82	74	
700.026	E-CH50-315/308-100	75	132										129	127	125	123	122	116	106*	100	90

Tolerances in table: ISO 9906 Annex A (performance at the outlet of the pump)  
 Gray boxes: NPSH ≥ 5m (possible installation only with positive suction head)  
 \* maximum efficiency point

## Fire fighting units with horizontal pumps back pull-out type, made according to standard EN 12845

### 1 Electric main pump module “E” series

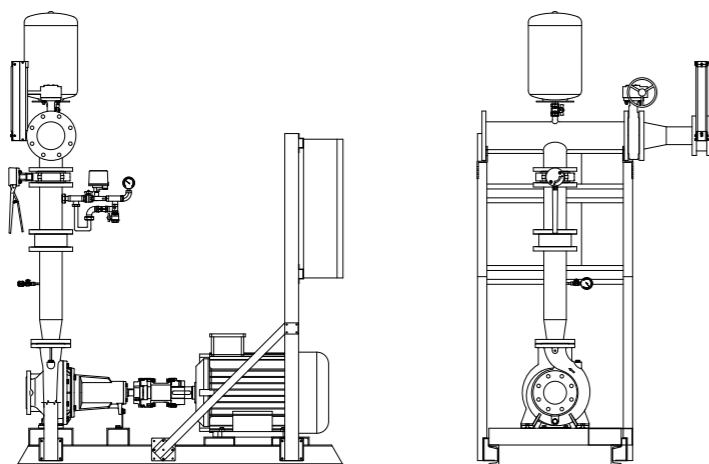

Units with capacity from m³/h 66 up to m³/h 360

Code	Model	Electric Power (kW)	Q= CAPACITY OF EACH SERVICE PUMP															
			m³/h 0	66	72	90	108	120	150	180	210	240	270	300	330	360		
			l/m 0	1100	1200	1500	1800	2000	2500	3000	3500	4000	4500	5000	5500	6000		
H= Total head ( m.c.a. )																		
700.027	E-L65-200/187-20	15	45	44	43	40*	37	34										
700.028	E-S65-200N/192-30	22	50	50	48	46*	43	40	30	15								
700.029	E-L65-200/198-25	18.5	52	51	51	48	45*	42										
700.030	E-L65-200/210-30	22	59	59	58	55	52*	50										
700.031	E-S65-200N/215-40	30	65	64	64	61	58*	55	46	34								
700.032	E-L65-250/241-40	30	76	74	73	69	64*	61										
700.033	E-L65-250/258-50	37	90	87	86	83	78*	75										
700.034	E-S65-250N/222-40	30	70	68	67	65	62*	59	51									
700.035	E-S65-250N/245-60	45	83	82	82	79	76	73*	65									
700.036	E-S65-250N/255-60	45	92	92	91	89	85	83*	74	65								
700.037	E-S65-250N/259-75	55	95	94	93	92	88	85*	76	69								
700.038	E-S65-315R/273-75	55	101	100	99	96	93*	90	84									
700.039	E-S65-315R/282-100	75	112	111	110	108	105*	103	96	87								
700.040	E-L80-200/189-30	22	48				45	44	38*	32								
700.041	E-L80-200/207-40	30	60				58	57	52*	46	40							
700.042	E-L80-250/225-50	37	71				67	65	58*	49								
700.043	E-L80-250/238-60	45	80				78	76	70*	62								
700.044	E-L80-250/256-75	55	92				91	90	84	76*	68							
700.045	E-L80X-250/270-100	75	112				108	106	101	94*	83							
700.046	E-C80-200/205-60	45	58				56	53	50*	46	42							
700.047	E-C80-200/214-75	55	64				62	60	57	53*	49							
700.048	E-C80-250/235-75	55	75				70	68	64*	57	44	30						
700.049	E-C80-250/255-100	75	89				85	84	80	75*	68	56	38					
700.050	E-C80-250/264-100	75	106				90	89	87	83*	76	66	52					
700.051	E-S80-250/269-150	110	102				102	100	98	95	92*	88	85	82	77			
700.052	E-S80-315R/302-150	110	117				115	113	112	108*	103	90						

Tolerances in table: ISO 9906 Annex A (performance at the outlet of the pump)  
Gray boxes: NPSH ≥ 5m (possible installation only with positive suction head)  
\* maximum efficiency point

## Fire fighting units with horizontal pumps back pull-out type, made according to standard EN 12845

### 1 Electric main pump module “E” series

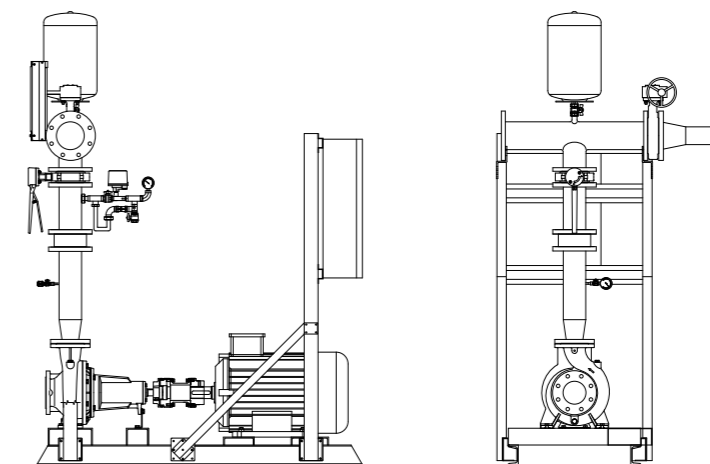

Units with capacity from m³/h 150 up to m³/h 750

Code	Model	Electric Power (kW)	Q= CAPACITY OF EACH SERVICE PUMP																	
			m³/h 0	150	180	210	240	270	300	330	360	390	420	480	540	600	650	700	750	
			l/m 0	2500	3000	3500	4000	4500	5000	5500	6000	6500	7000	8000	9000	10000	10833	11667	12500	
H= Total head ( m.c.a. )																				
700.053	E-L100-200/192-40	30	49	45	42	38*	34	30	24											
700.054	E-L100-200/203-50	37	56	52	50	46	42*	38	33	26										
700.055	E-L100-250/221-60	45	69	65	59	56*	50	45	35											
700.056	E-L100-250/235-75	55	79	75	72	69	64*	56	50											
700.057	E-L100-250/254-100	75	92	89	86	84	80	75*	67											
700.058	E-L100-250/267-125	90	103	100	98	95	90	85*	80											
700.059	E-S100-200/219-75	55	62,5	60	59	57,5	55	52,5	49*	43	37,5									
700.060	E-S100-250/233-100	75	68	67	64	61	57	55*	49	43	30									
700.061	E-S100-250/250-100	75	80	79	77	75	72	69	64*	59	53									
700.062	E-S100-250/265-125	90	95	92	90	88	86	84	80*	75	70									
700.063	E-S100-250/269-150	110	97	95	94	92	90	86	83*	78	74									
700.064	E-CH100-315/291-150	110	117	114	111	108	102	96*	87	74										
700.065	E-CH100-315/308-180	132	131	130	128	124	120	115	106*	96	84									
700.066	E-L125-200/206-60	45	47					38	36	34	32	30*	28	22						
700.067	E-L125-200/216-75	55	57					49	47	45	42	40	38*	31	22					
700.068	E-CH125-250/222-100	75	59					55	53	50*	47	43								
700.069	E-L125-270/224-100	75	65					59	56	55	53	50*	48	47	35					
700.070	E-L125-270/237-125	90	75					70	68	65	65	61	60*	54	45	36				
700.071	E-L125-270/253-150	110	88					82	80	78	76	74	71	66*	57	46				
700.072	E-CH125-250/264-180	132	91					90	88	86	84	81	77*	72	62					
700.073	E-L125-270/266-180	132	97					91	90	87	86	84	81	76*	70	60				
700.074	E-CH125-250/278-218	160	102					101	100	99	97	95	93	87*	80	71				
700.075	E-S125-315R/302-272	200	124					118	117	115	112	109*	105	102	90					
700.076	E-S150-315R/257-218	160	70						68	67	66	64	62	58	52*	47	42	35		
700.077	E-S150-315R/266-218	160	85						82	81	80	78	76	72	68*	62	56	50		
700.078	E-S150-315R/280-272	200	97						94	93	92	90	88	85	80*	75	70	62	53	
700.079	E-S150-315R/290-340	250	107							106	105	103	102	101	97	95*	90	85	80	75

Tolerances in table: ISO 9906 Annex A (performance at the outlet of the pump)  
Gray boxes: NPSH ≥ 5m (possible installation only with positive suction head)  
\* maximum efficiency point

## Dimensions - Fire fighting units Series "E"

Fire fighting units with horizontal pumps back pull-out type  
1 Electric main pump module

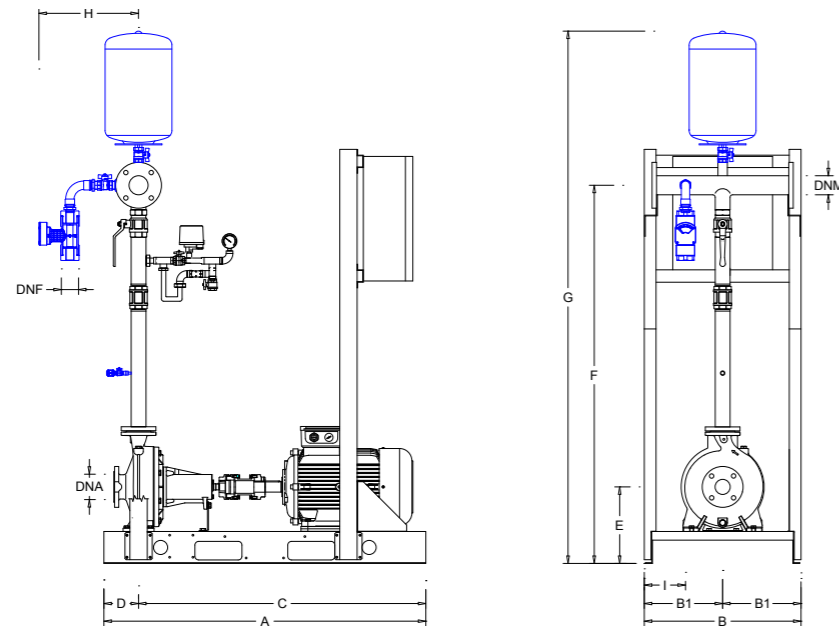

Units with capacity from m<sup>3</sup>/h 0 up to m<sup>3</sup>/h 96

Fire Fighting Unit		Flow meter kit	Connections			Dimensions (mm)																			
Code	Model		DNA	DNM	DNF	A	B	B1	C	D	E	F	G	H	I										
700.001	E-L32-200/188-4	KA-32-32	DN50	DN65	1 1/2"	1300	633	316,5	1160	140	290	1428*	2050*	405*	150										
700.002	E-L32-200/204-5,5										1533*	2155*													
700.003	E-S32-200/206-7,5										1493*	2115*													
700.004	E-S32-200N/219-10										1527*	2150*													
700.005	E-L32X-250/256-15										KA-40-40	DN65	1 1/2"			1300	633	316,5	1160	140	290	1428*	2050*	405*	150
700.006	E-C32-250/225-20																				1533*	2155*			
700.007	E-C32-250/235-20																				1493*	2115*			
700.008	E-C32-250/255-25																				1527*	2150*			
700.009	E-C32-250/264-25										KA-40-40	DN65	1 1/2"			1300	633	316,5	1160	140	310	1493*	2115*	405*	150
700.010	E-S40-200/190-10	1527*	2150*																						
700.011	E-L40-200/209-10	KA-50-50	DN65	2"	1300	633	316,5	1160	140	290				1428*	2050*						405*	150			
700.012	E-S40-200/212-12,5									1533*				2155*											
700.013	E-L40-250/233-15									1493*				2115*											
700.014	E-L40-250/251-20	KA-50-50	DN65	2"	1300	633	316,5	1160	140	310				1493*	2115*						405*	150			
700.015	E-S40-250N/240-25									1527*				2150*											
700.016	E-S40-250N/255-30									KB1-65-65	DN80	2"	1300	633	316,5	1160	140	290	1503	2125			405*		
700.017	E-S40-250N/259-40																	1563	2185	432					
700.018	E-L50-200/197-15	KA-50-50	DN65	DN80	1300	633	316,5	1160	140	310	1548	2170	405*	150											
700.019	E-L50-200/209-15										1582	2187	432												
700.020	E-L50-250/224-20										KB1-65-65	DN65	2"		1650	786	393	1480	170	340	1605	2232	405*		
700.021	E-L50-250/237-25																			390	1665	2292	432		
700.022	E-L50-250/250-30										KA-50-50	DN65	2"		1800	786	393	1480	170	390	1665	2292	432		
700.023	E-C50-250/255-40																			420	1665	2292	432		
700.024	E-C50-250/264-50	KB1-65-65	DN65	2"	1900	786	393	1480	170	390	1665	2292	432												
700.025	E-CH50-315/291-75									420	1665	2292	432												
700.026	E-CH50-315/308-100																								

\* Tolerance of ± 50 mm  
blue components: optional available on request

## Dimensions - Fire fighting units Series "E"

Fire fighting units with horizontal pumps back pull-out type  
1 Electric main pump module

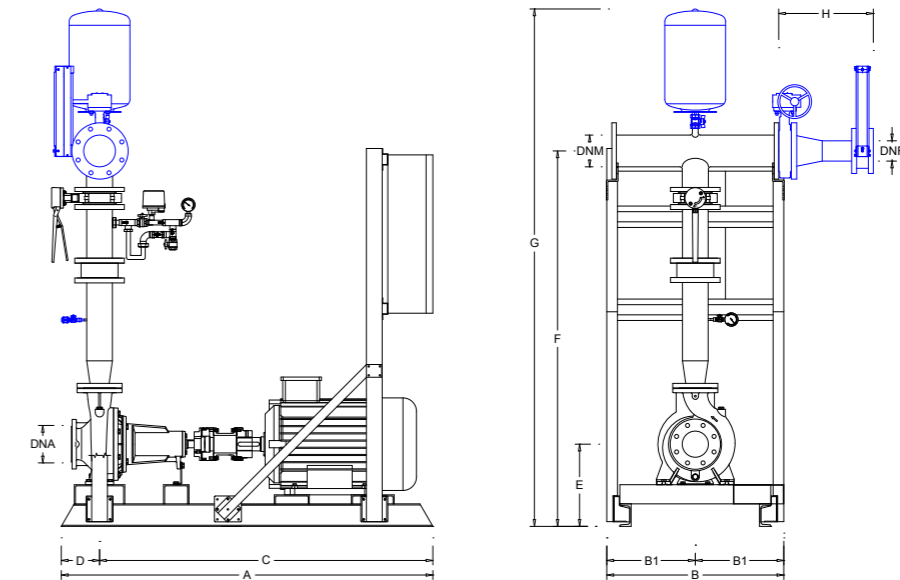

Units with capacity from m<sup>3</sup>/h 66 up to m<sup>3</sup>/h 360

Fire Fighting Unit		Flow meter kit	Connections			Dimensions (mm)									
Code	Model		DNA	DNM	DNF	A	B	B1	C	D	E	F	G	H	
700.027	E-L65-200/187-20	KB2-100-65	DN80	DN100	1300	633	316,5	1160	140	310	1581	2216	397		
700.028	E-S65-200N/192-30										1615	2233	402		
700.029	E-L65-200/198-25	KB2-100-65	DN80	DN100	1300	633	316,5	1160	140	310	1615	2233	397		
700.030	E-L65-200/210-30										1615	2233	397		
700.031	E-S65-200N/215-40	KB2-100-80	DN80	DN100	1650	786	393	1480	170	360	1644	2262	402		
700.032	E-L65-250/241-40										1644	2262	402		
700.033	E-L65-250/258-50	KB2-100-80	DN80	DN100	1650	786	393	1480	170	360	1644	2262	402		
700.034	E-S65-250N/222-40										1644	2262	402		
700.035	E-S65-250N/245-60										1644	2262	402		
700.036	E-S65-250N/255-60										1644	2262	402		
700.037	E-S65-250N/259-75										1644	2262	402		
700.038	E-S65-315R/273-75										1644	2262	402		
700.039	E-S65-315R/282-100										1644	2262	402		
700.040	E-L80-200/189-30	KB2-125-80	DN80	DN100	1358	633	316,5	1160	140	310	1684	2315	426		
700.041	E-L80-200/207-40										1684	2315	426		
700.042	E-L80-250/225-50	KB2-125-80	DN80	DN100	1650	786	393	1480	170	340	1667	2298	420		
700.043	E-L80-250/238-60										1667	2298	420		
700.044	E-L80-250/256-75	KB2-125-80	DN100	DN125	1800	786	393	1630	170	390	1717	2348	426		
700.045	E-L80X-250/270-100										1717	2348	426		
700.046	E-C80-200/205-60										1717	2348	426		
700.047	E-C80-200/214-75										1717	2348	426		
700.048	E-C80-250/235-75										1717	2348	426		
700.049	E-C80-250/255-100										1717	2348	426		
700.050	E-C80-250/264-100	KC-125-100	DN100	DN100	1800	1046	523	2015	185	475	1832	2463	420		
700.051	E-S80-250/269-150										1832	2463	420		
700.052	E-S80-315R/302-150										1832	2463	420		

\* Tolerance of ± 50 mm  
blue components: optional available on request



# 3.2

Fire fighting units with horizontal pumps back pull-out type, made according to standard EN 12845

## 1 Diesel main motorpump module "D" Series

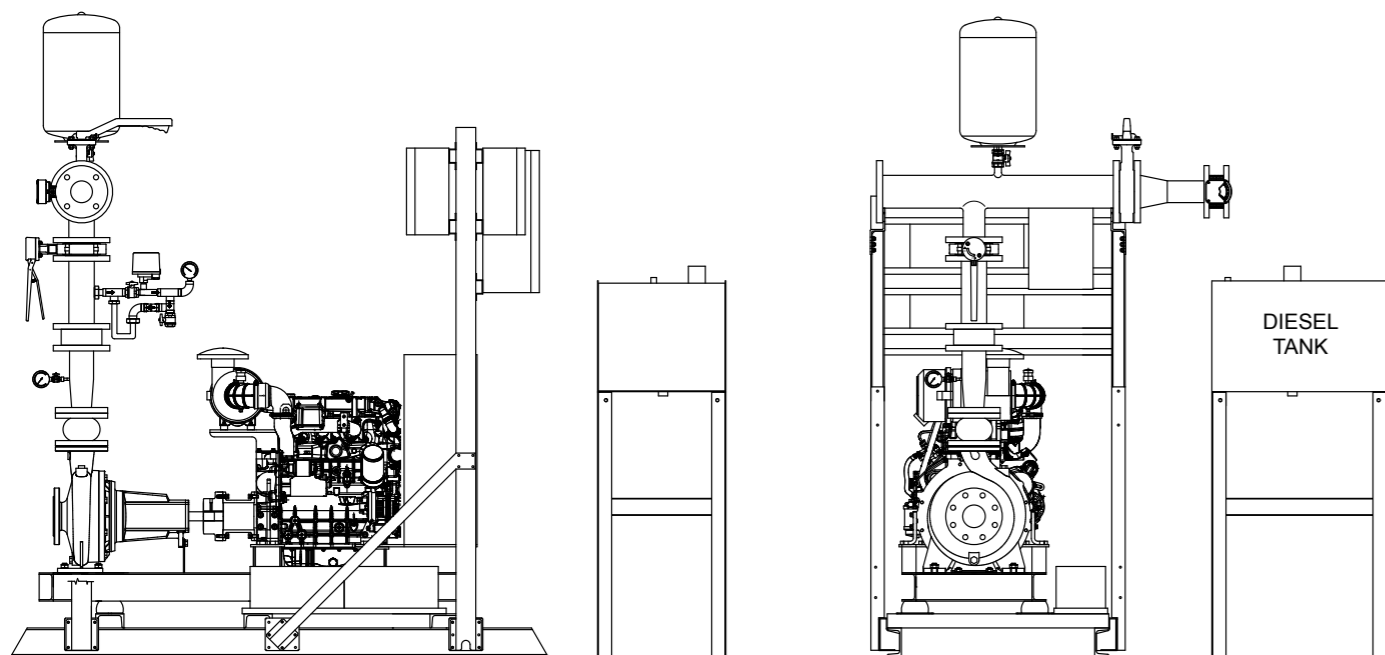

Fire fighting unit according to standard EN 12845, consists of 1 diesel main motorpump module:

Main centrifugal pump "back pull-out" according to EN 733 (formerly DIN 24255) axial suction and radial discharge, cast iron pump casing, mechanical seal, coupling performed by means of flexible coupling spacer with diesel engine fitted in compliance with EN 12845. The fire fighting unit is complete with a main pump mounted on a painted steel base, electrically wired to the electrical control panel installed on board skid. The standard supply of the Fire unit series "D" does

not include either the suction valve or suction eccentric enlargement of the main pump or elastic vibration compensator, which must be ordered separately (suction reducing eccentric be sized according to the directions of the standard EN 12845). Diesel tank included, provided on a separate pedestal.

Fire fighting units with horizontal pumps back pull-out type, made according to standard EN 12845

## 1 Diesel main motorpump module "D" Series

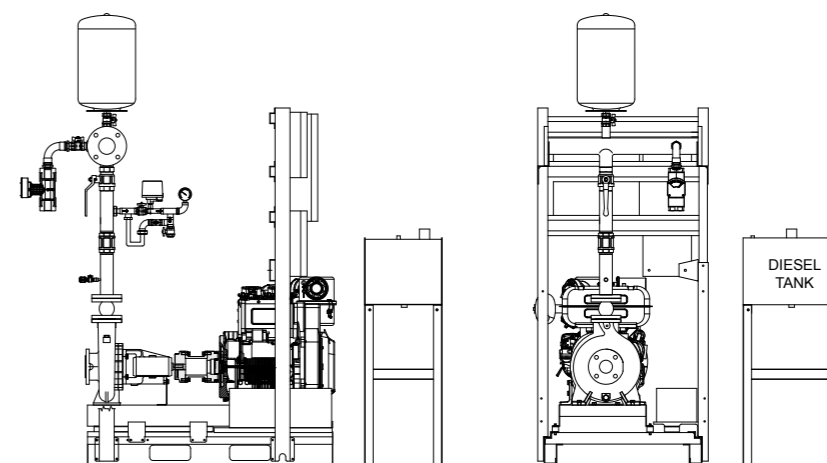

Units with capacity from m³/h 0 up to m³/h 96

Code	Model	Diesel Power kW	Q= CAPACITY OF EACH SERVICE PUMP																		
			m³/h 0	7,2	9	14,4	18	21,6	24	27	28,8	30	36	43,2	50,4	54	60	72	84	90	96
			l/m 0	120	150	240	300	360	400	450	480	500	600	720	840	900	1000	1200	1400	1500	1600
			H= Total head ( m.c.a. )																		
700.080	D-L32-200/188-5,8	4.26	44	41	40	35	32*	27	24	20											
700.081	D-L32-200/204-5,8	4.26	54	51	45	45	42	37*	34	30	27	26									
700.082	D-S32-200N/206-8,4	6.18	54			51	49	46	44*	40	36	35									
700.083	D-S32-200N/219-14,4	10.59	63			62	61	60	57*	54	52	50	36								
700.084	D-L32X-250/256-14,4	10.59	86			74	71	66*	63	59											
700.085	D-C32-250/225-18,5	13.60	69				69	68	67	65	63	62*	53								
700.086	D-C32-250/235-24	17.65	77				76	75	74	73	71	70*	61								
700.087	D-C32-250/255-24	17.65	89				89	88	87	85	84	83	75*	60							
700.088	D-C32-250/264-27	19.8	96				95	94	92	91	89	88	80*	64							
700.089	D-S40-200/190-8,4	6.18	46				44	43	41	40	39	38*	33	26	20						
700.090	D-L40-200/209-14,4	10.59	57				54	52	51	50	49	48	46*	41							
700.091	D-S40-200/212-14,4	10.59	58				58	56	55	54	53	52	47*	41	35						
700.092	D-L40-250/233-18,5	13.60	72				68	65	64	63	62	61	57	52*	44						
700.093	D-L40-250/251-24	17.65	85				80	78	77	75	74	73	70	65*	56	53					
700.094	D-S40-250N/240-27	19.8	81						79	78	77	76	75	69	68*	65	61	51			
700.095	D-S40-250N/255-36	26.47	95						89	88	87	86	84	80	76*	74	69	55			
700.096	D-S40-250N/259-36	26.47	98						92	91	91,5	90	87	81	79*	76	71	59			
700.097	D-L50-200/197-14,4	10.59	51									48	47	45	42	41	38*	33	26		
700.098	D-L50-200/209-18,5	13.60	58									55	54	53	50	49	43*	40	33	29	
700.099	D-L50-250/224-24	17.65	68										64	63	60	59	56*	50	41		
700.100	D-L50-250/237-27	19.8	77										73	72	70	68	66	60*	52	47	
700.101	D-L50-250/250-36	26.47	86										83	81	79	78	75	70*	61	57	52
700.102	D-C50-250/255-42,6	31.3	95										92	90,5	88	86	83*	72	50	36	
700.103	D-C50-250/264-42,6	31.3	104										101	99	96	94	91	83*	61	54	26
700.104	D-CH50-315/291-65,3	48	118										114	113	110	108	106	98*	82	74	
700.105	D-CH50-315/308-89,8	66	132										129	127	125	123	122	116	106*	100	90

Tolerances in table: ISO 9906 Annex A (performance at the outlet of the pump)  
 Gray boxes: NPSH ≥ 5m (possible installation only with positive suction head)  
 \* maximum efficiency point

## Fire fighting units with horizontal pumps back pull-out type, made according to standard EN 12845

### 1 Diesel main motorpump module “D” Series

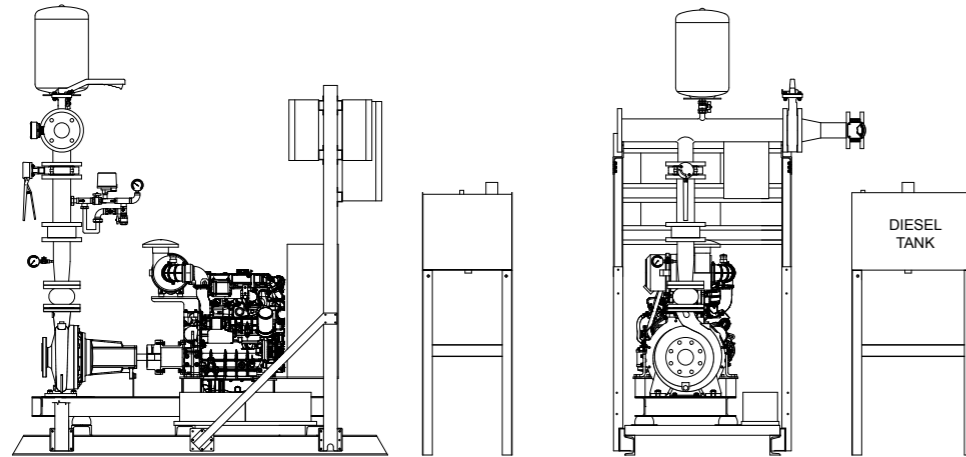

Units with capacity from m<sup>3</sup>/h 66 up to m<sup>3</sup>/h 360

Code	Model	Diesel Power kW	Q= CAPACITY OF EACH SERVICE PUMP																
			m <sup>3</sup> /h 0	66	72	90	108	120	150	180	210	240	270	300	330	360			
			l/m 0	1100	1200	1500	1800	2000	2500	3000	3500	4000	4500	5000	5500	6000			
			H= Total head ( m.c.a. )																
700.106	D-L65-200/187-24	17.65	45	44	43	40*	37	34											
700.107	D-S65-200N/192-36	26.47	50	50	48	46*	43	40	30	15									
700.108	D-L65-200/198-27	19.8	52	51	51	48	45*	42											
700.109	D-L65-200/210-36	26.47	59	59	58	55	52*	50											
700.110	D-S65-200N/215-42,6	31.3	65	64	64	61	58*	55	46	34									
700.111	D-L65-250/241-42,6	31.3	76	74	73	69	64*	61											
700.112	D-L65-250/258-50	37	90	87	86	83	78*	75											
700.113	D-S65-250N/222-42,6	31.3	70	68	67	65	62*	59	51										
700.114	D-S65-250N/245-65,3	48	83	82	82	79	76	73*	65										
700.115	D-S65-250N/255-65,3	48	92	92	91	89	85	83*	74	65									
700.116	D-S65-250N/259-65,3	48	95	94	93	92	88	85*	76	69									
700.117	D-S65-315R/273-89,8	66	101	100	99	96	93*	90	84										
700.118	D-S65-315R/282-89,8	66	112	111	110	108	105*	103	96	87									
700.119	D-L80-200/189-36	26.47	48				45	44	38*	32									
700.120	D-L80-200/207-42,5	31.3	60				58	57	52*	46	40								
700.121	D-L80-250/225-50	37	71				67	65	58*	49									
700.122	D-L80-250/238-65,3	48	80				78	76	70*	62									
700.123	D-L80-250/256-89,8	66	92				91	90	84	76*	68								
700.124	D-L80X-250/270-133,4	98.1	112				108	106	101	94*	83								
700.125	D-C80-200/205-65,3	48	58				56	53	50*	46	42								
700.126	D-C80-200/214-65,3	48	64				62	60	57	53*	49								
700.127	D-C80-250/235-65,3	48	75				70	68	64*	57	44	30							
700.128	D-C80-250/255-89,8	66	89				85	84	80	75*	68	56	38						
700.129	D-C80-250/264-133,4	98.1	106				90	89	87	83*	76	66	52						
700.130	D-S80-250/269-177,5	130.5	102				102	100	98	95	92*	88	85	82	77				
700.131	D-S80-315R/302-177,5	130.5	117				115	113	112	108*	103	90							

Tolerances in table: ISO 9906 Annex A (performance at the outlet of the pump)  
Gray boxes: NPSH ≥ 5m (possible installation only with positive suction head)  
\* maximum efficiency point

## Fire fighting units with horizontal pumps back pull-out type, made according to standard EN 12845

### 1 Diesel main motorpump module “D” Series

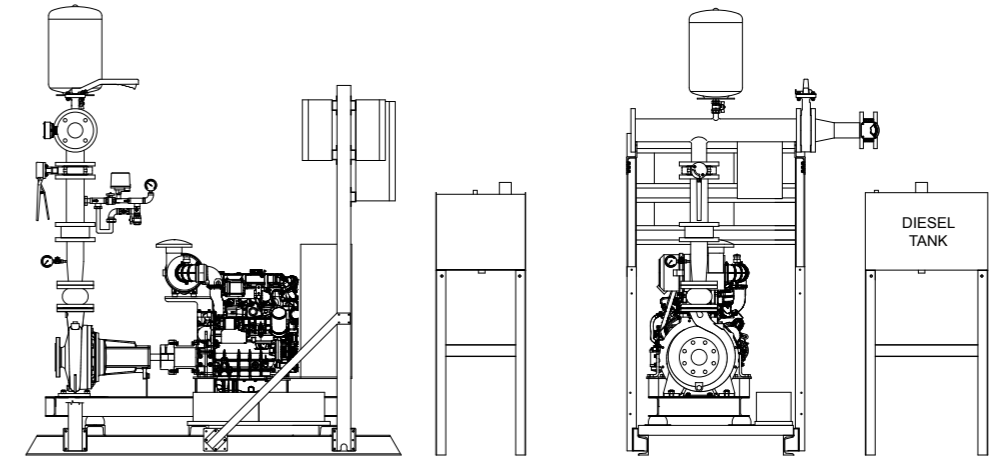

Units with capacity from m<sup>3</sup>/h 150 up to m<sup>3</sup>/h 750

Code	Model	Diesel Power kW	Q= CAPACITY OF EACH SERVICE PUMP																
			m <sup>3</sup> /h 0	150	180	210	240	270	300	330	360	390	420	480	540	600	650	700	750
			l/m 0	2500	3000	3500	4000	4500	5000	5500	6000	6500	7000	8000	9000	10000	10833	11667	12500
			H= Total head ( m.c.a. )																
700.132	D-L100-200/192-42,6	31.3	49	45	42	38*	34	30	24										
700.133	D-L100-200/203-50	37	56	52	50	46	42*	38	33	26									
700.134	D-L100-250/221-65,3	48	69	65	59	56*	50	45	35										
700.135	D-L100-250/235-89,8	66	79	75	72	69	64*	56	50										
700.136	D-L100-250/254-133,4	98.1	92	89	86	84	80	75*	67										
700.137	D-L100-250/267-133,4	98.1	103	100	98	95	90	85*	80										
700.138	D-S100-200A/219-89,8	66	62,5	60	59	57,5	55	52,5	49*	43	37,5								
700.139	D-S100-250CD/233-89,8	66	68	67	64	61	57	55*	49	43	30								
700.140	D-S100-250B/250-133,4	98.1	80	79	77	75	72	69	64*	59	53								
700.141	D-S100-250AB/265-133,4	98.1	95	92	90	88	86	84	80*	75	70								
700.142	D-S100-250A/269-133,4	98.1	97	95	94	92	90	86	83*	78	74								
700.143	D-CH100-315/291-177,5	130.5	117	114	111	108	102	96*	87	74									
700.144	D-CH100-315/308-177,5	130.5	131	130	128	124	120	115	106*	96	84								
700.145	D-L125-200/206-65,3	48	47				38	36	34	32	30*	28	22						
700.146	D-L125-200/216-89,8	66	57				49	47	45	42	40	38*	31	22					
700.147	D-CH125-250/222-89,8	66	59				55	53	50*	47	43								
700.148	D-L125-270/224-133,4	98.1	65				59	56	55	53	50*	48	47	35					
700.149	D-L125-270/237-133,4	98.1	75				70	68	65	65	61	60*	54	45	36				
700.150	D-L125-270/253-177,5	130.5	88				82	80	78	76	74	71	66*	57	46				
700.151	D-CH125-250/264-177,5	130.5	91				90	88	86	84	81	77*	72	62					
700.152	D-L125-270/266-177,5	130.5	97				91	90	87	86	84	81	76*	70	60				
700.153	D-CH125-250/278-200,7	147.6	102				101	100	99	97	95	93	87*	80	71				
700.154	D-S125-315R/302-242	177.3	124				118	117	115	112	109*	105	102	90					
700.155	D-S150-315R/257-242	177.3	70				68	67	66	64	62	58	52*	47	42	35			
700.156	D-S150-315R/266-242	177.3	85				82	81	80	78	76	72	68*	62	56	50			
700.157	D-S150-315R/280-272	199.8	97				94	93	92	90	88	85	80*	75	70	62	53		
700.158	D-S150-315R/290-302	221.4	107				106	105	103	102	101	97	95*	90	85	80	75		

Tolerances in table: ISO 9906 Annex A (performance at the outlet of the pump)  
Gray boxes: NPSH ≥ 5m (possible installation only with positive suction head)  
\* maximum efficiency point

## Dimensions - Fire fighting units Series "D"

Fire fighting units with horizontal pumps back pull-out type  
1 Diesel main motorpump module

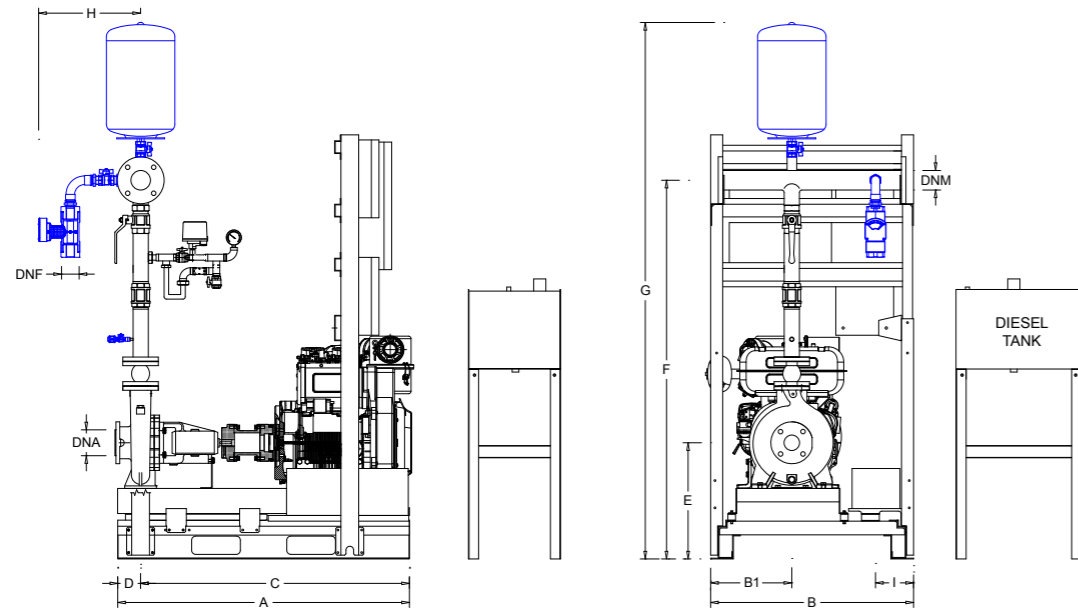

Units with capacity from m³/h 0 up to m³/h 96

Fire Fighting Unit		Flow meter kit	Connections			Dimensions (mm)										Diesel Tank model															
Code	Model		DNA	DNM	DNF	A	B	B1	C	D	E	F	G	H	I																
700.080	D-L32-200/188-5,8	KA-32-32	DN50	DN65	1 1/4"	1150	800	305	1060	90	438	1428*	2050*	405*	150	TK1															
700.081	D-L32-200/204-5,8																														
700.082	D-S32-200N/206-8,4																														
700.083	D-S32-200N/219-14,4																														
700.084	D-L32X-250/256-14,4																														
700.085	D-C32-250/225-18,5																														
700.086	D-C32-250/235-24																														
700.087	D-C32-250/255-24																														
700.088	D-C32-250/264-27																KA-40-40	DN65	DN65	1 1/2"	1480	800	305	1360	90	458	1493*	2115*	405*	150	TK2
700.089	D-S40-200/190-8,4																														
700.090	D-L40-200/209-14,4	KA-40-40	DN65	DN65	1 1/2"	1150	800	305	1160	90	438	1428*	2050*	405*	150	TK1															
700.091	D-S40-200/212-14,4																														
700.092	D-L40-250/233-18,5																														
700.093	D-L40-250/251-24																														
700.094	D-S40-250N/240-27																														
700.095	D-S40-250N/255-36																KA-50-50	DN65	DN65	2"	1480	800	305	1360	90	498	1533*	2155*	405*	150	TK2
700.096	D-S40-250N/259-36																														
700.097	D-L50-200/197-14,4																KA-50-50	DN65	DN80	2"	1480	800	305	1060	90	438	1503	2125	405*	150	TK1
700.098	D-L50-200/209-18,5																														
700.099	D-L50-250/224-24																														
700.100	D-L50-250/237-27																														
700.101	D-L50-250/250-36	KB1-65-65	DN65	DN65	1480	800	305	1360	90	498	1563	2185	432	150	TK2																
700.102	D-C50-250/255-42,6																														
700.103	D-C50-250/264-42,6	KA-50-50	DN65	DN80	2"	1900	900	345	1650	250	515	1605	2232	405*	150	TK3															
700.104	D-CH50-315/291-65,3																														
700.105	D-CH50-315/308-89,8	KB1-65-65	DN65	DN65	1900	900	365	1650	250	520	1665	2292	432	150	TK4																

\* Tolerance of ± 50 mm  
blue components: optional available on request

Dimensions of fuel tanks on p. 61

## Dimensions - Fire fighting units Series "D"

Fire fighting units with horizontal pumps back pull-out type  
1 Diesel main motorpump module

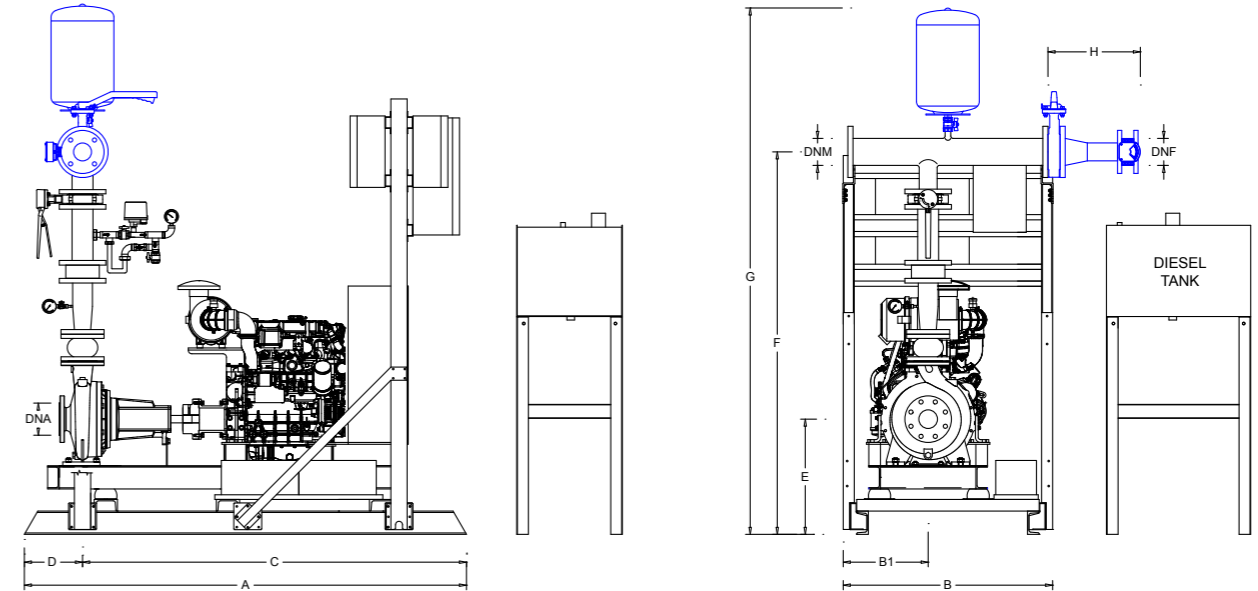

Units with capacity from m³/h 66 up to m³/h 360

Fire Fighting Unit		Flow meter kit	Connections			Dimension (mm)										Diesel Tank model
Code	Model		DNA	DNM	DNF	A	B	B1	C	D	E	F	G	H		
700.106	D-L65-200/187-24	KB2-100-65	DN65	DN80	1330	800	320	1060	90	458	1581	2216	397	TK2		
700.107	D-S65-200N/192-36															
700.108	D-L65-200/198-27	KB2-100-65	DN65	DN80	1480	800	305	1360	90	458	1581	2216	397	TK2		
700.109	D-L65-200/210-36															
700.110	D-S65-200N/215-42,6	KB2-100-80	DN80	DN100	1900	900	365	1650	250	495	1644	2262	397	TK3		
700.111	D-L65-250/241-42,6															
700.112	D-L65-250/258-50	KB2-100-65	DN80	DN100	1900	900	365	1650	250	495	1644	2262	397	TK3		
700.113	D-S65-250N/222-42,6															
700.114	D-S65-250N/245-65,3	KB2-100-80	DN80	DN100	2000	900	365	1750	250	520	1699	2317	402	TK4		
700.115	D-S65-250N/255-65,3															
700.116	D-S65-250N/259-65,3	KB2-100-80	DN80	DN100	2000	900	365	1750	250	520	1699	2317	402	TK5		
700.117	D-S65-315R/273-89,8															
700.118	D-S65-315R/282-89,8	KB2-125-80	DN80	DN100	1505	800	305	1360	90	492	1684	2315	426	TK3		
700.119	D-L80-200/189-36															
700.120	D-L80-200/207-42,5	KC-125-100	DN100	DN125	1900	900	365	1650	250	475	1667	2298	420	TK3		
700.121	D-L80-250/225-50															
700.122	D-L80-250/238-65,3	KB2-125-80	DN80	DN100	1900	900	365	1650	250	495	1717	2348	426	TK4		
700.123	D-L80-250/256-89,8															
700.124	D-L80X-250/270-133,4	KC-125-100	DN100	DN125	2350	1250	495	2190	160	610	1832	2463	420	TK5		
700.125	D-C80-200/205-65,3															
700.126	D-C80-200/214-65,3	KC-125-100	DN100	DN100	1900	900	365	1650	250	475	1667	2298	420	TK4		
700.127	D-C80-250/235-65,3															
700.128	D-C80-250/255-89,8	KC-125-100	DN100	DN100	2350	1250	495	2190	160	610	1832	2463	420	TK5		
700.129	D-C80-250/264-133,4															
700.130	D-S80-250/269-177,5	KC-125-100	DN100	DN100	2350	1250	495	2190	160	635	1857	2488	420	TK6		
700.131	D-S80-315R/302-177,5															

\* Tolerance of ± 50 mm  
blue components: optional available on request

Dimensions of fuel tanks on p. 61



# 3.3

Fire fighting units with horizontal pumps back pull-out type, made according to standard EN 12845

1 Electric main pump + 1 jockey pump  
**“EP” Series**

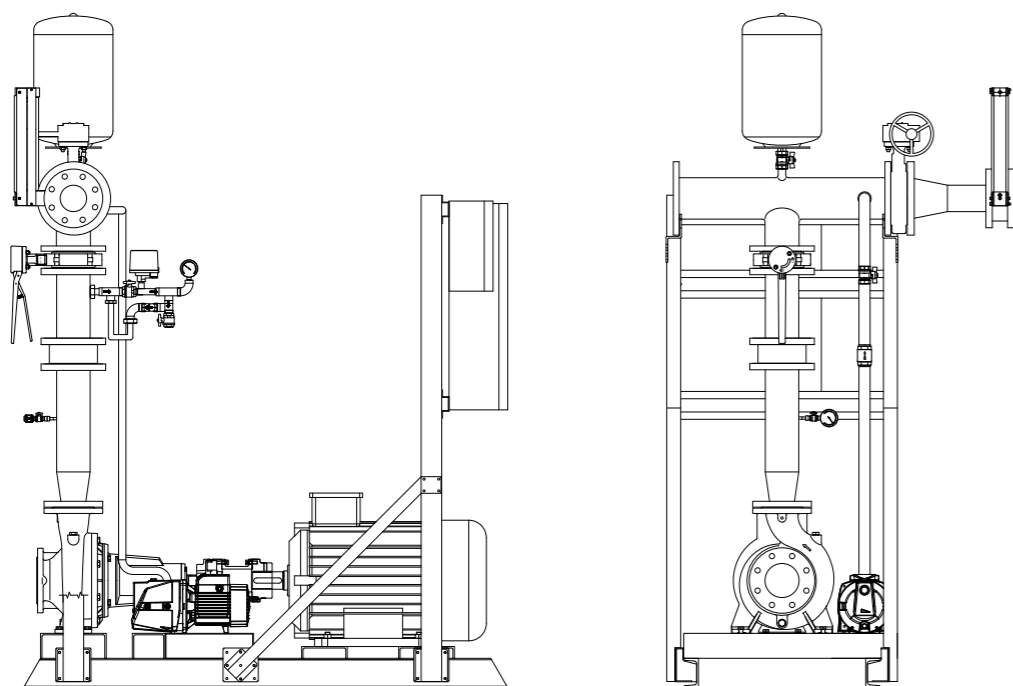

Fire fighting unit according to standard EN 12845, consists of 1 electric main pump + 1 jockey pump:

Main centrifugal pump “back pull-out” according to EN 733 (formerly DIN 24255) axial suction and radial discharge, cast iron pump casing, mechanical seal, coupling performed by means of flexible coupling spacer with three-phase asynchronous electric motor. The fire fighting unit is complete with an electric main pump and a jockey pump mounted on a painted steel base, electrically wired to the electrical control panels installed on board skid (for power ≥ kW 160, the electric panel of the main pump is supplied loose cabinet metal

size = WxHxD mm 800x1800x430 and its wiring with the group will be at the customer). The standard supply of the Fire unit Series “EP” does not include either the suction valve or suction eccentric enlargement of the main pump, which must be ordered separately (suction reducing eccentric be sized according to the directions of the standard EN 12845).

Fire fighting units with horizontal pumps back pull-out type, made according to standard EN 12845

1 Electric main pump + 1 jockey pump  
**“EP” Series**

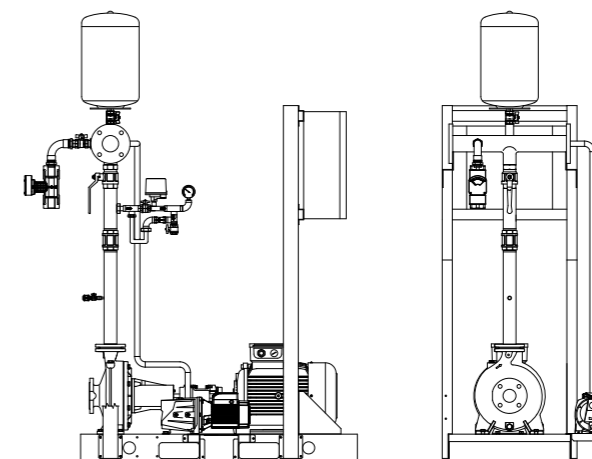

Units with capacity from m³/h 0 up to m³/h 96

Code	Model	Electric Power (kW)	Q= CAPACITY OF EACH SERVICE PUMP																		
			m³/h 0	7,2	9	14,4	18	21,6	24	27	28,8	30	36	43,2	50,4	54	60	72	84	90	96
			l/m 0	120	150	240	300	360	400	450	480	500	600	720	840	900	1000	1200	1400	1500	1600
H= Total head ( m.c.a. )																					
700.159	EP-L32-200/188-4	3+1.1	44	41	40	35	32*	27	24	20											
700.160	EP-L32-200/204-5,5	4+1.1	54	51	45	45	42	37*	34	30	27	26									
700.161	EP-S32-200N/206-7,5	5.5+1.1	54			51	49	46	44*	40	36	35									
700.162	EP-S32-200N/219-10	7.5+1.1	63			62	61	60	57*	54	52	50	36								
700.163	EP-L32X-250/256-15	11+2.2	86			74	71	66*	63	59											
700.164	EP-C32-250/225-20	15+2.2	69				69	68	67	65	63	62*	53								
700.165	EP-C32-250/235-20	15+2.2	77				76	75	74	73	71	70*	61								
700.166	EP-C32-250/255-25	18.5+2.2	89				89	88	87	85	84	83	75*	60							
700.167	EP-C32-250/264-25	18.5+2.2	96				95	94	92	91	89	88	80*	64							
700.168	EP-S40-200/190-10	7.5+1.1	46				44	43	41	40	39	38*	33	26	20						
700.169	EP-L40-200/209-10	7.5+1.1	57				54	52	51	50	49	48	46*	41							
700.170	EP-S40-200/212-12,5	9.2+1.1	58				58	56	55	54	53	52	47*	41	35						
700.171	EP-L40-250/233-15	11+2.2	72				68	65	64	63	62	61	57	52*	44						
700.172	EP-L40-250/251-20	15+2.2	85				80	78	77	75	74	73	70	65*	56	53					
700.173	EP-S40-250N/240-25	18.5+2.2	81					79	78	77	76	75	69	68*	65	61	51				
700.174	EP-S40-250N/255-30	22+2.2	95					89	88	87	86	84	80	76*	74	69	55				
700.175	EP-S40-250N/259-40	30+2.2	98					92	91	91,5	90	87	81	79*	76	71	59				
700.176	EP-L50-200/197-15	11+1.1	51									48	47	45	42	41	38*	33	26		
700.177	EP-L50-200/209-15	11+1.1	58									55	54	53	50	49	43*	40	33	29	
700.178	EP-L50-250/224-20	15+2.2	68										64	63	60	59	56*	50	41		
700.179	EP-L50-250/237-25	18.5+2.2	77										73	72	70	68	66	60*	52	47	
700.180	EP-L50-250/250-30	22+2.2	86										83	81	79	78	75	70*	61	57	52
700.181	EP-C50-250/255-40	30+2.2	95										92	90,5	88	86	83*	72	50	36	
700.182	EP-C50-250/264-50	37+2.2	104										101	99	96	94	91	83*	61	54	26
700.183	EP-CH50-315/291-75	55+3	118										114	113	110	108	106	98*	82	74	
700.184	EP-CH50-315/308-100	75+4	132										129	127	125	123	122	116	106*	100	90

Tolerances in table: ISO 9906 Annex A (performance at the outlet of the pump)  
 Gray boxes: NPSH ≥ 5m (possible installation only with positive suction head)  
 \* maximum efficiency point

Fire fighting units with horizontal pumps back pull-out type, made according to standard EN 12845

**1 Electric main pump + 1 jockey pump**  
**“EP” Series**

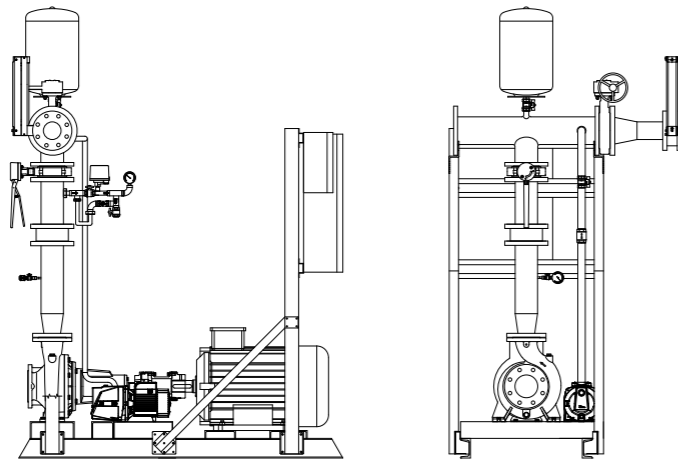

Units with capacity from m³/h 66 up to m³/h 360

Code	Model	Electric Power (kW)	Q= CAPACITY OF EACH SERVICE PUMP															
			m³/h 0	66	72	90	108	120	150	180	210	240	270	300	330	360		
			l/m 0	1100	1200	1500	1800	2000	2500	3000	3500	4000	4500	5000	5500	6000		
H= Total head ( m.c.a. )																		
700.185	EP-L65-200/187-20	15+1.1	45	44	43	40*	37	34										
700.186	EP-S65-200N/192-30	22+1.1	50	50	48	46*	43	40	30	15								
700.187	EP-L65-200/198-25	18.5+1.1	52	51	51	48	45*	42										
700.188	EP-L65-200/210-30	22+1.1	59	59	58	55	52*	50										
700.189	EP-S65-200N/215-40	30+2.2	65	64	64	61	58*	55	46	34								
700.190	EP-L65-250/241-40	30+2.2	76	74	73	69	64*	61										
700.191	EP-L65-250/258-50	37+2.2	90	87	86	83	78*	75										
700.192	EP-S65-250N/222-40	30+2.2	70	68	67	65	62*	59	51									
700.193	EP-S65-250N/245-60	45+2.2	83	82	82	79	76	73*	65									
700.194	EP-S65-250N/255-60	45+2.2	92	92	91	89	85	83*	74	65								
700.195	EP-S65-250N/259-75	55+2.2	95	94	93	92	88	85*	76	69								
700.196	EP-S65-315R/273-75	55+2.2	101	100	99	96	93*	90	84									
700.197	EP-S65-315R/282-100	75+3	112	111	110	108	105*	103	96	87								
700.198	EP-L80-200/189-30	22+1.1	48				45	44	38*	32								
700.199	EP-L80-200/207-40	30+1.1	60				58	57	52*	46	40							
700.200	EP-L80-250/225-50	37+2.2	71				67	65	58*	49								
700.201	EP-L80-250/238-60	45+2.2	80				78	76	70*	62								
700.202	EP-L80-250/256-75	55+2.2	92				91	90	84	76*	68							
700.203	EP-L80X-250/270-100	75+3	112				108	106	101	94*	83							
700.204	EP-C80-200/205-60	45+1.1	58					56	53	50*	46	42						
700.205	EP-C80-200/214-75	55+1.1	64					62	60	57	53*	49						
700.206	EP-C80-250/235-75	55+2.2	75					70	68	64*	57	44	30					
700.207	EP-C80-250/255-100	75+2.2	89					85	84	80	75*	68	56	38				
700.208	EP-C80-250/264-100	75+2.2	106					90	89	87	83*	76	66	52				
700.209	EP-S80-250/269-150	110+2.2	102					102	100	98	95	92*	88	85	82	77		
700.210	EP-S80-315R/302-150	110+3	117					115	113	112	108*	103	90					

Tolerances in table: ISO 9906 Annex A (performance at the outlet of the pump)  
Gray boxes: NPSH ≥ 5m (possible installation only with positive suction head)  
\* maximum efficiency point

Fire fighting units with horizontal pumps back pull-out type, made according to standard EN 12845

**1 Electric main pump + 1 jockey pump**  
**“EP” Series**

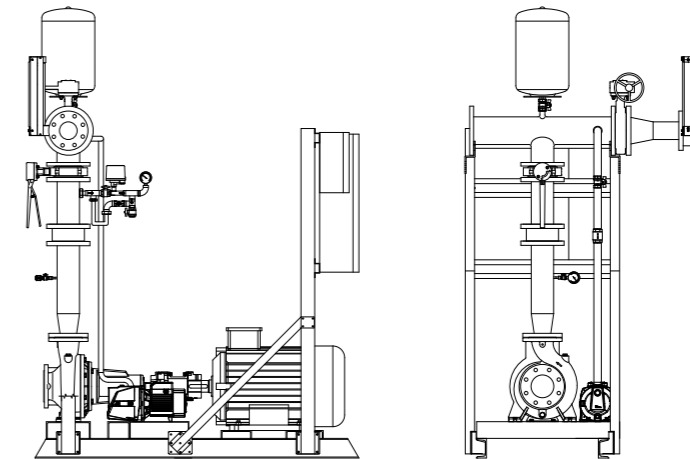

Units with capacity from m³/h 150 up to m³/h 750

Code	Model	Electric Power (kW)	Q= CAPACITY OF EACH SERVICE PUMP																		
			m³/h 0	150	180	210	240	270	300	330	360	390	420	480	540	600	650	700	750		
			l/m 0	2500	3000	3500	4000	4500	5000	5500	6000	6500	7000	8000	9000	10000	10833	11667	12500		
H= Total head ( m.c.a. )																					
700.211	EP-L100-200/192-40	30+1.1	49	45	42	38*	34	30	24												
700.212	EP-L100-200/203-50	37+1.1	56	52	50	46	42*	38	33	26											
700.213	EP-L100-250/221-60	45+2.2	69	65	59	56*	50	45	35												
700.214	EP-L100-250/235-75	55+2.2	79	75	72	69	64*	56	50												
700.215	EP-L100-250/254-100	75+2.2	92	89	86	84	80	75*	67												
700.216	EP-L100-250/267-125	90+2.2	103	100	98	95	90	85*	80												
700.217	EP-S100-200/219-75	55+1.1	62,5	60	59	57,5	55	52,5	49*	43	37,5										
700.218	EP-S100-250/233-100	75+2.2	68	67	64	61	57	55*	49	43	30										
700.219	EP-S100-250/250-100	75+2.2	80	79	77	75	72	69	64*	59	53										
700.220	EP-S100-250/265-125	90+2.2	95	92	90	88	86	84	80*	75	70										
700.221	EP-S100-250/269-150	110+2.2	97	95	94	92	90	86	83*	78	74										
700.222	EP-CH100-315/291-150	110+3	117	114	111	108	102	96*	87	74											
700.223	EP-CH100-315/308-180	132+4	131	130	128	124	120	115	106*	96	84										
700.224	EP-L125-200/206-60	45+1.1	47					38	36	34	32	30*	28	22							
700.225	EP-L125-200/216-75	55+1.1	57					49	47	45	42	40	38*	31	22						
700.226	EP-CH125-250/222-100	75+1.1	59					55	53	50*	47	43									
700.227	EP-L125-270/224-100	75+2.2	65					59	56	55	53	50*	48	47	35						
700.228	EP-L125-270/237-125	90+2.2	75					70	68	65	65	61	60*	54	45	36					
700.229	EP-L125-270/253-150	110+2.2	88					82	80	78	76	74	71	66*	57	46					
700.230	EP-CH125-250/264-180	132+2.2	91					90	88	86	84	81	77*	72	62						
700.231	EP-L125-270/266-180	132+2.2	97					91	90	87	86	84	81	76*	70	60					
700.232	EP-CH125-250/278-218	160+2.2	102					101	100	99	97	95	93	87*	80	71					
700.233	EP-S125-315R/302-272	200+3	124						118	117	115	112	109*	105	102	90					
700.234	EP-S150-315R/257-218	160+2.2	70							68	67	66	64	62	58	52*	47	42	35		
700.235	EP-S150-315R/266-218	160+2.2	85							82	81	80	78	76	72	68*	62	56	50		
700.236	EP-S150-315R/280-272	200+2.2	97							94	93	92	90	88	85	80*	75	70	62	53	
700.237	EP-S150-315R/290-340	250+2.2	107								106	105	103	102	101	97	95*	90	85	80	75

Tolerances in table: ISO 9906 Annex A (performance at the outlet of the pump)  
Gray boxes: NPSH ≥ 5m (possible installation only with positive suction head)  
\* maximum efficiency point

## Dimensions - Fire fighting units Series "EP"

Fire fighting units with horizontal pumps back pull-out type  
1 Electric main pump + 1 jockey pump

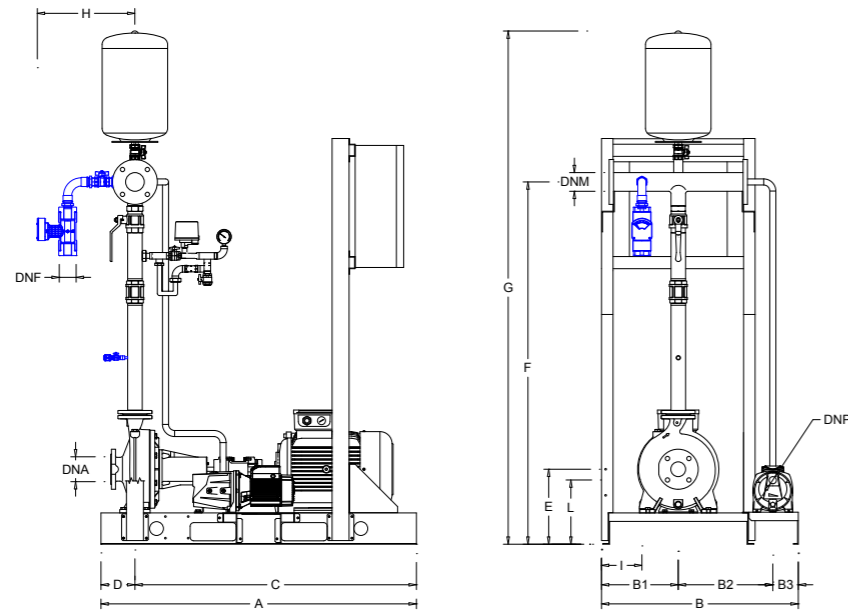

Units with capacity from m<sup>3</sup>/h 0 up to m<sup>3</sup>/h 96

Code	Fire Fighting Unit Model	Flow meter kit	Jockey pump	Connections				Dimensions (mm)													
				DNA	DNM	DNF	DNP	A	B	B1	B2	B3	C	D	E	F	G	H	I	L	
700.159	EP-L32-200/188-4																				
700.160	EP-L32-200/204-5,5		J1				1"							290	1428*	2050*				280	
700.161	EP-S32-200/206-7,5																				
700.162	EP-S32-200N/219-10	KA-32-32				1 1/4"															
700.163	EP-L32X-250/256-15		J3	DN50	DN65			1300	811	316	390	105	1160	140		1533*	2155*		405*	150	172
700.164	EP-C32-250/225-20		J2																		297
700.165	EP-C32-250/235-20															309	1493*	2115*			
700.166	EP-C32-250/255-25	KA-40-40	J3				1 1/2"														172
700.167	EP-C32-250/264-25															1527*	2150*				
700.168	EP-S40-200/190-10		J1												290	1428*	2050*				279
700.169	EP-L40-200/209-10																				
700.170	EP-S40-200/212-12,5	KA-40-40	J2				1 1/2"														
700.171	EP-L40-250/233-15		J3	DN65	DN65			1300	811	316	390	105	1160	140		1533*	2155*		405*	150	297
700.172	EP-L40-250/251-20															1493*	2115*				172
700.173	EP-S40-250N/240-25		J2												309						297
700.174	EP-S40-250N/255-30	KA-50-50	J3				2"									1527*	2150*				172
700.175	EP-S40-250N/259-40														330						
700.176	EP-L50-200/197-15	KA-50-50	J1				2"								290	1503	2125	405*			279
700.177	EP-L50-200/209-15	KB1-65-65					DN65									1563	2185	432			
700.178	EP-L50-250/224-20	KA-50-50	J2					1300	811	316	390	105	1160	140		1548	2170	405*			297
700.179	EP-L50-250/237-25	KB1-65-65													309	1582	2187	432			
700.180	EP-L50-250/250-30	KB1-65-65	J1	DN65	DN80																150
700.181	EP-C50-250/255-40	KA-50-50	J3				2"								1650				405*		205
700.182	EP-C50-250/264-50																				
700.183	EP-CH50-315/291-75	KB1-65-65	J4				DN65								1800	786	393	281	112		170
700.184	EP-CH50-315/308-100		J5												1900						235

\* Tolerance of ± 50 mm  
blue components: optional available on request

## Dimensions - Fire fighting units Series "EP"

Fire fighting units with horizontal pumps back pull-out type  
1 Electric main pump + 1 jockey pump

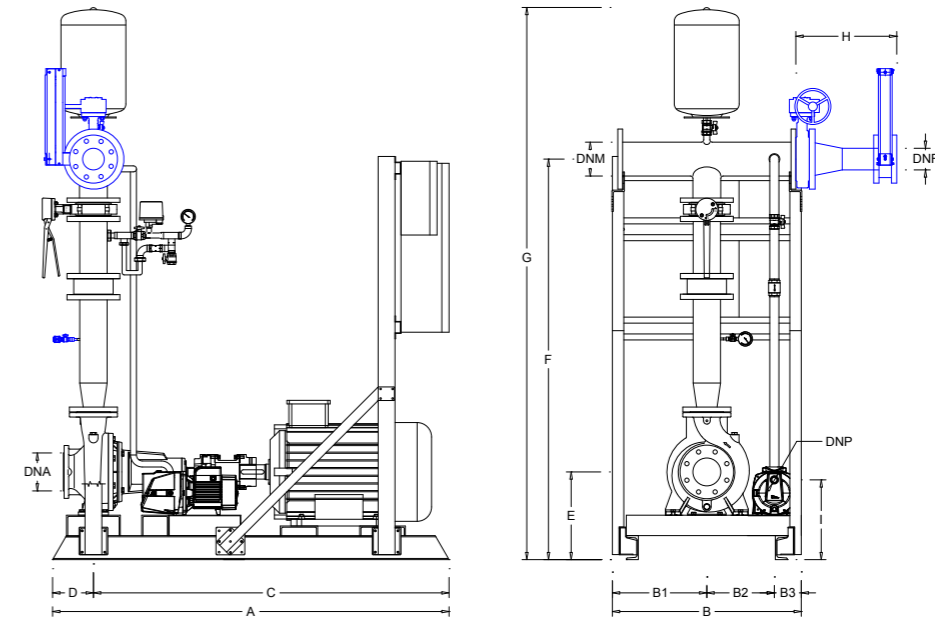

Units with capacity from m<sup>3</sup>/h 66 up to m<sup>3</sup>/h 360

Code	Fire Fighting Unit Model	Flow meter kit	Jockey pump	Connections				Dimensions (mm)														
				DNA	DNM	DNF	DNP	A	B	B1	B2	B3	C	D	E	F	G	H	I			
700.185	EP-L65-200/187-20	KB2-100-65																				
700.186	EP-S65-200N/192-30	KB2-100-80	J1																			
700.187	EP-L65-200/198-25																					
700.188	EP-L65-200/210-30	KB2-100-65																				
700.189	EP-S65-200N/215-40	KB2-100-80	J2																			
700.190	EP-L65-250/241-40																					
700.191	EP-L65-250/258-50	KB2-100-65	J3	DN80	DN100																	
700.192	EP-S65-250N/222-40																					
700.193	EP-S65-250N/245-60		J2																			
700.194	EP-S65-250N/255-60																					
700.195	EP-S65-250N/259-75	KB2-100-80	J3																			
700.196	EP-S65-315R/273-75																					
700.197	EP-S65-315R/282-100		J4																			
700.198	EP-L80-200/189-30	KB2-125-80	J1																			
700.199	EP-L80-200/207-40	KC-125-100																				
700.200	EP-L80-250/225-50																					
700.201	EP-L80-250/238-60	KB2-125-80	J2																			
700.202	EP-L80-250/256-75		J3																			
700.203	EP-L80X-250/270-100		J4																			
700.204	EP-C80-200/205-60																					
700.205	EP-C80-200/214-75		J1	DN100	DN125																	
700.206	EP-C80-250/235-75																					
700.207	EP-C80-250/255-100	KC-125-100	J2																			
700.208	EP-C80-250/264-100		J3																			
700.209	EP-S80-250/269-150																					
700.210	EP-S80-315R/302-150		J4																			

\* Tolerance of ± 50 mm  
blue components: optional available on request

# Dimensions - Fire fighting units Series "EP"

Fire fighting units with horizontal pumps back pull-out type  
**1 Electric main pump + 1 jockey pump**

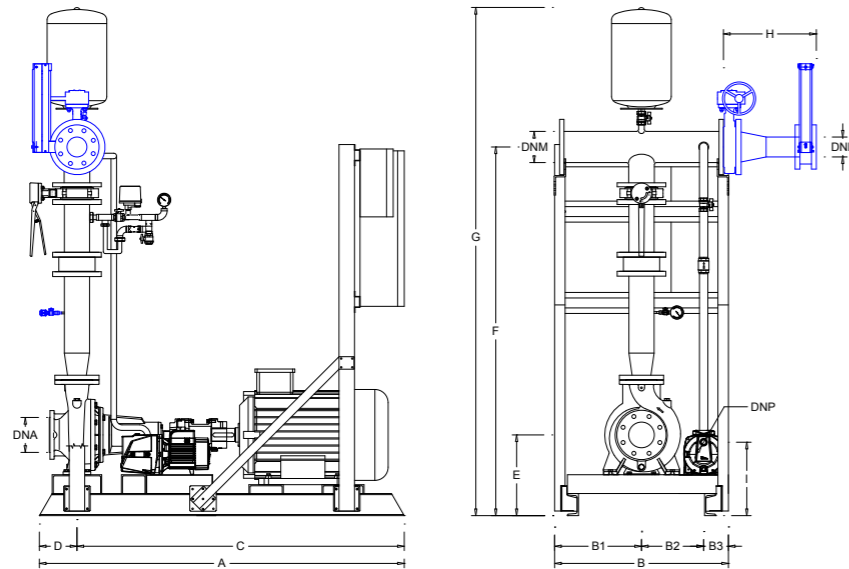

Units with capacity from m³/h 150 up to m³/h 750

Fire Fighting Unit		Flow meter kit	Jockey pump	Connections				Dimensions (mm)																	
Code	Model			DNA	DNM	DNF	DNP	A	B	B1	B2	B3	C	D	E	F	G	H	I						
700.211	EP-L100-200/192-40	KC-150-125	J1	DN125	DN150	DN125	1"	1650	786	393	281	112	1480	170	340	1776	2421	472	287						
700.212	EP-L100-200/203-50		J2				1 1/4"								365	1801	2446		305						
700.213	EP-L100-250/221-60		J3				420								1881	2526	235								
700.214	EP-L100-250/235-75		J1				1"								390	1776	2421		337						
700.215	EP-L100-250/254-100		J2				1 1/4"								420	1801	2446		360						
700.216	EP-L100-250/267-125		J3				1881								2526	235									
700.217	EP-S100-200/219-75		J4				2150								1046	523	411		112	1965	185	475	1881	2526	315
700.218	EP-S100-250/233-100		J5				2150								1046	523	411		112	1965	185	475	1941	2586	265
700.219	EP-S100-250/250-100		J1				1"								390	1776	2421		337						
700.220	EP-S100-250/265-125		J2				1 1/4"								420	1801	2446		360						
700.221	EP-S100-250/269-150	J3	1881	2526	235																				
700.222	EP-CH100-315/291-150	KC-200-150	J4	DN150	DN200	DN150	1"	1800	786	393	281	1630	170	390	1957	2652	536	287							
700.223	EP-CH100-315/308-180		J1				1 1/4"							420	2077	2772		305							
700.224	EP-L125-200/206-60		J2				2117							2792	438										
700.225	EP-L125-200/216-75		J3				2150							1046	523	411		112	1965	185	475	2077	2772	536	273
700.226	EP-CH125-250/222-100		J4				2200							2015	506	2107		2802	536	265					
700.227	EP-L125-270/224-100		J5				2200							1046	523	411		112	2015	185	505	2290	2992	636	265
700.228	EP-L125-270/237-125		J1				1"							390	1776	2421		337							
700.229	EP-L125-270/253-150		J2				1 1/4"							420	1801	2446		360							
700.230	EP-CH125-250/264-180		J3				1881							2526	235										
700.231	EP-L125-270/266-180		J4				2150							1046	523	411		112	1965	185	475	2077	2772	536	273
700.232	EP-CH125-250/278-218	J5	2200	2015	506	2107	2802	536	265																
700.233	EP-S125-315R/302-272	KC-250-200	J2	DN200	DN250	DN200	1 1/4"	2200	1046	523	411	112	2015	185	505	2290	2992	636	265						
700.234	EP-S150-315R/257-218		J3				390																		
700.235	EP-S150-315R/266-218		J4				438																		
700.236	EP-S150-315R/280-272		J5				536																		
700.237	EP-S150-315R/290-340	J1	1"	390	1776	2421	337																		

\* Tolerance of ± 50 mm  
 blue components: optional available on request

## Note

The technical data contained in this catalog shall be considered binding and can be changed without notice, the figures are illustrative representations and are not binding. We reserve the right to make changes without prior notice.

# 3.4

Fire fighting units with horizontal pumps back pull-out type, made according to standard EN 12845

**1 Diesel main motorpump + 1 jockey pump**  
**“DP” Series**

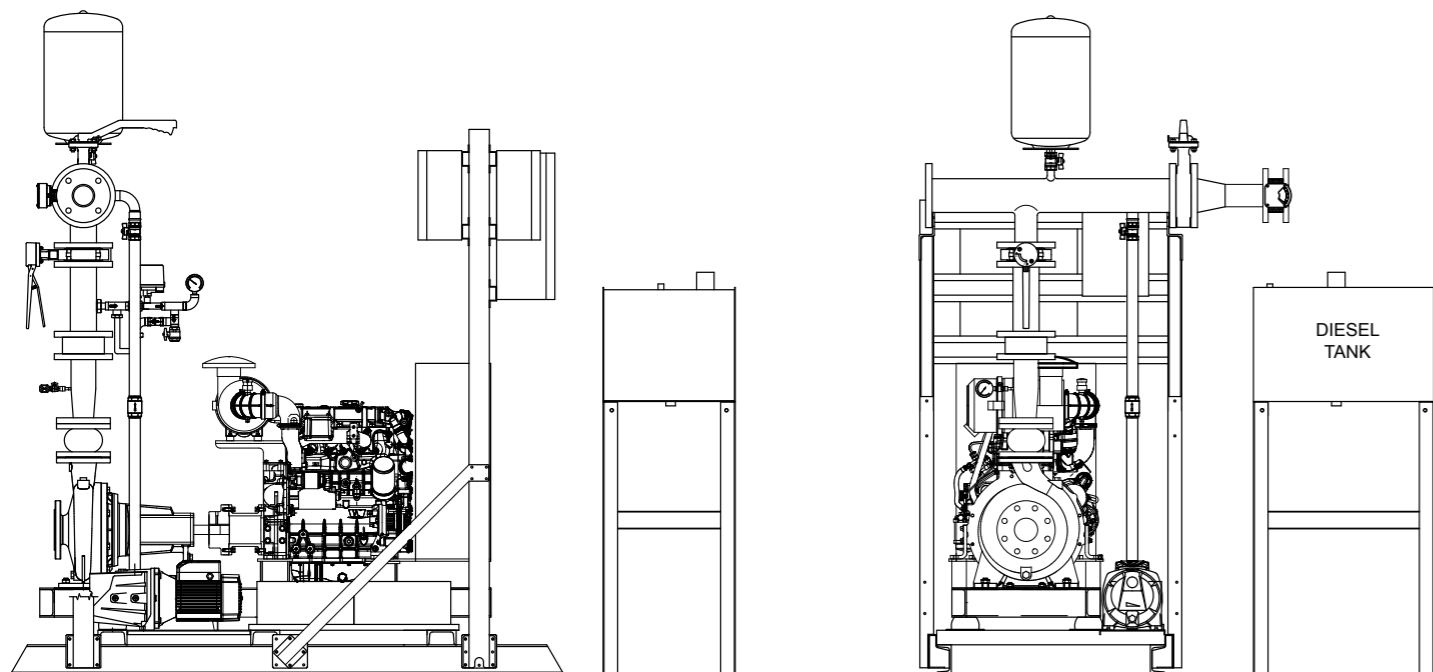

Fire fighting unit according to standard EN 12845, consists of 1 diesel main pump + 1 jockey pump:

Main centrifugal pump “back pull-out” according to EN 733 (formerly DIN 24255) axial suction and radial discharge, cast iron pump casing, mechanical seal, coupling performed by means of flexible coupling spacer with diesel engine fitted in compliance with EN 12845. The fire fighting unit is complete with a diesel main pump and a jockey pump mounted on a painted steel base, electrically wired to the electrical control panels installed on board skid. The standard supply of the Fire unit series “DP” does not include either

the suction valve or suction eccentric enlargement of the main pump or elastic vibration compensator, which must be ordered separately (suction reducing eccentric be sized according to the directions of the standard EN 12845). Diesel tank included, provided on a separate pedestal.

Fire fighting units with horizontal pumps back pull-out type, made according to standard EN 12845

**1 Diesel main motorpump + 1 jockey pump**  
**“DP” Series**

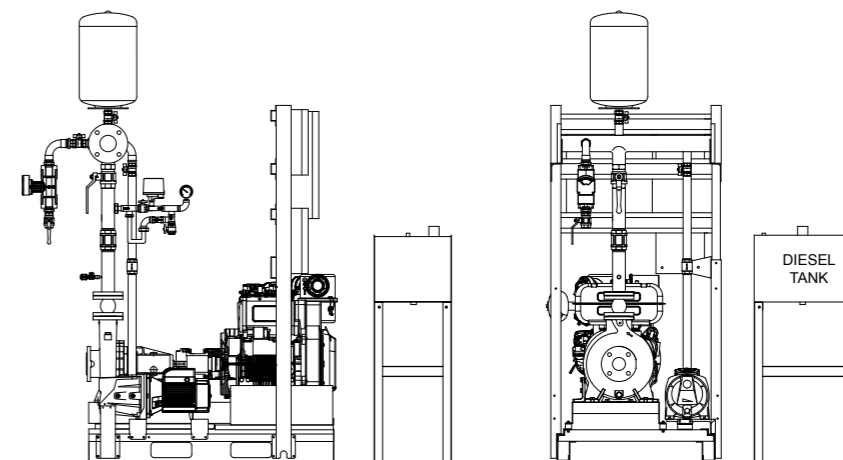

Units with capacity from m³/h 0 up to m³/h 96

Code	Model	Electric Power (kW)	Q= CAPACITY OF EACH SERVICE PUMP																		
			m³/h 0	7,2	9	14,4	18	21,6	24	27	28,8	30	36	43,2	50,4	54	60	72	84	90	96
			l/m 0	120	150	240	300	360	400	450	480	500	600	720	840	900	1000	1200	1400	1500	1600
			H= Total head ( m.c.a. )																		
700.238	DP-L32-200/188-5,8	1.1	44	41	40	35	32*	27	24	20											
700.239	DP-L32-200/204-5,8	1.1	54	51	45	45	42	37*	34	30	27	26									
700.240	DP-S32-200N/206-8,4	1.1	54			51	49	46	44*	40	36	35									
700.241	DP-S32-200N/219-14,4	1.1	63			62	61	60	57*	54	52	50	36								
700.242	DP-L32X-250/256-14,4	2.2	86			74	71	66*	63	59											
700.243	DP-C32-250/225-18,5	2.2	69				69	68	67	65	63	62*	53								
700.244	DP-C32-250/235-24	2.2	77				76	75	74	73	71	70*	61								
700.245	DP-C32-250/255-24	2.2	89				89	88	87	85	84	83	75*	60							
700.246	DP-C32-250/264-27	2.2	96				95	94	92	91	89	88	80*	64							
700.247	DP-S40-200/190-8,4	1.1	46				44	43	41	40	39	38*	33	26	20						
700.248	DP-L40-200/209-14,4	1.1	57				54	52	51	50	49	48	46*	41							
700.249	DP-S40-200/212-14,4	1.1	58				58	56	55	54	53	52	47*	41	35						
700.250	DP-L40-250/233-18,5	2.2	72				68	65	64	63	62	61	57	52*	44						
700.251	DP-L40-250/251-24	2.2	85				80	78	77	75	74	73	70	65*	56	53					
700.252	DP-S40-250N/240-27	2.2	81					79	78	77	76	75	69	68*	65	61	51				
700.253	DP-S40-250N/255-36	2.2	95					89	88	87	86	84	80	76*	74	69	55				
700.254	DP-S40-250N/259-36	2.2	98					92	91	91,5	90	87	81	79*	76	71	59				
700.255	DP-L50-200/197-14,4	1.1	51									48	47	45	42	41	38*	33	26		
700.256	DP-L50-200/209-18,5	1.1	58									55	54	53	50	49	43*	40	33	29	
700.257	DP-L50-250/224-24	2.2	68									64	63	60	59	56*	50	41			
700.258	DP-L50-250/237-27	2.2	77									73	72	70	68	66	60*	52	47		
700.259	DP-L50-250/250-36	2.2	86									83	81	79	78	75	70*	61	57	52	
700.260	DP-C50-250/255-42,6	2.2	95									92	90,5	88	86	83*	72	50	36		
700.261	DP-C50-250/264-42,6	2.2	104									101	99	96	94	91	83*	61	54	26	
700.262	DP-CH50-315/291-65,3	3	118									114	113	110	108	106	98*	82	74		
700.263	DP-CH50-315/308-89,8	4	132									129	127	125	123	122	116	106*	100	90	

Tolerances in table: ISO 9906 Annex A (performance at the outlet of the pump)  
 Gray boxes: NPSH ≥ 5m (possible installation only with positive suction head)  
 \* maximum efficiency point

## Fire fighting units with horizontal pumps back pull-out type, made according to standard EN 12845

### 1 Diesel main motorpump + 1 jockey pump "DP" Series

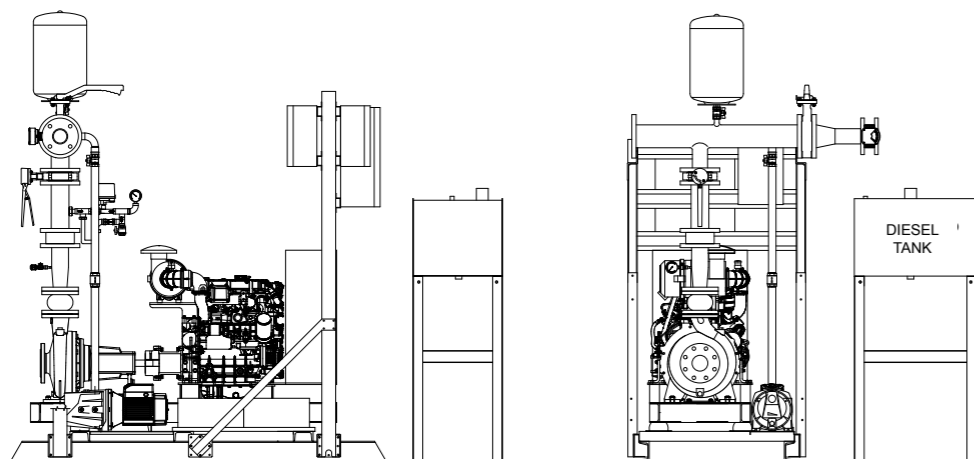

Units with capacity from m<sup>3</sup>/h 66 up to m<sup>3</sup>/h 360

Code	Model	Electric Power (kW)	Q= CAPACITY OF EACH SERVICE PUMP															
			m <sup>3</sup> /h 0	66	72	90	108	120	150	180	210	240	270	300	330	360		
			l/m 0	1100	1200	1500	1800	2000	2500	3000	3500	4000	4500	5000	5500	6000		
H= Total head ( m.c.a. )																		
700.264	DP-L65-200/187-24	1.1	45	44	43	40*	37	34										
700.265	DP-S65-200N/192-36	1.1	50	50	48	46*	43	40	30	15								
700.266	DP-L65-200/198-27	1.1	52	51	51	48	45*	42										
700.267	DP-L65-200/210-36	1.1	59	59	58	55	52*	50										
700.268	DP-S65-200N/215-42,6	2.2	65	64	64	61	58*	55	46	34								
700.269	DP-L65-250/241-42,6	2.2	76	74	73	69	64*	61										
700.270	DP-L65-250/258-50	2.2	90	87	86	83	78*	75										
700.271	DP-S65-250N/222-42,6	2.2	70	68	67	65	62*	59	51									
700.272	DP-S65-250N/245-65,3	2.2	83	82	82	79	76	73*	65									
700.273	DP-S65-250N/255-65,3	2.2	92	92	91	89	85	83*	74	65								
700.274	DP-S65-250N/259-65,3	2.2	95	94	93	92	88	85*	76	69								
700.275	DP-S65-315R/273-89,8	2.2	101	100	99	96	93*	90	84									
700.276	DP-S65-315R/282-89,8	3	112	111	110	108	105*	103	96	87								
700.277	DP-L80-200/189-36	1.1	48				45	44	38*	32								
700.278	DP-L80-200/207-42,5	1.1	60				58	57	52*	46	40							
700.279	DP-L80-250/225-50	2.2	71				67	65	58*	49								
700.280	DP-L80-250/238-65,3	2.2	80				78	76	70*	62								
700.281	DP-L80-250/256-89,8	2.2	92				91	90	84	76*	68							
700.282	DP-L80X-250/270-133,4	3	112				108	106	101	94*	83							
700.283	DP-C80-200/205-65,3	1.1	58					56	53	50*	46	42						
700.284	DP-C80-200/214-65,3	1.1	64					62	60	57	53*	49						
700.285	DP-C80-250/235-65,3	2.2	75					70	68	64*	57	44	30					
700.286	DP-C80-250/255-89,8	2.2	89					85	84	80	75*	68	56	38				
700.287	DP-C80-250/264-133,4	2.2	106					90	89	87	83*	76	66	52				
700.288	DP-S80-250/269-177,5	2.2	102					102	100	98	95	92*	88	85	82	77		
700.289	DP-S80-315R/302-177,5	3	117					115	113	112	108*	103	90					

Tolerances in table: ISO 9906 Annex A (performance at the outlet of the pump)  
Gray boxes: NPSH ≥ 5m (possible installation only with positive suction head)  
\* maximum efficiency point

## Fire fighting units with horizontal pumps back pull-out type, made according to standard EN 12845

### 1 Diesel main motorpump + 1 jockey pump "DP" Series

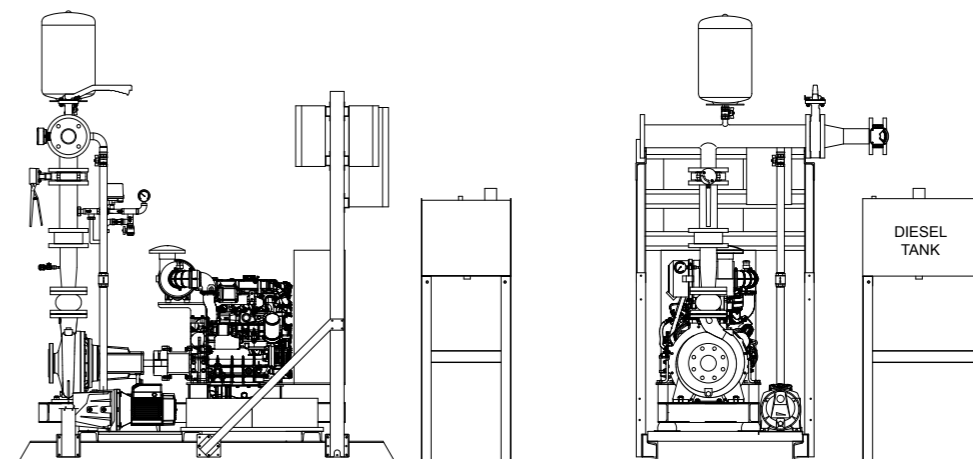

Units with capacity from m<sup>3</sup>/h 150 up to m<sup>3</sup>/h 750

Code	Model	Electric Power (kW)	Q= CAPACITY OF EACH SERVICE PUMP																
			m <sup>3</sup> /h 0	150	180	210	240	270	300	330	360	390	420	480	540	600	650	700	750
			l/m 0	2500	3000	3500	4000	4500	5000	5500	6000	6500	7000	8000	9000	10000	10833	11667	12500
H= Total head ( m.c.a. )																			
700.290	DP-L100-200/192-42,6	1.1	49	45	42	38*	34	30	24										
700.291	DP-L100-200/203-50	1.1	56	52	50	46	42*	38	33	26									
700.292	DP-L100-250/221-65,3	2.2	69	65	59	56*	50	45	35										
700.293	DP-L100-250/235-89,8	2.2	79	75	72	69	64*	56	50										
700.294	DP-L100-250/254-133,4	2.2	92	89	86	84	80	75*	67										
700.295	DP-L100-250/267-133,4	2.2	103	100	98	95	90	85*	80										
700.296	DP-S100-200A/219-89,8	1.1	62,5	60	59	57,5	55	52,5	49*	43	37,5								
700.297	DP-S100-250CD/233-89,8	2.2	68	67	64	61	57	55*	49	43	30								
700.298	DP-S100-250B/250-133,4	2.2	80	79	77	75	72	69	64*	59	53								
700.299	DP-S100-250AB/265-133,4	2.2	95	92	90	88	86	84	80*	75	70								
700.300	DP-S100-250A/269-133,4	2.2	97	95	94	92	90	86	83*	78	74								
700.301	DP-CH100-315/291-177,5	3	117	114	111	108	102	96*	87	74									
700.302	DP-CH100-315/308-177,5	4	131	130	128	124	120	115	106*	96	84								
700.303	DP-L125-200/206-65,3	1.1	47					38	36	34	32	30*	28	22					
700.304	DP-L125-200/216-89,8	1.1	57					49	47	45	42	40	38*	31	22				
700.305	DP-CH125-250/222-89,8	1.1	59					55	53	50*	47	43							
700.306	DP-L125-270/224-133,4	2.2	65					59	56	55	53	50*	48	47	35				
700.307	DP-L125-270/237-133,4	2.2	75					70	68	65	65	61	60*	54	45	36			
700.308	DP-L125-270/253-177,5	2.2	88					82	80	78	76	74	71	66*	57	46			
700.309	DP-CH125-250/264-177,5	2.2	91					90	88	86	84	81	77*	72	62				
700.310	DP-L125-270/266-177,5	2.2	97					91	90	87	86	84	81	76*	70	60			
700.311	DP-CH125-250/278-200,7	2.2	102					101	100	99	97	95	93	87*	80	71			
700.312	DP-S125-315R/302-242	3	124					118	117	115	112	109*	105	102	90				
700.313	DP-S150-315R/257-242	2.2	70						68	67	66	64	62	58	52*	47	42	35	
700.314	DP-S150-315R/266-242	2.2	85						82	81	80	78	76	72	68*	62	56	50	
700.315	DP-S150-315R/280-272	2.2	97						94	93	92	90	88	85	80*	75	70	62	53
700.316	DP-S150-315R/290-302	2.2	107						106	105	103	102	101	97	95*	90	85	80	75

Tolerances in table: ISO 9906 Annex A (performance at the outlet of the pump)  
Gray boxes: NPSH ≥ 5m (possible installation only with positive suction head)  
\* maximum efficiency point

## Dimensions - Fire fighting units Series "DP"

Fire fighting units with horizontal pumps back pull-out type  
1 Diesel main motorpump + 1 jockey pump

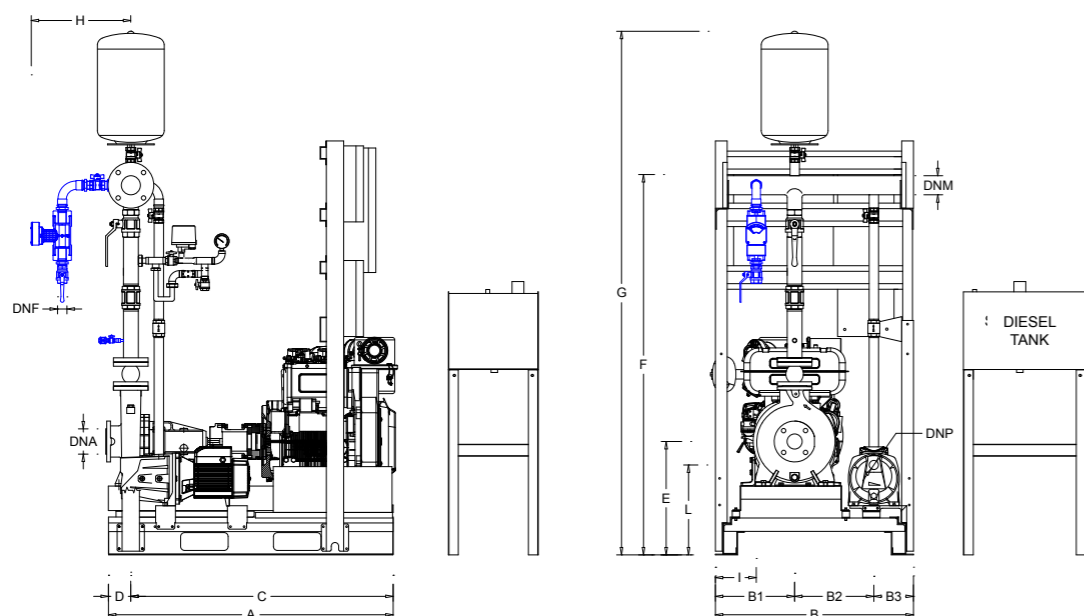

Units with capacity from m<sup>3</sup>/h 0 up to m<sup>3</sup>/h 96

Fire Fighting Unit		Flow meter kit	Jockey pump	Connections				Dimensions (mm)													Diesel Tank model														
Code	Model			DNA	DNM	DNF	DNP	A	B	B1	B2	B3	C	D	E	F	G	H	I	L															
700.238	DP-L32-200/188-5,8	KA-32-32	J1	DN50	DN65	1 1/4"	1150	800	305	335	160	1060	90	438	1428*	2050*	405*	150	346	TK1															
700.239	DP-L32-200/204-5,8													498	1533*	2115*			363																
700.240	DP-S32-200N/206-8,4													498	1533*	2115*			363																
700.241	DP-S32-200N/219-14,4													498	1533*	2115*			363																
700.242	DP-L32X-250/256-14,4													458	1493*	2115*			238																
700.243	DP-C32-250/225-18,5													458	1493*	2115*			238																
700.244	DP-C32-250/235-24													458	1493*	2115*			238																
700.245	DP-C32-250/255-24													458	1493*	2115*			238																
700.246	DP-C32-250/264-27													458	1493*	2115*			238																
700.247	DP-S40-200/190-8,4													KA-40-40	J1	DN65			DN65		1 1/2"	1150	800	305	335	160	1160	90	438	1428*	2050*	405*	150	346	TK1
700.248	DP-L40-200/209-14,4	498	1533*	2155*	364																														
700.249	DP-S40-200/212-14,4	498	1533*	2155*	364																														
700.250	DP-L40-250/233-18,5	498	1533*	2155*	364																														
700.251	DP-L40-250/251-24	498	1533*	2155*	364																														
700.252	DP-S40-250N/240-27	498	1533*	2155*	364																														
700.253	DP-S40-250N/255-36	498	1533*	2155*	364																														
700.254	DP-S40-250N/259-36	498	1533*	2155*	364																														
700.255	DP-L50-200/197-14,4	KA-50-50	J1	DN65	DN80	2"	1150	800	320	320	160	1060	90				438	1503		2125									405*	150	346			TK1	
700.256	DP-L50-200/209-18,5																498	1563		2185									357						
700.257	DP-L50-250/224-24													498	1563	2185	357																		
700.258	DP-L50-250/237-27													498	1563	2185	357																		
700.259	DP-L50-250/250-36													498	1563	2185	357																		
700.260	DP-C50-250/255-42,6													498	1563	2185	357																		
700.261	DP-C50-250/264-42,6													498	1563	2185	357																		
700.262	DP-CH50-315/291-65,3													498	1563	2185	357																		
700.263	DP-CH50-315/308-89,8													498	1563	2185	357																		

\* Tolerance of ± 50 mm  
blue components: optional available on request

Dimensions of fuel tanks on p. 61

## Dimensions - Fire fighting units Series "DP"

Fire fighting units with horizontal pumps back pull-out type  
1 Diesel main motorpump + 1 jockey pump

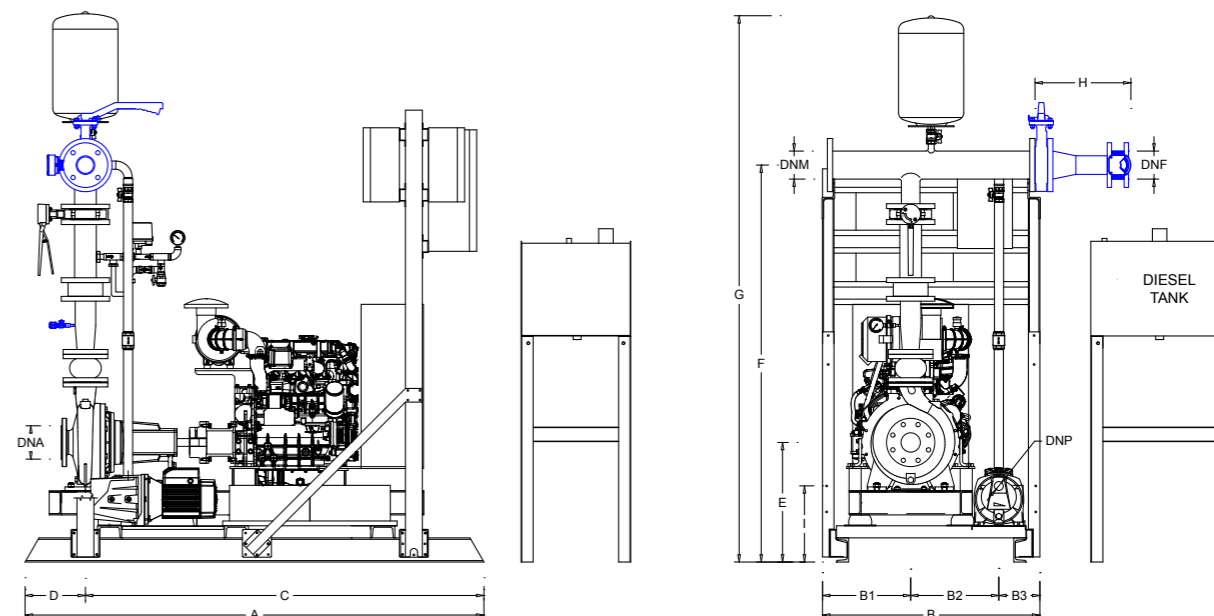

Units with capacity from m<sup>3</sup>/h 66 up to m<sup>3</sup>/h 360

Fire Fighting Unit		Flow meter kit	Jockey pump	Connections				Dimensions (mm)													Diesel Tank model
Code	Model			DNA	DNM	DNF	DNP	A	B	B1	B2	B3	C	D	E	F	G	H	I	L	
700.264	DP-L65-200/187-24	KB2-100-65	J1	DN80	DN100	1"	1330	800	320	320	160	1060	90	458	1581	2216	397	405*	150	346	TK2
700.265	DP-S65-200N/192-36													492	1615	2233	402				
700.266	DP-L65-200/198-27													492	1615	2233	402				
700.267	DP-L65-200/210-36													492	1615	2233	397				
700.268	DP-S65-200N/215-42,6													475	1600	2217	402				
700.269	DP-L65-250/241-42,6													475	1600	2217	402				
700.270	DP-L65-250/258-50													475	1600	2217	402				
700.271	DP-S65-250N/222-42,6													475	1600	2217	402				
700.272	DP-S65-250N/245-65,3													475	1600	2217	402				
700.273	DP-S65-250N/255-65,3													475	1600	2217	402				
700.274	DP-S65-250N/259-65,3	475	1600	2217	402																
700.275	DP-S65-315R/273-89,8	KB2-100-80	J2	DN80	DN100	1 1/2"	1900	900	365	365	170	1650	250	495	1644	2262	405*	150	315	TK3	
700.276	DP-S65-315R/282-89,8													495	1644	2262			397		
700.277	DP-L80-200/189-36													495	1644	2262			397		
700.278	DP-L80-200/207-42,5													495	1644	2262			397		
700.279	DP-L80-250/225-50													495	1644	2262			397		
700.280	DP-L80-250/238-65,3													495	1644	2262			397		
700.281	DP-L80-250/256-89,8													495	1644	2262			397		
700.282	DP-L80X-250/270-133,4													495	1644	2262			397		
700.283	DP-C80-200/205-65,3													495	1644	2262			397		
700.284	DP-C80-200/214-65,3													495	1644	2262			397		
700.285	DP-C80-250/235-65,3	KB2-125-80	J3	DN80	DN125	1 1/4"	2350	1250	495	585	170	1650	250	495	1717	2348	405*	150	190	TK4	
700.286	DP-C80-250/255-89,8													495	1717	2348			420		
700.287	DP-C80-250/264-133,4													495	1717	2348			420		
700.288	DP-S80-250/269-177,5													495	1717	2348			420		
700.289	DP-S80-315R/302-177,5													495	1717	2348			420		

\* Tolerance of ± 50 mm  
blue components: optional available on request

Dimensions of fuel tanks on p. 61

# Dimensions - Fire fighting units Series "DP"

Fire fighting units with horizontal pumps back pull-out type  
**1 Diesel main motorpump + 1 jockey pump**

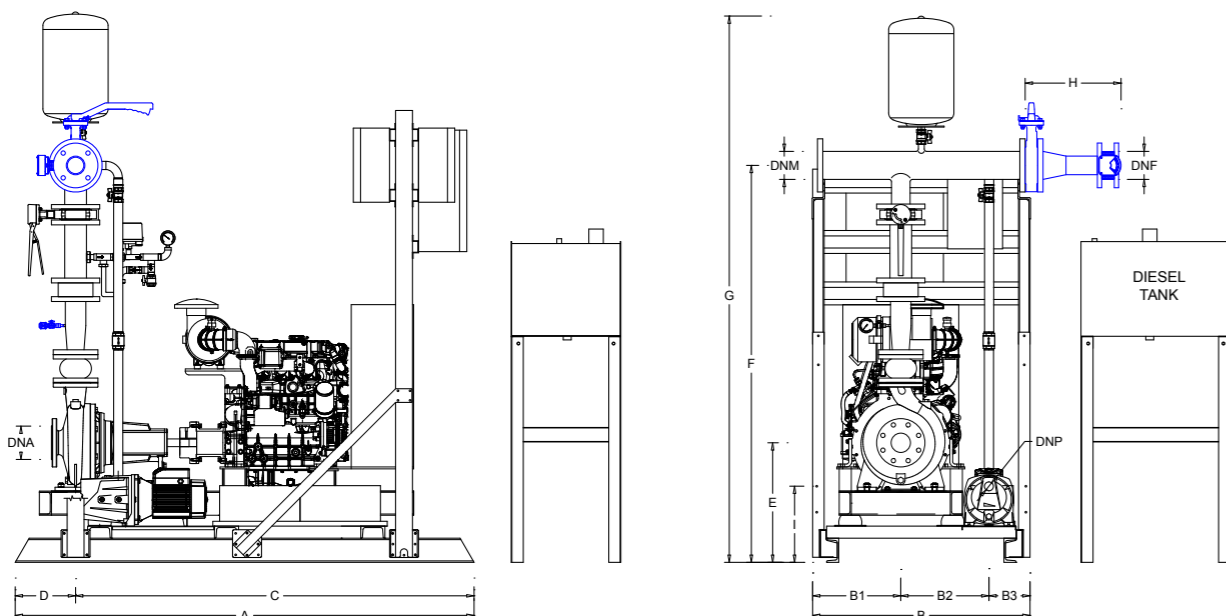

Units with capacity from m³/h 150 up to m³/h 750

Fire Fighting Unit		Flow meter kit	Jockey pump	Connections				Dimensions (mm)											Diesel Tank model					
Code	Model			DNA	DNM	DNF	DNP	A	B	B1	B2	B3	C	D	E	F	G	H		I				
700.290	DP-L100-200/192-42,6	KC-150-125	J1	DN125	DN150	DN125	1"	1900	900	365	365	1650	250	495	1776	2421	297	TK3						
700.291	DP-L100-200/203-50													520	1801	2446		315	TK4					
700.292	DP-L100-250/221-65,3		J2				1 1/4"	2350	1250	495	585	2190	160	600	1881	2526	215	TK6						
700.293	DP-L100-250/235-89,8																	TK5						
700.294	DP-L100-250/254-133,4		J3				1"	1900	900	365	365	170	1650	250	495	1776	2421	472	297	TK5				
700.295	DP-L100-250/267-133,4														520	1801	2446		315	TK5				
700.296	DP-S100-200A/219-89,8		KC-200-150				J1	DN150	DN200	DN200	1 1/4"	2350	1250	495	585	2190	160	600	1881	2526	215	TK6		
700.297	DP-S100-250CD/233-89,8																	625	1941	2586		TK7		
700.298	DP-S100-250B/250-133,4						J2				1"	1900	900	365	365	170	1650	250	495	1776	2421	536	297	TK5
700.299	DP-S100-250AB/265-133,4																		520	1801	2446		315	TK5
700.300	DP-S100-250A/269-133,4	J3		1 1/4"	2350	1250	495				585	2190	160	625	2077	2772	438	536	215	TK6				
700.301	DP-CH100-315/291-177,5		TK7																					
700.302	DP-CH100-315/308-177,5	J4	1"	1900	900	365	365	170	1650	250	545	1957	2652	536	297	TK4								
700.303	DP-L125-200/206-65,3	J1	1 1/4"	2350	1250	495	585	170	2190	160	625	2077	2772		536	215	TK5							
700.304	DP-L125-200/216-89,8	KC-200-125	J2	DN150	DN200	DN200	1 1/4"	2350	1250	495	585	2190	160	655	2107	2802	536	215	TK6					
700.305	DP-CH125-250/222-89,8													655	2107	2802		536	215	TK7				
700.306	DP-L125-270/224-133,4	KC-200-200	J3	DN150	DN200	DN200	1 1/4"	2500	170	2340	160	655	2290	2992	636	215	TK8							
700.307	DP-L125-270/237-133,4																TK8							
700.308	DP-L125-270/253-177,5	KC-200-150	J4	DN200	DN250	DN200	1 1/4"	2500	170	2340	160	655	2290	2992	636	215	TK9							
700.309	DP-CH125-250/264-177,5																TK9							
700.310	DP-L125-270/266-177,5	KC-200-200	J3	DN200	DN250	DN200	1 1/4"	2500	170	2340	160	655	2290	2992	636	215	TK10							
700.311	DP-CH125-250/278-200,7																TK10							
700.312	DP-S125-315R/302-242	KC-250-200	J2	DN200	DN250	DN200	1 1/4"	2500	170	2340	160	655	2290	2992	636	215	TK8							
700.313	DP-S150-315R/257-242																TK8							
700.314	DP-S150-315R/266-242	J3	1 1/4"	2500	1250	495	585	170	2340	160	655	2290	2992	636	215	TK9								
700.315	DP-S150-315R/280-272															TK9								
700.316	DP-S150-315R/290-302	J3	1 1/4"	2500	1250	495	585	170	2340	160	655	2290	2992	636	215	TK10								

\* Tolerance of ± 50 mm  
 blue components: optional available on request

Dimensions of fuel tanks on p. 61

## Note

The technical data contained in this catalog shall be considered binding and can be changed without notice, the figures are illustrative representations and are not binding. We reserve the right to make changes without prior notice.

# 3.5

Fire fighting units with horizontal pumps back pull-out type, made according to standard EN 12845

**2 Electric main pumps + 1 jockey pump**  
**“2EP” Series**

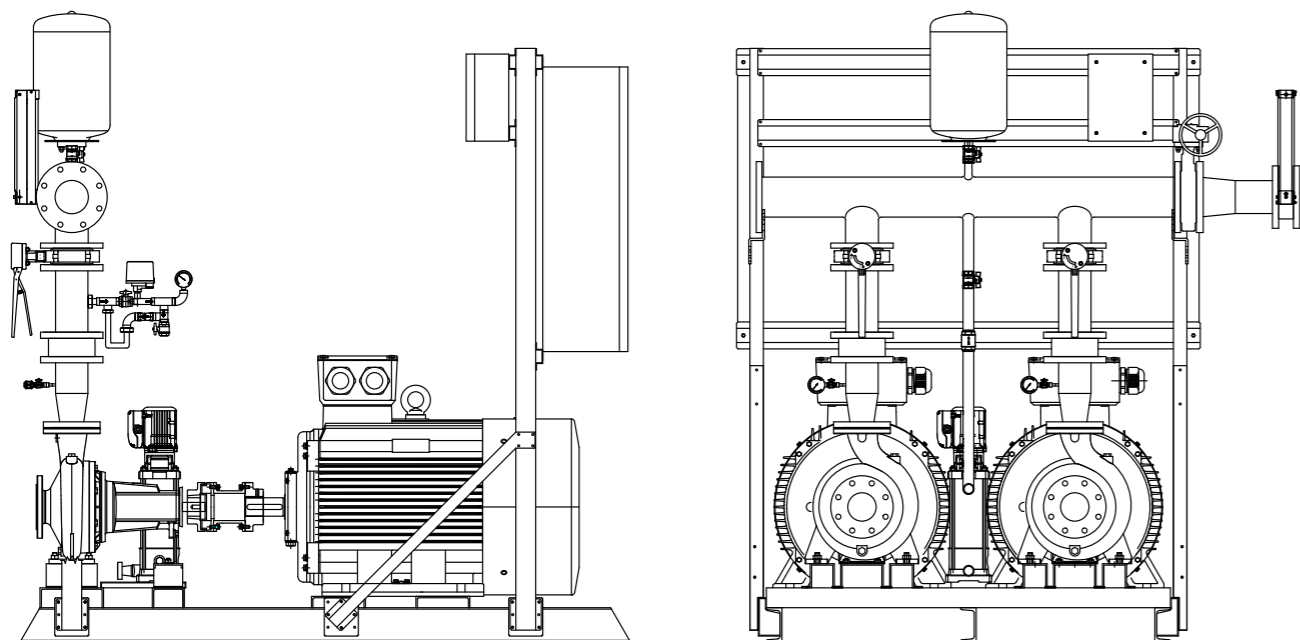

Fire fighting unit according to standard EN 12845, consists of 2 electric main pump + 1 jockey pump:

Main centrifugal pumps “back pull-out” according to EN 733 (formerly DIN 24255) axial suction and radial discharge, cast iron pump casing, mechanical seal, coupling performed by means of flexible coupling spacer with three-phase asynchronous electric motor. The fire fighting unit is complete with 2 electric main pumps and a jockey pump mounted on a painted steel base, electrically wired to the electrical control panels installed on board skid (for power ≥ kW 160, the electric panels of the main pumps are supplied

loose cabinet metal size = WxHxD mm 800x1800x430 and its wiring with the group will be at the customer). The standard supply of the Fire unit Series “2EP” does not include either the suction valves or suction eccentric enlargements of the main pumps, which must be ordered separately (suction reducing eccentric be sized according to the directions of the standard EN 12845).

Fire fighting units with horizontal pumps back pull-out type, made according to standard EN 12845

**2 Electric main pumps + 1 jockey pump**  
**“2EP” Series**

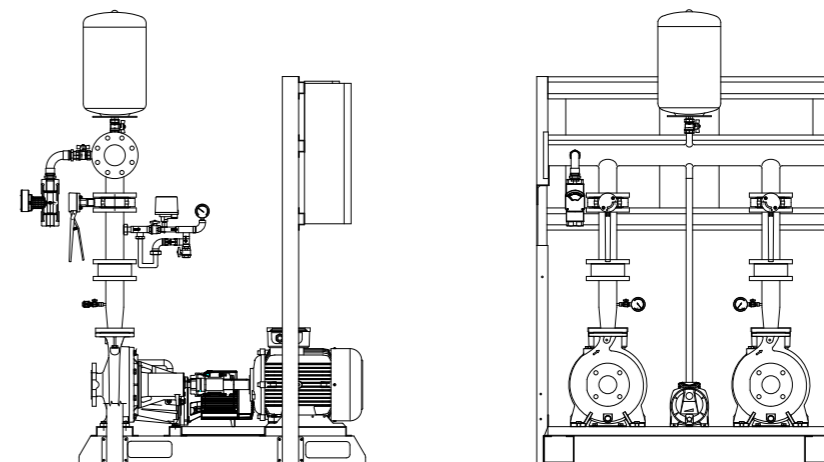

Units with capacity from m³/h 0 up to m³/h 96

Code	Model	Electric Power (kW)	Q= CAPACITY OF EACH SERVICE PUMP																		
			m³/h 0	7,2	9	14,4	18	21,6	24	27	28,8	30	36	43,2	50,4	54	60	72	84	90	96
			l/m 0	120	150	240	300	360	400	450	480	500	600	720	840	900	1000	1200	1400	1500	1600
			H= Total head ( m.c.a. )																		
700.317	2EP-L32-200/188-4	2x3+1.1	44	41	40	35	32*	27	24	20											
700.318	2EP-L32-200/204-5,5	2x4+1.1	54	51	45	45	42	37*	34	30	27	26									
700.319	2EP-S32-200N/206-7,5	2x5.5+1.1	54			51	49	46	44*	40	36	35									
700.320	2EP-S32-200N/219-10	2x7.5+1.1	63			62	61	60	57*	54	52	50	36								
700.321	2EP-L32X-250/256-15	2x11+2.2	86			74	71	66*	63	59											
700.322	2EP-C32-250/225-20	2x15+2.2	69				69	68	67	65	63	62*	53								
700.323	2EP-C32-250/235-20	2x15+2.2	77				76	75	74	73	71	70*	61								
700.324	2EP-C32-250/255-25	2x18.5+2.2	89				89	88	87	85	84	83	75*	60							
700.325	2EP-C32-250/264-25	2x18.5+2.2	96				95	94	92	91	89	88	80*	64							
700.326	2EP-S40-200/190-10	2x7.5+1.1	46				44	43	41	40	39	38*	33	26	20						
700.327	2EP-L40-200/209-10	2x7.5+1.1	57				54	52	51	50	49	48	46*	41							
700.328	2EP-S40-200/212-12,5	2x9.2+1.1	58				58	56	55	54	53	52	47*	41	35						
700.329	2EP-L40-250/233-15	2x11+2.2	72				68	65	64	63	62	61	57	52*	44						
700.330	2EP-L40-250/251-20	2x15+2.2	85				80	78	77	75	74	73	70	65*	56	53					
700.331	2EP-S40-250N/240-25	2x18.5+2.2	81						79	78	77	76	75	69	68*	65	61	51			
700.332	2EP-S40-250N/255-30	2x22+2.2	95						89	88	87	86	84	80	76*	74	69	55			
700.333	2EP-S40-250N/259-40	2x30+2.2	98						92	91	91,5	90	87	81	79*	76	71	59			
700.334	2EP-L50-200/197-15	2x11+1.1	51									48	47	45	42	41	38*	33	26		
700.335	2EP-L50-200/209-15	2x11+1.1	58									55	54	53	50	49	43*	40	33	29	
700.336	2EP-L50-250/224-20	2x15+2.2	68									64	63	60	59	56*	50	41			
700.337	2EP-L50-250/237-25	2x18.5+2.2	77									73	72	70	68	66	60*	52	47		
700.338	2EP-L50-250/250-30	2x22+2.2	86									83	81	79	78	75	70*	61	57	52	
700.339	2EP-C50-250/255-40	2x30+2.2	95									92	90,5	88	86	83*	72	50	36		
700.340	2EP-C50-250/264-50	2x37+2.2	104									101	99	96	94	91	83*	61	54	26	
700.341	2EP-CH50-315/291-75	2x55+3	118									114	113	110	108	106	98*	82	74		
700.342	2EP-CH50-315/308-100	2x75+4	132									129	127	125	123	122	116	106*	100	90	

Tolerances in table: ISO 9906 Annex A (performance at the outlet of the pump)  
Gray boxes: NPSH ≥ 5m (possible installation only with positive suction head)  
\* maximum efficiency point

## Fire fighting units with horizontal pumps back pull-out type, made according to standard EN 12845

### 2 Electric main pumps + 1 jockey pump “2EP” Series

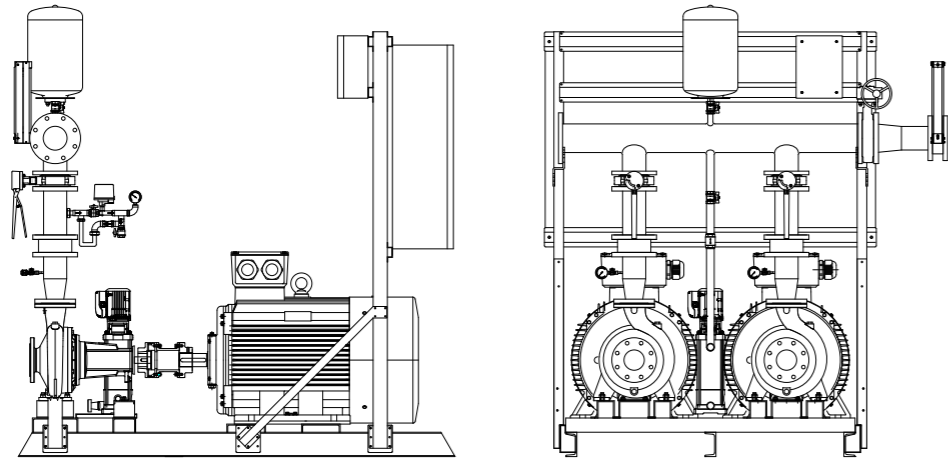

Units with capacity from m³/h 66 up to m³/h 360

Code	Model	Electric Power (kW)	Q= CAPACITY OF EACH SERVICE PUMP														
			m³/h 0	66	72	90	108	120	150	180	210	240	270	300	330	360	
			l/m 0	1100	1200	1500	1800	2000	2500	3000	3500	4000	4500	5000	5500	6000	
H= Total head ( m.c.a. )																	
700.343	2EP-L65-200/187-20	2x15+1.1	45	44	43	40*	37	34									
700.344	2EP-S65-200N/192-30	2x22+1.1	50	50	48	46*	43	40	30	15							
700.345	2EP-L65-200/198-25	2x18.5+1.1	52	51	51	48	45*	42									
700.346	2EP-L65-200/210-30	2x22+1.1	59	59	58	55	52*	50									
700.347	2EP-S65-200N/215-40	2x30+2.2	65	64	64	61	58*	55	46	34							
700.348	2EP-L65-250/241-40	2x30+2.2	76	74	73	69	64*	61									
700.349	2EP-L65-250/258-50	2x37+2.2	90	87	86	83	78*	75									
700.350	2EP-S65-250N/222-40	2x30+2.2	70	68	67	65	62*	59	51								
700.351	2EP-S65-250N/245-60	2x45+2.2	83	82	82	79	76	73*	65								
700.352	2EP-S65-250N/255-60	2x45+2.2	92	92	91	89	85	83*	74	65							
700.353	2EP-S65-250N/259-75	2x55+2.2	95	94	93	92	88	85*	76	69							
700.354	2EP-S65-315R/273-75	2x55+2.2	101	100	99	96	93*	90	84								
700.355	2EP-S65-315R/282-100	2x75+3	112	111	110	108	105*	103	96	87							
700.356	2EP-L80-200/189-30	2x22+1.1	48				45	44	38*	32							
700.357	2EP-L80-200/207-40	2x30+1.1	60				58	57	52*	46	40						
700.358	2EP-L80-250/225-50	2x37+2.2	71				67	65	58*	49							
700.359	2EP-L80-250/238-60	2x45+2.2	80				78	76	70*	62							
700.360	2EP-L80-250/256-75	2x55+2.2	92				91	90	84	76*	68						
700.361	2EP-L80X-250/270-100	2x75+3	112				108	106	101	94*	83						
700.362	2EP-C80-200/205-60	2x45+1.1	58					56	53	50*	46	42					
700.363	2EP-C80-200/214-75	2x55+1.1	64					62	60	57	53*	49					
700.364	2EP-C80-250/235-75	2x55+2.2	75					70	68	64*	57	44	30				
700.365	2EP-C80-250/255-100	2x75+2.2	89					85	84	80	75*	68	56	38			
700.366	2EP-C80-250/264-100	2x75+2.2	106					90	89	87	83*	76	66	52			
700.367	2EP-S80-250/269-150	2x110+2.2	102					102	100	98	95	92*	88	85	82	77	
700.368	2EP-S80-315R/302-150	2x110+3	117					115	113	112	108*	103	90				

Tolerances in table: ISO 9906 Annex A (performance at the outlet of the pump)  
Gray boxes: NPSH ≥ 5m (possible installation only with positive suction head)  
\* maximum efficiency point

## Fire fighting units with horizontal pumps back pull-out type, made according to standard EN 12845

### 2 Electric main pumps + 1 jockey pump “2EP” Series

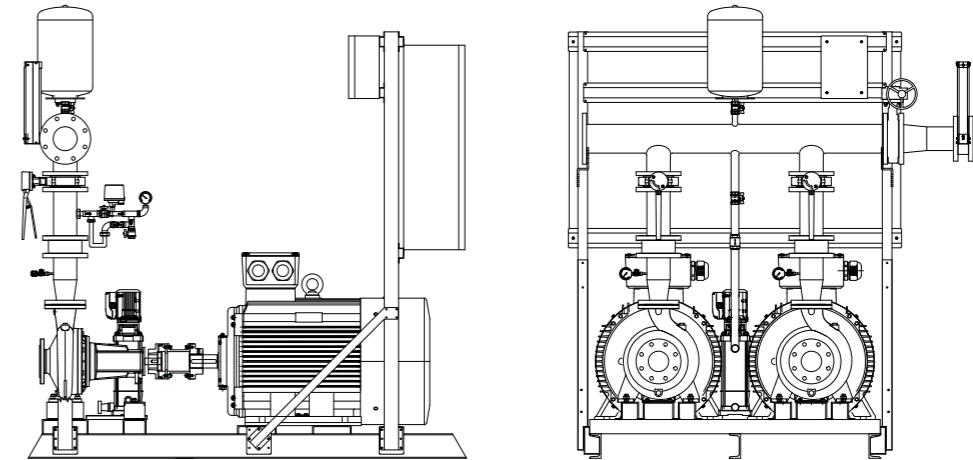

Units with capacity from m³/h 150 up to m³/h 750

Code	Model	Electric Power (kW)	Q= CAPACITY OF EACH SERVICE PUMP																
			m³/h 0	150	180	210	240	270	300	330	360	390	420	480	540	600	650	700	750
			l/m 0	2500	3000	3500	4000	4500	5000	5500	6000	6500	7000	8000	9000	10000	10833	11667	12500
H= Total head ( m.c.a. )																			
700.369	2EP-L100-200/192-40	2x30+1.1	49	45	42	38*	34	30	24										
700.370	2EP-L100-200/203-50	2x37+1.1	56	52	50	46	42*	38	33	26									
700.371	2EP-L100-250/221-60	2x45+2.2	69	65	59	56*	50	45	35										
700.372	2EP-L100-250/235-75	2x55+2.2	79	75	72	69	64*	56	50										
700.373	2EP-L100-250/254-100	2x75+2.2	92	89	86	84	80	75*	67										
700.374	2EP-L100-250/267-125	2x90+2.2	103	100	98	95	90	85*	80										
700.375	2EP-S100-200/219-75	2x55+1.1	62,5	60	59	57,5	55	52,5	49*	43	37,5								
700.376	2EP-S100-250/233-100	2x75+2.2	68	67	64	61	57	55*	49	43	30								
700.377	2EP-S100-250/250-100	2x75+2.2	80	79	77	75	72	69	64*	59	53								
700.378	2EP-S100-250/265-125	2x90+2.2	95	92	90	88	86	84	80*	75	70								
700.379	2EP-S100-250/269-150	2x110+2.2	97	95	94	92	90	86	83*	78	74								
700.380	2EP-CH100-315/291-150	2x110+3	117	114	111	108	102	96*	87	74									
700.381	2EP-CH100-315/308-180	2x132+4	131	130	128	124	120	115	106*	96	84								
700.382	2EP-L125-200/206-60	2x45+1.1	47				38	36	34	32	30*	28	22						
700.383	2EP-L125-200/216-75	2x55+1.1	57				49	47	45	42	40	38*	31	22					
700.384	2EP-CH125-250/222-100	2x75+1.1	59				55	53	50*	47	43								
700.385	2EP-L125-270/224-100	2x75+2.2	65				59	56	55	53	50*	48	47	35					
700.386	2EP-L125-270/237-125	2x90+2.2	75				70	68	65	65	61	60*	54	45	36				
700.387	2EP-L125-270/253-150	2x110+2.2	88				82	80	78	76	74	71	66*	57	46				
700.388	2EP-CH125-250/264-180	2x132+2.2	91				90	88	86	84	81	77*	72	62					
700.389	2EP-L125-270/266-180	2x132+2.2	97				91	90	87	86	84	81	76*	70	60				
700.390	2EP-CH125-250/278-218	2x160+2.2	102				101	100	99	97	95	93	87*	80	71				
700.391	2EP-S125-315R/302-272	2x200+3	124					118	117	115	112	109*	105	102	90				
700.392	2EP-S150-315R/257-218	2x160+2.2	70					68	67	66	64	62	58	52*	47	42	35		
700.393	2EP-S150-315R/266-218	2x160+2.2	85					82	81	80	78	76	72	68*	62	56	50		
700.394	2EP-S150-315R/280-272	2x200+2.2	97					94	93	92	90	88	85	80*	75	70	62	53	
700.395	2EP-S150-315R/290-340	2x250+2.2	107					106	105	103	102	101	97	95*	90	85	80	75	

Tolerances in table: ISO 9906 Annex A (performance at the outlet of the pump)  
Gray boxes: NPSH ≥ 5m (possible installation only with positive suction head)  
\* maximum efficiency point

## Dimensions - Fire fighting units Series "2EP"

Fire fighting units with horizontal pumps back pull-out type  
2 Electric main pumps + 1 jockey pump

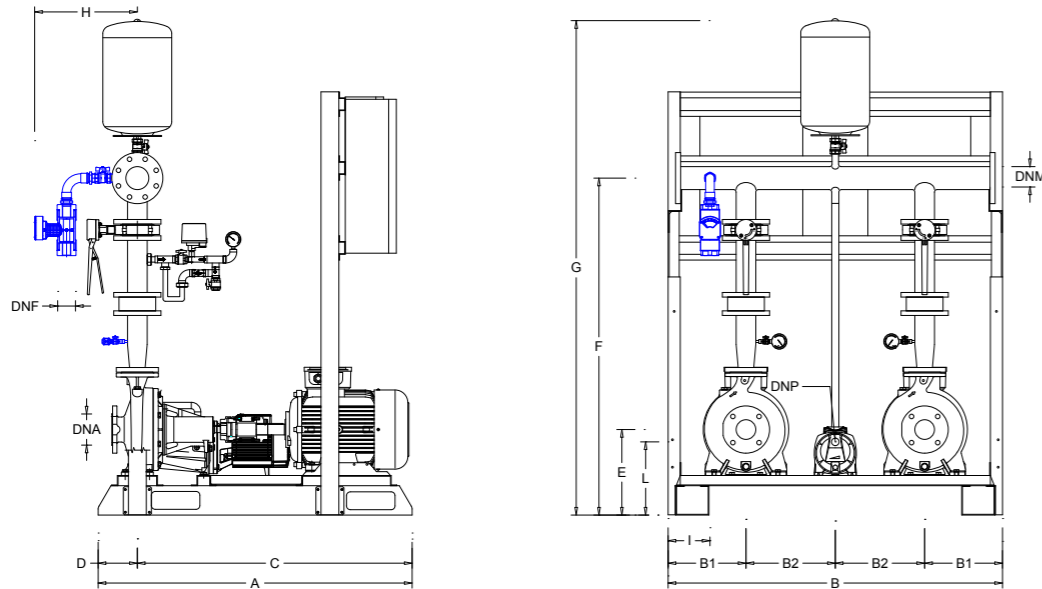

Units with capacity from m<sup>3</sup>/h 0 up to m<sup>3</sup>/h 96

Fire Fighting Unit		Flow meter kit	Jockey pump	Connections				Dimensions (mm)										
Code	Model			DNA	DNM	DNF	DNP	A	B	B1	B2	C	D	E	F	G	H	I
700.317	2EP-L32-200/188-4	KA-32-32	J1	DN50	DN65	1 1/4"	1230	1310	305	350	1077	153	315	1210*	1824*	405*	150	302
700.318	2EP-L32-200/204-5,5																	
700.319	2EP-S32-200N/206-7,5																	
700.320	2EP-S32-200N/219-10																	
700.321	2EP-L32X-250/256-15																	
700.322	2EP-C32-250/225-20	J2	1 1/4"	1230	1310	305	350	1077	153	1077	153	335	1275*	1890*	405*	150	320	
700.323	2EP-C32-250/235-20																	
700.324	2EP-C32-250/255-25	KA-40-40	J3	DN50	DN65	1 1/2"	1230	1310	305	350	1077	153	315	1210*	1824*	405*	150	302
700.325	2EP-C32-250/264-25																	
700.326	2EP-S40-200/190-10																	
700.327	2EP-L40-200/209-10	KA-40-40	J1	DN65	DN65	1 1/2"	1230	1310	305	350	1077	153	315	1210*	1824*	405*	150	320
700.328	2EP-S40-200/212-12,5																	
700.329	2EP-L40-250/233-15																	
700.330	2EP-L40-250/251-20	KA-50-50	J2	DN65	DN65	1 1/4"	1230	1310	305	350	1077	153	335	1275*	1890*	405*	150	320
700.331	2EP-S40-250N/240-25																	
700.332	2EP-S40-250N/255-30	KA-50-50	J3	DN65	DN65	2"	1450	1360	330	350	1285	165	355	1295*	1910*	405*	150	320
700.333	2EP-S40-250N/259-40																	
700.334	2EP-L50-200/197-15	KA-50-50	J1	DN65	DN80	1"	1230	1310	305	350	1077	153	315	1275	1890	405*	150	302
700.335	2EP-L50-200/209-15																	
700.336	2EP-L50-250/224-20	KA-50-50	J2	DN65	DN80	2"	1230	1310	305	350	1077	153	335	1320	1937	405*	150	320
700.337	2EP-L50-250/237-25																	
700.338	2EP-L50-250/250-30	KB1-65-65	J2	DN65	DN80	DN65	1450	1360	330	350	1285	165	355	1340	1957	405*	150	325
700.339	2EP-C50-250/255-40																	
700.340	2EP-C50-250/264-50	KA-50-50	J3	DN65	DN80	2"	1450	1360	330	350	1285	165	355	1340	1957	405*	150	325
700.341	2EP-CH50-315/291-75																	
700.342	2EP-CH50-315/308-100																	

\* Tolerance of ± 50 mm  
blue components: optional available on request

## Dimensions - Fire fighting units Series "2EP"

Fire fighting units with horizontal pumps back pull-out type  
2 Electric main pumps + 1 jockey pump

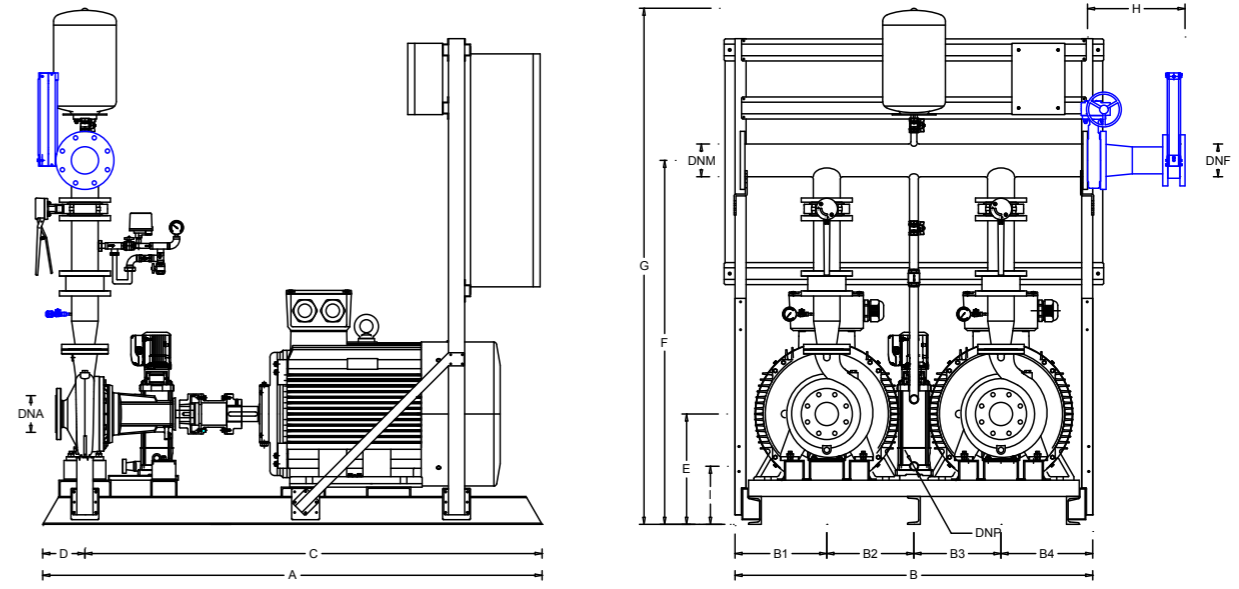

Units with capacity from m<sup>3</sup>/h 66 up to m<sup>3</sup>/h 360

Fire Fighting Unit		Flow meter kit	Jockey pump	Connections				Dimensions (mm)											
Code	Model			DNA	DNM	DNF	DNP	A	B	B1	B2	B3	B4	C	D	E	F	G	H
700.343	2EP-L65-200/187-20	KB2-100-65	J1	DN80	DN100	1"	1230	1310	305	305	1077	153	335	1344	1973	402	302		
700.344	2EP-S65-200N/192-30																		
700.345	2EP-L65-200/198-25	KB2-100-65	J1	DN80	DN100	1"	1230	1310	305	350	350	1077	153	335	1344	1973	402	302	
700.346	2EP-L65-200/210-30																		
700.347	2EP-S65-200N/215-40	KB2-100-80	J2	DN80	DN100	1 1/4"	1450	1360	330	330	1285	165	355	1357	1993	402	320		
700.348	2EP-L65-250/241-40																		
700.349	2EP-L65-250/258-50	KB2-100-65	J3	DN80	DN100	1 1/4"	1450	1360	330	330	1285	165	355	1388	2018	397	195		
700.350	2EP-S65-250N/222-40																		
700.351	2EP-S65-250N/245-60	KB2-100-80	J2	DN80	DN100	1 1/4"	1700	1516	383	375	375	383	1515	185	385	1419	2048	402	320
700.352	2EP-S65-250N/255-60																		
700.353	2EP-S65-250N/259-75	KB2-100-80	J3	DN80	DN100	1 1/4"	1700	1516	383	375	375	383	1515	185	410	1474	2103	402	270
700.354	2EP-S65-315R/273-75																		
700.355	2EP-S65-315R/282-100	KB2-125-80	J4	DN80	DN100	1"	1800	1516	383	375	375	383	1515	185	440	1404	2133	402	275
700.356	2EP-L80-200/189-30																		
700.357	2EP-L80-200/207-40	KC-125-100	J1	DN100	DN125	1"	1450	1360	330	350	350	330	1285	165	355	1417	2071	420	302
700.358	2EP-L80-250/225-50																		
700.359	2EP-L80-250/238-60	KB2-125-80	J2	DN80	DN100	1 1/4"	1700	1516	383	375	375	383	1515	185	385	1477	2132	426	350
700.360	2EP-L80-250/256-75																		
700.361	2EP-L80X-250/270-100	KC-125-100	J3	DN100	DN125	1 1/4"	1800	1516	383	375	375	383	1515	185	410	1502	2157	420	220
700.362	2EP-L80X-250/270-100																		
700.363	2EP-C80-200/205-60	KC-125-100	J1	DN100	DN125	1"	1700	1516	383	375	375	383	1515	185	385	1447	2101	426	350
700.364	2EP-C80-200/214-75																		
700.365	2EP-C80-250/235-75	KC-125-100	J2	DN100	DN125	1 1/4"	1800	1516	383	375	375	383	1515	185	410	1472	2127	420	307
700.366	2EP-C80-250/255-100																		
700.367	2EP-C80-250/264-100	KC-125-100	J3	DN100	DN125	1 1/4"	1800	1516	383	375	375	383	1515	185	440	1532	2187	420	250
700.368	2EP-S80-250/269-150*																		
700.368	2EP-S80-315R/302-150*	KC-125-100	J4	DN100	DN125	1 1/4"	2150	2212	523	411	755	523	1965	185	475	1567	2222	420	315
700.368	2EP-S80-315R/302-150*																		

\* Supply on 2 different skids ( E + EP connected between with elastic compensator )  
blue components: optional available on request

# Dimensions - Fire fighting units Series "2EP"

Fire fighting units with horizontal pumps back pull-out type  
2 Electric main pumps + 1 jockey pump

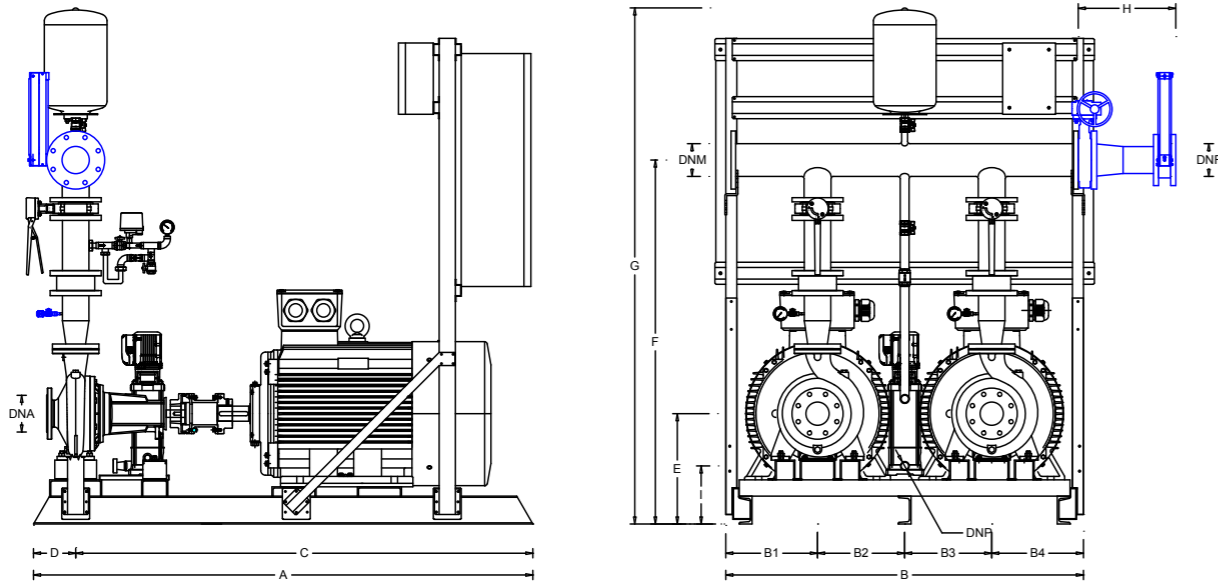

Units with capacity from m³/h 150 up to m³/h 750

Code	Fire Fighting Unit Model	Flow meter kit	Jo-ckey pump	Connections				Dimensions (mm)																													
				DNA	DNM	DNF	DNP	A	B	B1	B2	B3	B4	C	D	E	F	G	H	I																	
700.369	2EP-L100-200/192-40	KC-150-125	J1	DN125	DN150	DN125	1"	1450	1360	330	375	375	383	330	1285	165	355	1501	2145	472	302																
700.370	2EP-L100-200/203-50		J2				1 1/4"	1700	1516	383												375	375	383	1518	182	410	1556	2201	385	1531	2176	410	1556	2201	325	
700.371	2EP-L100-250/221-60						1800	1618																													440
700.372	2EP-L100-250/235-75		J3				1 1/4"		1800	1516												383	375	375	383	1518	182	410	1556	2201	385	1531	2176	410	1556	2201	
700.373	2EP-L100-250/254-100						1700	1618	440																												1586
700.374	2EP-L100-250/267-125		J3				1 1/4"			1800												1516	383	375	375	383	1518	182	410	1556	2201	385	1531	2176	410	1556	
700.375	2EP-S100-200/219-75						J1	1"	1700	1516																											383
700.376	2EP-S100-250/233-100		J2				1 1/4"	1800	1516													383	375	375	383	1518	182	410	1556	2201	385	1531	2176	410	1556	2201	
700.377	2EP-S100-250/250-100		J3				1 1/4"	1800		1516																											383
700.378	2EP-S100-250/265-125						J4	1"	1700													1516	383	375	375	383	1518	182	410	1556	2201	385	1531	2176	410	1556	
700.379	2EP-S100-250/269-150*	J5	1 1/4"	2150	1516	383	375	375	383	1518	182	410	1556	2201	385	1531	2176	410	1556	2201	377																
700.380	2EP-CH100-315/291-150*	J4	1"	1700																		1516	383	375	375	383	1518	182	410	1556	2201	385	1531	2176	410	1556	2201
700.381	2EP-CH100-315/308-180*	J5	1 1/4"	2150	1516	383	375	375	383	1518	182	410	1556	2201	385	1531	2176	410	1556	2201	265																
700.382	2EP-L125-200/206-60	KC-200-150	J1	DN150																		DN200	DN150	1"	1700	1516	383	375	375	383	1518	182	410	1657	2352	536	327
700.383	2EP-L125-200/216-75		J1		1 1/4"	1700	1516	383	375	375	383	1518	182	410	1657	2352	536	327																			
700.384	2EP-CH125-250/222-100		KC-200-125		DN125	1800													1516	383	375			375	383												
700.385	2EP-L125-270/224-100		KC-200-150		J2	1 1/4"	1800	1516	383	375	375	383	1518	182	410	1657	2352	536																			
700.386	2EP-L125-270/237-125		KC-200-200		J2	1 1/4"	1800												1516	383	375			375	383												
700.387	2EP-L125-270/253-150*		KC-200-200		J2	1 1/4"	1800	1516	383	375	375	383	1518	182	410	1657	2352	536																			
700.388	2EP-CH125-250/264-180*		KC-200-150		J3	1 1/4"	2150												1516	383	375			375	383												
700.389	2EP-L125-270/266-180*		KC-200-200		J3	1 1/4"	2263	1516	383	375	375	383	1518	182	410	1657	2352	536																			
700.390	2EP-CH125-250/278-218*		KC-200-200		J3	1 1/4"	2200												1516	383	375			375	383												
700.391	2EP-S125-315R/302-272*		KC-200-150		J4	1 1/4"	2200	1516	383	375	375	383	1518	182	410	1657	2352	536																			
700.392	2EP-S150-315R/257-218*	KC-200-150	J2	1 1/4"	2200	1516	383												375	375	383	1518	182	410	1657	2352	536	327									
700.393	2EP-S150-315R/266-218*	KC-250-200	J3	1 1/4"	2200			1516	383	375	375	383	1518	182	410	1657	2352	536											327								
700.394	2EP-S150-315R/280-272*	KC-250-200	J3	1 1/4"	2200	1516	383												375	375	383	1518	182	410	1657	2352	536	327									
700.395	2EP-S150-315R/290-340*	KC-250-200	J3	1 1/4"	2200			1516	383	375	375	383	1518	182	410	1657	2352	536											327								

## Note

The technical data contained in this catalog shall be considered binding and can be changed without notice, the figures are illustrative representations and are not binding. We reserve the right to make changes without prior notice.

# 3.6

Fire fighting units with horizontal pumps back pull-out type, made according to standard EN 12845

**1 Electric main pump + 1 Diesel main motorpump + 1 jockey pump**  
**“EDP” Series**

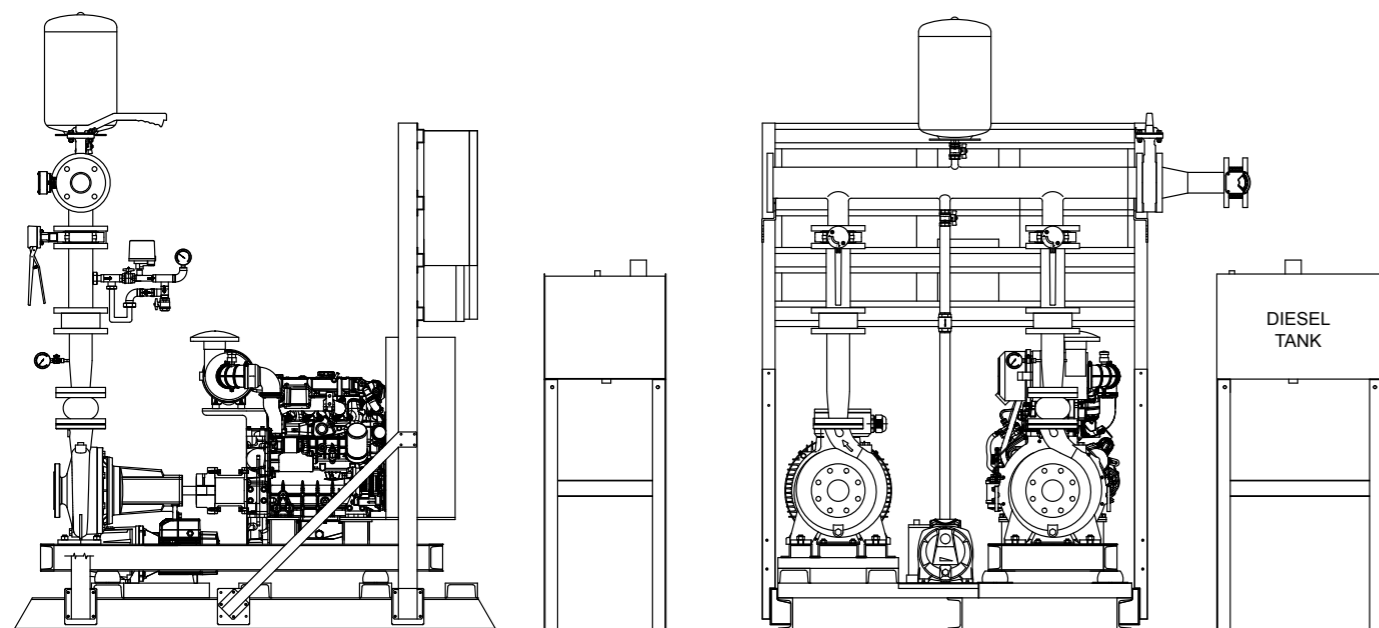

Fire fighting unit according to standard EN 12845, consists of 1 electric main pump + 1 diesel main motorpump + 1 jockey pump:

Main centrifugal pumps “back pull-out” according to EN 733 (ex DIN 24255) axial suction and radial discharge, cast iron pump casing, mechanical seal, coupling performed by means of flexible coupling spacer with three-phase asynchronous electric motor and with diesel engine fitted in compliance with EN 12845. The fire fighting unit is complete with 1 electric main pumps, 1 diesel main pump and a jockey pump mounted on a painted steel base, electrically wired to the electrical control panels installed on board skid (for power ≥ kW 160, the electric panel of the electric main pump is supplied loose cabinet metal size = WxHxD mm 800x1800x430 and its wiring

with the group will be at the customer). The standard supply of the Fire unit Series “2EP” does not include either the suction valves or suction eccentric enlargements or elastic vibration compensators of the main pumps, which must be ordered separately (suction reducing eccentric be sized according to the directions of the standard EN 12845). Diesel tank included, provided on a separate pedestal.

Fire fighting units with horizontal pumps back pull-out type, made according to standard EN 12845

**1 Electric main pump + 1 Diesel main motorpump + 1 jockey pump**  
**“EDP” Series**

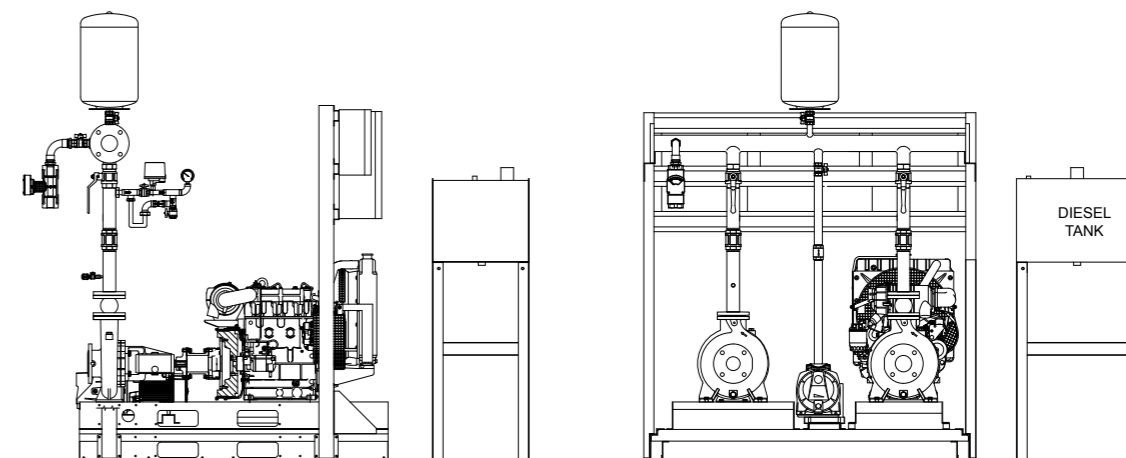

Units with capacity from m³/h 0 up to m³/h 96

Code	Model	Electric Power (kW)	Q= CAPACITY OF EACH SERVICE PUMP																			
			m³/h 0	7,2	9	14,4	18	21,6	24	27	28,8	30	36	43,2	50,4	54	60	72	84	90	96	
			l/m 0	120	150	240	300	360	400	450	480	500	600	720	840	900	1000	1200	1400	1500	1600	
			H= Total head ( m.c.a. )																			
700.396	EDP-L32-200/188-5.8	3+1.1	44	41	40	35	32*	27	24	20												
700.397	EDP-L32-200/204-5.8	4+1.1	54	51	45	45	42	37*	34	30	27	26										
700.398	EDP-S32-200N/206-8.4	5.5+1.1	54			51	49	46	44*	40	36	35										
700.399	EDP-S32-200N/219-14.4	7.5+1.1	63			62	61	60	57*	54	52	50	36									
700.400	EDP-L32X-250/256-14.4	11+2.2	86			74	71	66*	63	59												
700.401	EDP-C32-250/225-18.5	15+2.2	69				69	68	67	65	63	62*	53									
700.402	EDP-C32-250/235-24	15+2.2	77				76	75	74	73	71	70*	61									
700.403	EDP-C32-250/255-24	18.5+2.2	89				89	88	87	85	84	83	75*	60								
700.404	EDP-C32-250/264-27	18.5+2.2	96				95	94	92	91	89	88	80*	64								
700.405	EDP-S40-200/190-8.4	7.5+1.1	46				44	43	41	40	39	38*	33	26	20							
700.406	EDP-L40-200/209-14.4	7.5+1.1	57				54	52	51	50	49	48	46*	41								
700.407	EDP-S40-200/212-14.4	9.2+1.1	58				58	56	55	54	53	52	47*	41	35							
700.408	EDP-L40-250/233-18.5	11+2.2	72				68	65	64	63	62	61	57	52*	44							
700.409	EDP-L40-250/251-24	15+2.2	85				80	78	77	75	74	73	70	65*	56	53						
700.410	EDP-S40-250N/240-27	18.5+2.2	81						79	78	77	76	75	69	68*	65	61	51				
700.411	EDP-S40-250N/255-36	22+2.2	95						89	88	87	86	84	80	76*	74	69	55				
700.412	EDP-S40-250N/259-36	30+2.2	98						92	91	91,5	90	87	81	79*	76	71	59				
700.413	EDP-L50-200/197-14.4	11+1.1	51									48	47	45	42	41	38*	33	26			
700.414	EDP-L50-200/209-18.5	11+1.1	58									55	54	53	50	49	43*	40	33	29		
700.415	EDP-L50-250/224-24	15+2.2	68									64	63	60	59	56*	50	41				
700.416	EDP-L50-250/237-27	18.5+2.2	77									73	72	70	68	66*	60*	52	47			
700.417	EDP-L50-250/250-36	22+2.2	86									83	81	79	78	75	70*	61	57	52		
700.418	EDP-C50-250/255-42.6	30+2.2	95										92	90,5	88	86	83*	72	50	36		
700.419	EDP-C50-250/264-42.6	37+2.2	104											101	99	96	94	91	83*	61	54	26
700.420	EDP-CH50-315/291-65.3	55+3	118											114	113	110	108	106	98*	82	74	
700.421	EDP-CH50-315/308-89.8	75+4	132											129	127	125	123	122	116	106*	100	90

Tolerances in table: ISO 9906 Annex A (performance at the outlet of the pump)  
 Gray boxes: NPSH ≥ 5m (possible installation only with positive suction head)  
 \* maximum efficiency point

Fire fighting units with horizontal pumps back pull-out type, made according to standard EN 12845

**1 Electric main pump + 1 Diesel main motorpump + 1 jockey pump**  
**“EDP” Series**

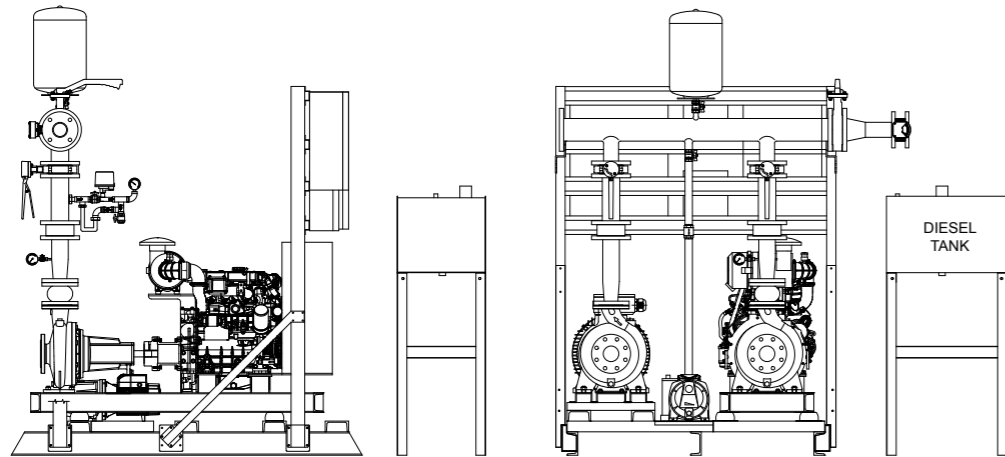

Units with capacity from m³/h 66 up to m³/h 360

Code	Model	Electric Power (kW)	Q= CAPACITY OF EACH SERVICE PUMP															
			m³/h 0	66	72	90	108	120	150	180	210	240	270	300	330	360		
			l/m 0	1100	1200	1500	1800	2000	2500	3000	3500	4000	4500	5000	5500	6000		
H= Total head ( m.c.a. )																		
700.422	EDP-L65-200/187-24	15+1.1	45	44	43	40*	37	34										
700.423	EDP-S65-200N/192-36	22+1.1	50	50	48	46*	43	40	30	15								
700.424	EDP-L65-200/198-27	18.5+1.1	52	51	51	48	45*	42										
700.425	EDP-L65-200/210-36	22+1.1	59	59	58	55	52*	50										
700.426	EDP-S65-200N/215-42.6	30+2.2	65	64	64	61	58*	55	46	34								
700.427	EDP-L65-250/241-42.6	30+2.2	76	74	73	69	64*	61										
700.428	EDP-L65-250/258-50	37+2.2	90	87	86	83	78*	75										
700.429	EDP-S65-250N/222-42.6	30+2.2	70	68	67	65	62*	59	51									
700.430	EDP-S65-250N/245-65.3	45+2.2	83	82	82	79	76	73*	65									
700.431	EDP-S65-250N/255-65.3	45+2.2	92	92	91	89	85	83*	74	65								
700.432	EDP-S65-250N/259-65.3	55+2.2	95	94	93	92	88	85*	76	69								
700.433	EDP-S65-315R/273-89.8	55+2.2	101	100	99	96	93*	90	84									
700.434	EDP-S65-315R/282-89.8	75+3	112	111	110	108	105*	103	96	87								
700.435	EDP-L80-200/189-36	22+1.1	48				45	44	38*	32								
700.436	EDP-L80-200/207-42.5	30+1.1	60				58	57	52*	46	40							
700.437	EDP-L80-250/225-50	37+2.2	71				67	65	58*	49								
700.438	EDP-L80-250/238-65.3	45+2.2	80				78	76	70*	62								
700.439	EDP-L80-250/256-89.8	55+2.2	92				91	90	84	76*	68							
700.440	EDP-L80X-250/270-133.4	75+3	112				108	106	101	94*	83							
700.441	EDP-C80-200/205-65.3	45+1.1	58				56	53	50*	46	42							
700.442	EDP-C80-200/214-65.3	55+1.1	64				62	60	57	53*	49							
700.443	EDP-C80-250/235-65.3	55+2.2	75				70	68	64*	57	44	30						
700.444	EDP-C80-250/255-89.8	75+2.2	89				85	84	80	75*	68	56	38					
700.445	EDP-C80-250/264-133.4	75+2.2	106				90	89	87	83*	76	66	52					
700.446	EDP-S80-250/269-177.5	110+2.2	102				102	100	98	95	92*	88	85	82	77			
700.447	EDP-S80-315R/302-177.5	110+3	117				115	113	112	108*	103	90						

Tolerances in table: ISO 9906 Annex A (performance at the outlet of the pump)  
 Gray boxes: NPSH ≥ 5m (possible installation only with positive suction head)  
 \* maximum efficiency point

Fire fighting units with horizontal pumps back pull-out type, made according to standard EN 12845

**1 Electric main pump + 1 Diesel main motorpump + 1 jockey pump**  
**“EDP” Series**

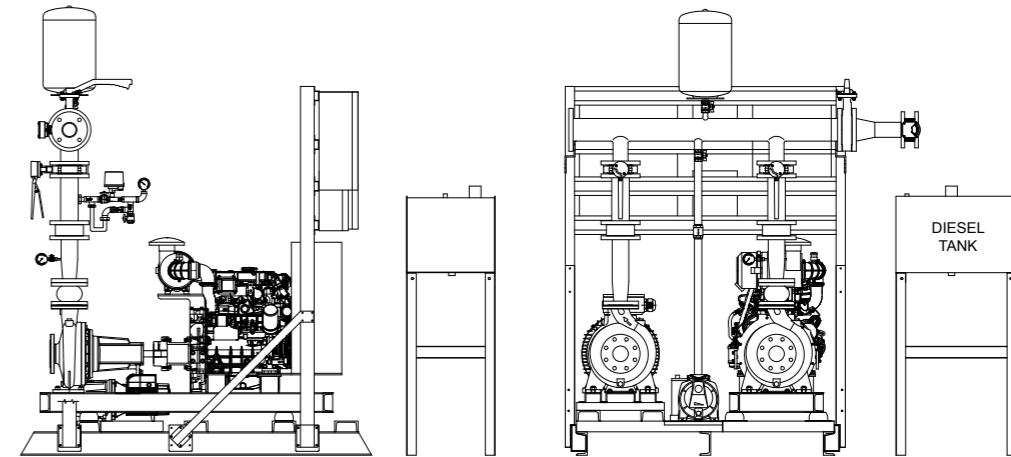

Units with capacity from m³/h 150 up to m³/h 750

Code	Model	Electric Power (kW)	Q= CAPACITY OF EACH SERVICE PUMP																
			m³/h 0	150	180	210	240	270	300	330	360	390	420	480	540	600	650	700	750
			l/m 0	2500	3000	3500	4000	4500	5000	5500	6000	6500	7000	8000	9000	10000	10833	11667	12500
H= Total head ( m.c.a. )																			
700.448	EDP-L100-200/192-42.6	30+1.1	49	45	42	38*	34	30	24										
700.449	EDP-L100-200/203-50	37+1.1	56	52	50	46	42*	38	33	26									
700.450	EDP-L100-250/221-65.3	45+2.2	69	65	59	56*	50	45	35										
700.451	EDP-L100-250/235-89.8	55+2.2	79	75	72	69	64*	56	50										
700.452	EDP-L100-250/254-133.4	75+2.2	92	89	86	84	80	75*	67										
700.453	EDP-L100-250/267-133.4	90+2.2	103	100	98	95	90	85*	80										
700.454	EDP-S100-200/219-89.8	55+1.1	62,5	60	59	57,5	55	52,5	49*	43	37,5								
700.455	EDP-S100-250/233-89.8	75+2.2	68	67	64	61	57	55*	49	43	30								
700.456	EDP-S100-250/250-133.4	75+2.2	80	79	77	75	72	69	64*	59	53								
700.457	EDP-S100-250/265-133.4	90+2.2	95	92	90	88	86	84	80*	75	70								
700.458	EDP-S100-250/269-133.4	110+2.2	97	95	94	92	90	86	83*	78	74								
700.459	EDP-CH100-315/291-177.5	110+3	117	114	111	108	102	96*	87	74									
700.460	EDP-CH100-315/308-177.5	132+4	131	130	128	124	120	115	106*	96	84								
700.461	EDP-L125-200/206-65.3	45+1.1	47				38	36	34	32	30*	28	22						
700.462	EDP-L125-200/216-89.8	55+1.1	57				49	47	45	42	40	38*	31	22					
700.463	EDP-CH125-250/222-89.8	75+1.1	59				55	53	50*	47	43								
700.464	EDP-L125-270/224-133.4	75+2.2	65				59	56	55	53	50*	48	47	35					
700.465	EDP-L125-270/237-133.4	90+2.2	75				70	68	65	65	61	60*	54	45	36				
700.466	EDP-L125-270/253-177.5	110+2.2	88				82	80	78	76	74	71	66*	57	46				
700.467	EDP-CH125-250/264-177.5	132+2.2	91				90	88	86	84	81	77*	72	62					
700.468	EDP-L125-270/266-177.5	132+2.2	97				91	90	87	86	84	81	76*	70	60				
700.469	EDP-CH125-250/278-200.7	160+2.2	102				101	100	99	97	95	93	87*	80	71				
700.470	EDP-S125-315R/302-242	200+3	124				118	117	115	112	109*	105	102	90					
700.471	EDP-S150-315R/257-242	160+2.2	70						68	67	66	64	62	58	52*	47	42	35	
700.472	EDP-S150-315R/266-242	160+2.2	85						82	81	80	78	76	72	68*	62	56	50	
700.473	EDP-S150-315R/280-272	200+2.2	97						94	93	92	90	88	85	80*	75	70	62	53
700.474	EDP-S150-315R/290-302	250+2.2	107						106	105	103	102	101	97	95*	90	85	80	75

Tolerances in table: ISO 9906 Annex A (performance at the outlet of the pump)  
 Gray boxes: NPSH ≥ 5m (possible installation only with positive suction head)  
 \* maximum efficiency point

## Dimensions - Fire fighting units Series "EDP"

Fire fighting units with horizontal pumps back pull-out type  
1 Electric main pump + 1 Diesel main motorpump + 1 jockey pump

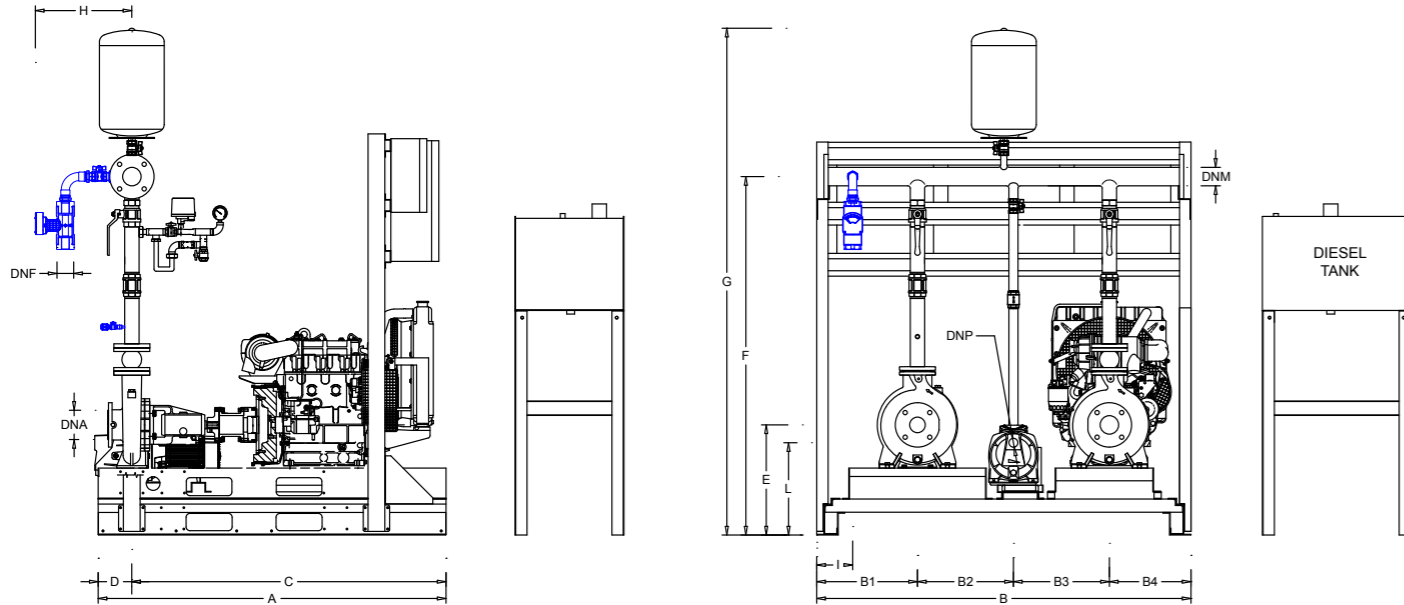

Units with capacity from m³/h 0 up to m³/h 96

Fire Fighting Unit		Flow meter kit	Jockey pump	Connections				Dimensions (mm)											Diesel Tank model																					
Code	Model			DNA	DNM	DNF	DNP	A	B	B1	B2	B3	B4	C	D	E	F	G		H	I	L																		
700.396	EDP-L32-200/188-5,8	KA-32-32	J1	DN50	DN65	1 1/4"	1300	1560	420	413	357	370	1160	140	459	1495*	2115*	405*	150	260	367	TK1																		
700.397	EDP-L32-200/204-5,8																																							
700.398	EDP-S32-200N/206-8,4																																							
700.399	EDP-S32-200N/219-14,4		J3																				1 1/2"																	
700.400	EDP-L32X-250/256-14,4																																							
700.401	EDP-C32-250/225-18,5																																							
700.402	EDP-C32-250/235-24		J2																				1 1/4"																	
700.403	EDP-C32-250/255-24																																							
700.404	EDP-C32-250/264-27		KA-40-40																				J3	1 1/2"	1450	1310	260	TK3												
700.405	EDP-S40-200/190-8,4																																							
700.406	EDP-L40-200/209-14,4																																							
700.407	EDP-S40-200/212-14,4		KA-40-40																				J1	1 1/2"	1300	1160	440	1430*	2047*	367	TK1									
700.408	EDP-L40-250/233-18,5																																							
700.409	EDP-L40-250/251-24																																							
700.410	EDP-S40-250N/240-27	KA-50-50	J2	1 1/4"	1450	1310	499	1535*	2155*	385	TK2																													
700.411	EDP-S40-250N/255-36																																							
700.412	EDP-S40-250N/259-36																																							
700.413	EDP-L50-200/197-14,4	KA-50-50	J1	DN65	DN80	DN65	1300	1560	420	413	357	370	1160	140	440	1505	2130	405*	150	215	367	TK1																		
700.414	EDP-L50-200/209-18,5																																							
700.415	EDP-L50-200/224-24																																							
700.416	EDP-L50-250/237-27		J2																				2"	1450	1310	460	1495*	2112*	405*	150	385	TK2								
700.417	EDP-L50-250/250-36																																							
700.418	EDP-C50-250/255-42,6																																							
700.419	EDP-C50-250/264-42,6		KA-50-50																				J3	2"	1 1/4"	1800	1700	400	450	450	400	1550	250	550	1640	2245	405*	215	TK3	
700.420	EDP-CH50-315/291-65,3																																							
700.421	EDP-CH50-315/308-89,8																																							
			KB1-65-65																				J4	DN65	DN65	1300	1560	420	413	357	370	1160	140	460	1550	2175	405*	150	385	TK2
		KB1-65-65	J5	DN65	DN65	1450	1310	459	1549	2171	357	150	385	TK2																										
		KB1-65-65	J3	DN65	DN80	DN65	1450	1310	493	1583	2205	357	150	385	TK2																									
		KB1-65-65	J4	DN65	DN65	1800	1700	400	450	450	400	1550	250	595	1740	2345	357	215	TK4																					
		KB1-65-65	J5	DN65	DN65	1900	1650	595	1740	2345	357	215	TK5																											

\* Tolerance of ± 50 mm  
blue components: optional available on request

Dimensions of fuel tanks on p. 61

## Dimensions - Fire fighting units Series "EDP"

Fire fighting units with horizontal pumps back pull-out type  
1 Electric main pump + 1 Diesel main motorpump + 1 jockey pump

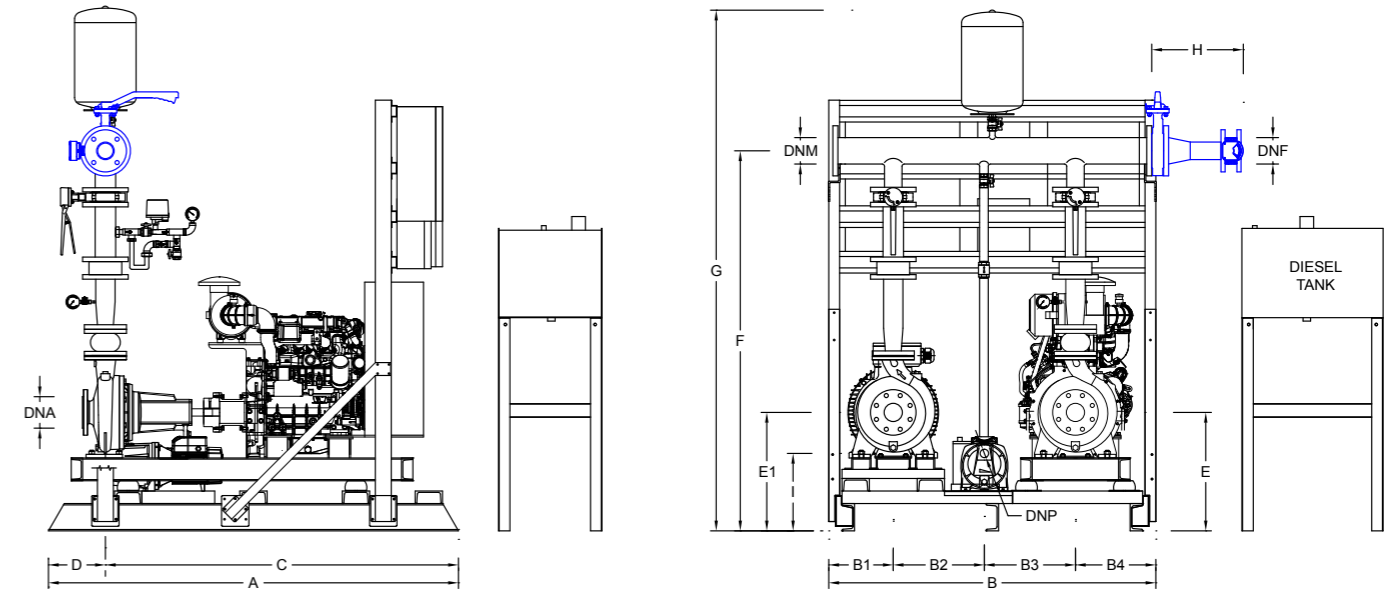

Units with capacity from m³/h 66 up to m³/h 360

Fire Fighting Unit		Flow meter kit	Jockey pump	Connections				Dimensions (mm)											Diesel Tank model	
Code	Model			DNA	DNM	DNF	DNP	A	B	B1	B2	B3	B4	C	D	E	E1	F		G
700.422	EDP-L65-200/187-24	KB2-100-65	J1	DN80	DN100	DN65	1300	1560	420	413	357	370	1160	140	460	1582	2218	397	367	TK2
700.423	EDP-S65-200N/192-36																			
700.424	EDP-L65-200/198-27																			
700.425	EDP-L65-200/210-36																			
700.426	EDP-S65-200N/215-42,6																			
700.427	EDP-L65-250/241-42,6																			
700.428	EDP-L65-250/258-50																			
700.429	EDP-S65-250N/222-42,6																			
700.430	EDP-S65-250N/245-65,3																			
700.431	EDP-S65-250N/255-65,3																			
700.432	EDP-S65-250N/259-65,3																			
700.433	EDP-S65-315R/273-89,8																			
700.434	EDP-S65-315R/282-89,8																			
700.435	EDP-L80-200/189-36	KB2-125-80	J1	DN80	DN125	DN80	1450	1560	420	413	357	370	1310	140	493	1685	2315	426	367	TK3
700.436	EDP-L80-200/207-42,5																			
700.437	EDP-L80-250/225-50																			
700.438	EDP-L80-250/238-65,3																			
700.439	EDP-L80-250/256-89,8																			
700.440	EDP-L80X-250/270-133,4																			
700.441	EDP-C80-200/205-65,3																			
700.442	EDP-C80-200/214-65,3																			
700.443	EDP-C80-250/235-65,3																			
700.444	EDP-C80-250/255-89,8																			
700.445	EDP-C80-250/264-133,4																			
700.446	EDP-S80-250/269-177,5*																			
700.447	EDP-S80-315R/302-177,5*																			

\* Supply on 2 different skids ( EP + D connected between with elastic compensator )  
blue components: optional available on request

Dimensions of fuel tanks on p. 61

## Dimensions - Fire fighting units Series "EDP"

Fire fighting units with horizontal pumps back pull-out type  
**1 Electric main pump + 1 Diesel main motorpump + 1 jockey pump**

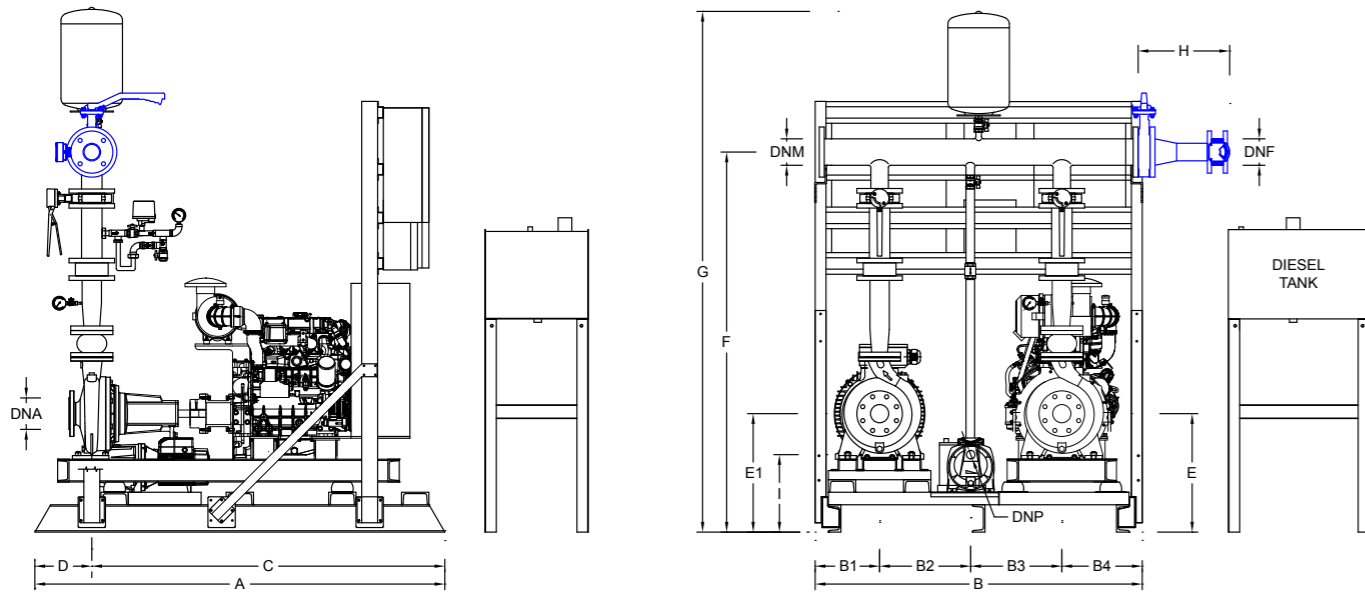

Units with capacity from m³/h 150 up to m³/h 750

Code	Fire Fighting Unit Model	Flow meter kit	Jockey pump	Connections				Dimensions (mm)													Diesel Tank model		
				DNA	DNM	DNF	DNP	A	B	B1	B2	B3	B4	C	D	E	E1	F	G	H		I	
700.448	EDP-L100-200/192-42,6	KC-150-125	J1	DN125	DN150	DN125	1"	1800	1700	400	450	450	400	1550	250	570	1851	2495	323	TK3			
700.449	EDP-L100-200/203-50		J2				2000	TK4															
700.450	EDP-L100-250/221-65,3		J3				1 1/4"	2200	1826	343	450	550	483	1950	595	1876	2520	215	TK6				
700.451	EDP-L100-250/235-89,8		J1				1"	2000	1700	400	450	450	400	1750	570	1851	2495	472	320	TK5			
700.452	EDP-L100-250/254-133,4		J2				1 1/4"	2200	1826	343	450	550	483	1950	595	1876	2520	215	TK6				
700.453	EDP-L100-250/267-133,4		J3				1 1/4"	2200	1826	343	450	550	483	1950	600	1881	2526	315	TK6				
700.454	EDP-S100-200A/219-89,8		J4				1"	2350	2435	523	410	745	757	2190	160	625	475	1941	2586	265	TK7		
700.455	EDP-S100-250CD/233-89,8		J5				1"	2000	1700	400	450	450	400	1750	570	1851	2495	472	320	TK5			
700.456	EDP-S100-250B/250-133,4		J1				1"	2000	1700	400	450	450	400	1750	570	1851	2495	472	320	TK5			
700.457	EDP-S100-250AB/265-133,4		J2				1 1/4"	2200	1826	343	450	550	483	1950	620	2072	2766	536	340	TK6			
700.458	EDP-S100-250A/269-133,4*	J3	1 1/4"	2450	2465	523	410	775	757	2340	225	665	2117	2812	438	536	265	340	TK7				
700.459	EDP-CH100-315/291-177,5*	J4	1 1/4"	2350																			
700.460	EDP-CH100-315/308-177,5*	J5	1 1/4"	2500	160	655	505	2107	2802	536	655	505	2107	2802	536	265	340	TK8					
700.461	EDP-L125-200/206-65,3	KC-200-150	J1	DN150	DN200	DN200	1"	2000	1700	400	450	450	400	1750	250	570	1982	2676	536	323	TK4		
700.462	EDP-L125-200/216-89,8		J2				2200	1826	343	450	550	483	1950	620	2072	2766	536	340	TK6				
700.463	EDP-CH125-250/222-89,8		J3				1 1/4"	2450	2225	225	665	2117	2812	438	536	265	340	TK7					
700.464	EDP-L125-270/224-133,4		J4				1 1/4"	2350	2190	160	625	475	2077	2772	438	536	265	340	TK7				
700.465	EDP-L125-270/237-133,4		J5				1 1/4"	2500	2340	160	655	505	2107	2802	536	655	505	2107	2802	536	265	340	TK8
700.466	EDP-L125-270/253-177,5*		J1				1"	2000	1700	400	450	450	400	1750	250	570	1982	2676	536	323	TK5		
700.467	EDP-CH125-250/264-177,5*		J2				1 1/4"	2450	2225	225	665	2117	2812	438	536	265	340	TK7					
700.468	EDP-L125-270/266-177,5*		J3				1 1/4"	2350	2190	160	625	475	2077	2772	438	536	265	340	TK7				
700.469	EDP-CH125-250/278-200,7*		J4				1 1/4"	2500	2340	160	655	505	2107	2802	536	655	505	2107	2802	536	265	340	TK8
700.470	EDP-S125-315R/302-242*		J5				1 1/4"	2500	2340	160	655	505	2107	2802	536	655	505	2107	2802	536	265	340	TK8
700.471	EDP-S150-315R/257-242*	J1	1"	2000	1700	400	450	450	400	1750	250	570	1982	2676	536	323	TK5						
700.472	EDP-S150-315R/266-242*	J2	1 1/4"	2450	2225	225	665	2117	2812	438	536	265	340	TK7									
700.473	EDP-S150-315R/280-272*	J3	1 1/4"	2350	2190	160	625	475	2077	2772	438	536	265	340	TK7								
700.474	EDP-S150-315R/290-302*	J4	1 1/4"	2500	2340	160	655	505	2107	2802	536	655	505	2107	2802	536	265	340	TK8				

\* Supply on 2 different skids ( EP + D connected between with elastic compensator )  
 blue components: optional available on request

Dimensions of fuel tanks on p. 61

## Jockey Pumps

Identification system of the jockey pumps listed in tables of the fire fighting units with back pull-out pumps type.

Table Ref.	Jockey pump model	Type	Q max (m³/h)	H max (mt)	Power kW
J 1	SW 15H	"Jet" self-priming	3	70	1.1
J 2	SW3AH	"Jet" self-priming	4.8	96	2.2
J 3	U5V-300/10T	Vertical	8.4	112	2.2
J 4	U5V-350/11T	Vertical	8.4	122	3
J 5	U7V-550/10T	Vertical	10.2	127	4

## Diesel tanks for fire fighting units with diesel motorpump

Identification system of the diesel tanks listed in tables

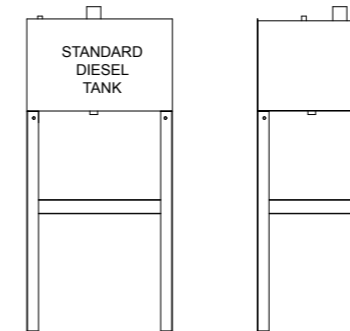

Diesel tanks dimensions (each motorpump is supplied with one separately tank)

Tank Model	Capacity lt	A mm	B mm	P mm
TK-1	15	1175	320	304
TK-2	25	1207	420	314
TK-3	50	1227	570	404
TK-4	75	1377	620	454
TK-5	100	1407	670	504
TK-6	125	1477	770	504
TK-7	160	1477	870	554
TK-8	230	1537	1070	554
TK-9	260	1557	1170	554
TK-10	285	1557	1170	554

# 4.1

Fire fighting units with bore hole (submersible) pumps, made according to standard EN 12845

## 1 Electric main pump + 1 jockey pump (wall fixing) "SP" Series

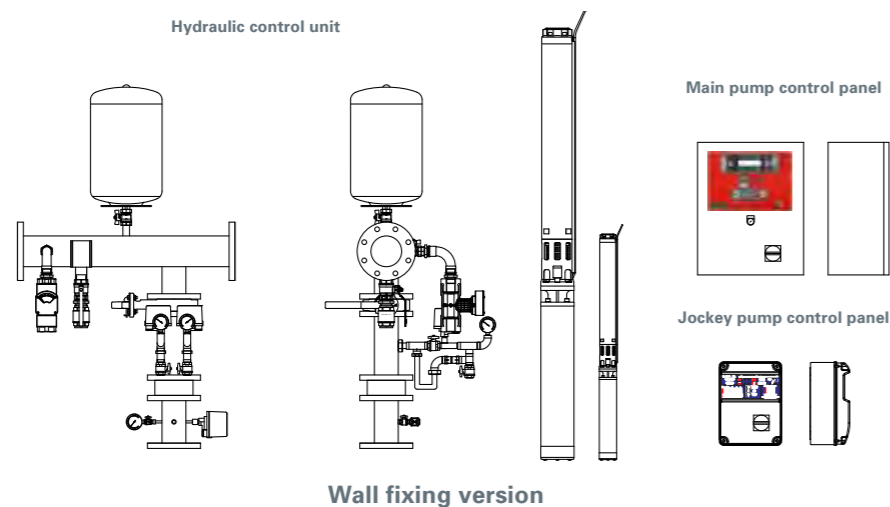

Wall fixing version

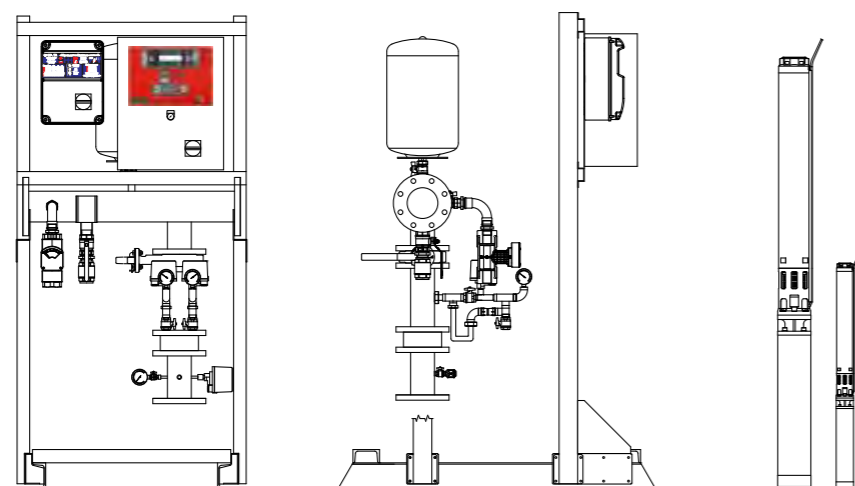

On skid version

Fire fighting unit according to standard EN 12845, consists of 1 electric submersible main pump + 1 submersible jockey pump:

Main pump of the bore hole type, with three-phase asynchronous electric motor. The fire fighting unit is complete with an electric main pump and a jockey pump of the submersible type (supplied separately), the hydraulic control unit with wall fixing system and electrical control panels supplied for wall fixing. The supply of the Fire fighting unit series "SP" as an option provides the ability to have the hydraulic control unit and electrical control panels mounted on one base in painted steel. The pumps are always supplied separately for installation in water tank and in some cases the installer must provide of the hydraulic/

motor coupling. All pumps in this catalog are designed for eventual horizontal installation. If the model of the fire fighting unit begins with "SP4-": the jockey pump is of the 4 " submergible type, it comes with 1.5 meters of cable and requires of the cooling jacket for a correct installation (see tables of components available on request ). If the model of the fire fighting unit starts with "SPM-": the jockey pump is of the 5" mono-block submergible type, it is provided with 15 meters of cable and does not require the cooling jacket.

Fire fighting units with bore hole (submersible) pumps, made according to standard EN 12845

## 1 Electric main pump + 1 jockey pump (wall fixing) "SP" Series

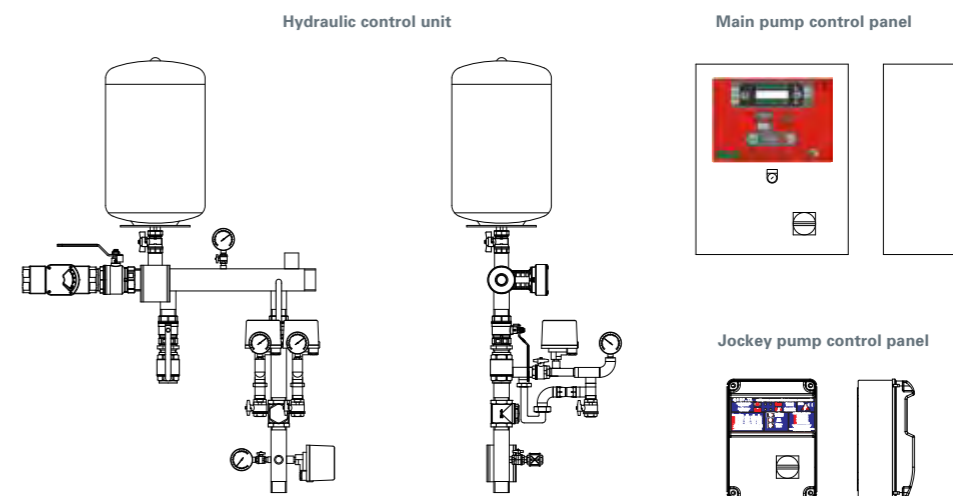

Units with capacity from m³/h 0 up to m³/h 18 (electric main pump 5" mono-block submersible type)

Code	Model	Electric Power (kW)	Q= CAPACITY OF EACH SERVICE PUMP									
			m³/h 0	2,1	4,2	6,3	7,2	9	12	14,4	18	
			l/m 0	35	70	105	120	150	200	240	300	
H= Total head ( m.c.a. )												
700.485	SP-P-K5-4/2-Q1,5	0.75+0.75	50	45	35*	21	14					
700.486	SP-P-K5-4/3-Q1,5	1.1+1.1	67	61	48*	27	18					
700.487	SP-P-K5-4/4-Q2	1.5+1.1	75	67	57*	40	32					
700.488	SP-P-K5-4/5-Q3	2.2+1.5	105	96	80*	56	44					
700.489	SP-S-M5-B/4-Q1,5	1.5+0.75	56	51	45	36*	32	19				
700.490	SP-S-M5-B/5-Q2	1.5+1.1	69	62	55	44*	38	20				
700.491	SP-S-M5-B/7-Q3	2.2+1.5	96	88	78	63*	55	30				
700.492	SP-S-M5-C/3-Q2	1.5+0.75	38		37	34	33	31	25*	16	7	
700.493	SP-S-M5-C/5-Q3	2.2+1.1	66		64	61	59	55	45*	32	15	
700.494	SP-S-M5-C/6-Q3	3+1.1	77		75	72	70	65	52*	37	19	
700.495	SP-S-M5-C/7-Q5,5	3.3+1.5	89		88	84	80	74	59*	42	20	
700.496	SP-S-M5-C/9-Q7,5	4+2.2	113		110	107	103	92	80*	56	27	

### Components on requires

Product Code	Model	Description
700.497	SKID-SP-1	Assembly of the hydraulic control unit and the electrical control panels on a painted steel skid (pumps supplied separately)

Tolerances in table: ISO 9906 Annex A (performance at the outlet of the pump)  
\* maximum efficiency point

This type of pump is supplied with 15 meters of cable and does not require the cooling jacket. Pumps, electrical control panels and hydraulic control unit are supplied separately.

Fire fighting units with bore hole (submersible) pumps, made according to standard EN 12845 Norma EN 12845

1 Electric main pump + 1 jockey pump (wall fixing)  
"SP" Series

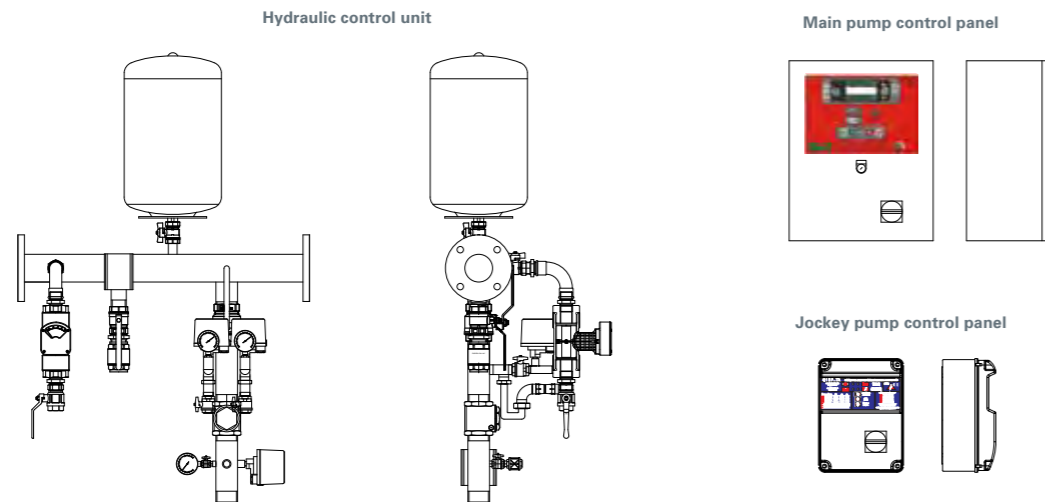

Units with capacity from m³/h 0 up to m³/h 25 (electric main pump 4" submersible type)

Code	Model	Electric Power (kW)	Q= CAPACITY OF EACH SERVICE PUMP															
			m³/h 0	5	6,3	7	8	9	10	11	12	14	16	18	20	22	24	
			l/m 0	83	105	117	133	150	167	183	200	233	267	300	333	367	400	
H= Total head ( m.c.a. )																		
700.498	SPm-S-NS95DA/8-O-Q2	1.5+0.75	52	46	43	41	38*	34	29	24								
700.499	SPm-S-NS95DA/10-O-Q5,5	2.2+1.1	65	58	54	51	47*	42	36	30								
700.500	SPm-S-NS95DA/13-O-Q5,5	2.2+1.1	85	75	70	67	61*	55	47	38								
700.501	SPm-S-FS98E/7-O-Q2	1.1+0.75	49				35	31*	26	19	13							
700.502	SPm-S-FS98E/9-O-Q2	1.5+0.75	62				45	40*	33	25	17							
700.503	SPm-S-FS98E/11-O-Q5,5	2.2+1.1	76				55	49*	40	30	20							
700.504	SPm-S-FS98E/13-O-Q5,5	2.2+1.5	88				65	58*	47	36	24							
700.505	SPm-R-4ES12/17-44F-Q5,5	3+2.2	108		91	83	76	68*	62	56	44							
700.506	SP4-R-4ES12/23-45F-Q7,5	4+1.5	148		125	118	110	100*	88	77	58							
700.507	SPm-R-4ES24/8-43N-Q4	2.2+0.75	51				42	40	38	35	34	31	26*	21	18	14	12	
700.508	SPm-R-4ES24/11-44F-Q5,5	3+1.1	70				58	56	54	50	48	44	39*	32	28	22	17	
700.509	SPm-R-4ES24/13-45F-Q7,5	4+1.1	81				68	64	62	59	57	51	46*	39	34	28	21	
700.510	SPm-R-4ES24/15-45F-Q7,5	4+2.2	97				80	76	74	71	68	61	56*	48	42	34	26	
700.511	SP4-R-4ES24/20-47F-Q10	5.5+1.1	125				104	100	96	92	88	79	72*	62	54	46	36	

Components on requires

Product Code	Model	Description
700.497	SKID-SP-1	Assembly of the hydraulic control unit and the electrical control panels on a painted steel skid (pumps supplied separately)
700.515	CAM-4"	Cooling jacket in galvanized steel, which is necessary for correct cooling of the submersible 4" pump; to install a cooling jacket for each main pump (supplied separately) To install one more for the jockey pump only if the model of fire fighting unit starts with "SP4-"

Tolerances in table: ISO 9906 Annex A (performance at the outlet of the pump)  
\* maximum efficiency point

This type of fire fighting units mounted electric main pumps of the 4" submersible type, which are supplied with 1.5 meters of cable and require of the cooling jacket for a correct installation.

Fire fighting units with bore hole (submersible) pumps, made according to standard EN 12845

1 Electric main pump + 1 jockey pump (wall fixing)  
"SP" Series

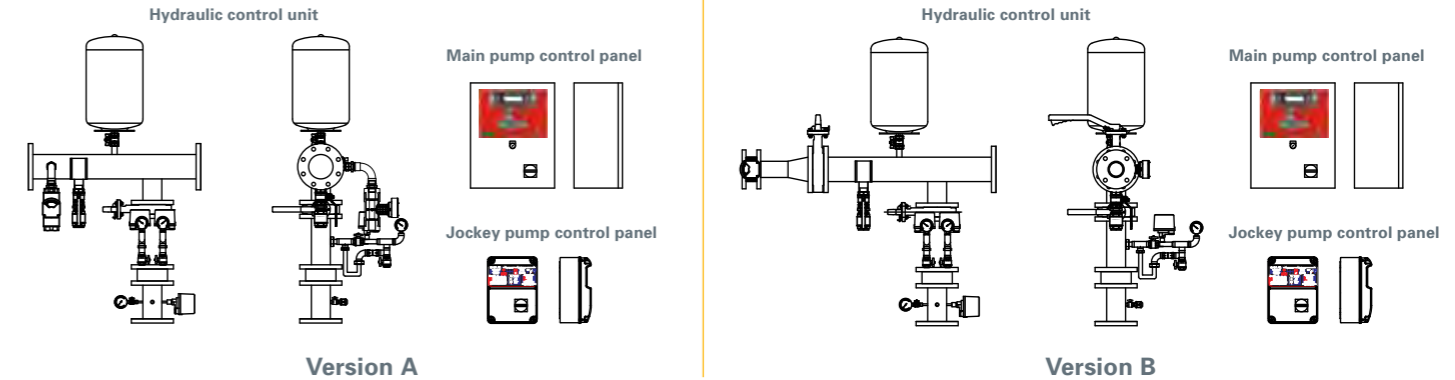

Units with capacity from m³/h 21.6 up to m³/h 90 (electric main pump 6" submersible type)

Code	Model	Electric Power (kW)	Q= CAPACITY OF EACH SERVICE PUMP														
			m³/h 0	21,6	27	28,8	30	36	43,2	48	50,4	56	60	72	84	90	
			l/m 0	360	450	480	500	600	720	800	840	933	1000	1200	1400	1500	
H= Total head ( m.c.a. )																	
700.516	SPm-S-NR151F/4-O-Q7,5	3+0.75	46	34*	26	21	18.3										
700.517	SPm-S-NR151F/6-O-Q10	4+1.1	69	50*	38	31	28.5										
700.518	SPm-S-NR151F/8-O-Q10	5.5+1.5	92	67*	50	42	38										
700.519	SP4-S-NR151F/11-O-Q12,5	7.5+1.1	127	90*	68	57	52										
700.520	SPm-S-NR151E/3A-A-Q7,5	4+0.75	42	37	36	35	35*	30	22	16							
700.521	SPm-S-NR151E/4-O-Q10	5.5+0.75	59	51	48	47	46*	40	29	22							
700.522	SPm-S-NR151E/6B-O-Q12,5	7.5+1.1	81	73	71	68	67*	55	40	28							
700.523	SPm-S-NR151E/7B-O-Q12,5	9.2+1.5	94	86	82	80	78*	65	58	33							
700.524	SP4-S-NR151E/8-O-Q20	11+1.1	117	103	98	95	93*	79	59	41							
700.525	SPm-S-NR152D/4-O-Q12,5	7.5+0.75	63			50	48	42*	32	25	20	12					
700.526	SPm-S-NR152D/5-O-Q12,5	9.2+1.1	79			63	60	52*	42	32	25	15					
700.527	SPm-S-NR152D/6-O-Q12,5	9.2+2.2	95			75	72	61*	48	38	28	18					
700.528	SPm-S-NR152D/7-O-Q20	11+2.2	111			88	84	71*	52	44	34	21					
700.529	SP4-S-NR152D/8-O-Q20	13+1.1	127			100	96	82*	61	50	39	24					
700.530	SP4-S-NR152D/9-O-Q20	15+1.5	142			113	108	92*	70	57	44	27					
700.531	SP4-S-S151A/8-O-Q20	15+1.5	137			108	106	98	88*	77	72	61	48				
700.532	SPm-S-S151B/3-O-Q12,5	7.5+0.75	50					40	37	34	33	30*	29	20			
700.533	SPm-S-S151B/4-O-Q12,5	9.2+1.1	66					42	49	44	43	40*	37	26			
700.534	SPm-S-S151B/5-O-Q20	11+1.1	83					63	59	56	54	50*	46	33			
700.535	SPm-S-S151B/6-O-Q20	13+2.2	99					77	72	68	68	60*	57	39			
700.536	SP4-S-S151B/7-O-Q20	15+1.1	116					89	85	80	78	70*	67	46			
700.537	SP4-S-S151B/8-A-Q30	18.5+1.5	132					102	97	90	88	80*	75	52			
700.538	SPm-S-S151C/4-O-Q20	11+1.1	64									42	41	34*	25	20	
700.539	SPm-S-S151C/5-O-Q20	13+1.1	80									53	52	43*	32	24	
700.540	SPm-S-S151C/6A-OL-Q20	15+2.2	95									62	60	50*	36	27	
700.541	SPm-R-6EC4/9-622-F-Q25	16.5+2.2	109									70	65	52*	39	22	
700.542	SP4-R-6EC4/10-625-F-Q30	18.5+1.1	121									77	72	58*	43	36	
700.543	SP4-R-6EC4/11-627-F-Q30	20+1.5	133									85	79	64*	49	41	
700.544	SP4-R-6EC4/12-630-F-Q30	22+1.5	145									92	86	70*	53	45	
700.545	SP4-S-S151C/9-A-Q40	26+1.5	144									95	92	77*	56	44	

Components on requires

Product Code	Model	Description
700.497	SKID-SP-1	Assembly of the hydraulic control unit and the electrical control panels on a painted steel skid (pumps supplied separately)
700.546	CAM-6"	Cooling jacket in galvanized steel, which is necessary for correct cooling of the submersible 6" main pump; to install a cooling jacket for each main pump (supplied separately)
700.515	CAM-4"	Cooling jacket in galvanized steel, which is necessary for correct cooling of the 4" jockey pump; to install only if the model of fire fighting unit begins with "SP4"

Tolerances in table: ISO 9906 Annex A (performance at the outlet of the pump)  
\* maximum efficiency point

This type of fire fighting units mounted electric main pumps of the 6" submersible type, which are supplied with 1.5 meters of cable and require of the cooling jacket for a correct installation.



## Dimensions - Fire fighting units Series "SP"

Fire fighting units with bore hole 5" mono-block pumps  
1 Electric main pump + 1 jockey pump (wall fixing)

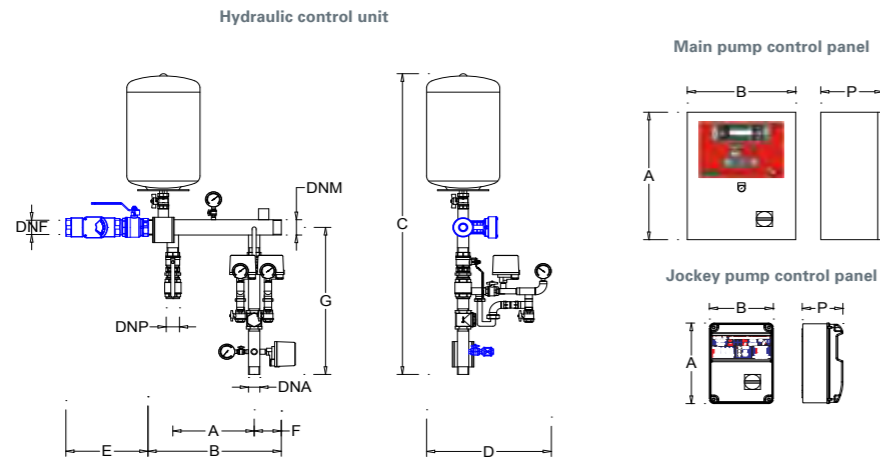

Units with capacity from m<sup>3</sup>/h 0 up to m<sup>3</sup>/h 18 (electric main pump 5" mono-block submersible type)

Fire Fighting Unit		Flow meter kit	Jockey Pump	Connections				Hydraulic control unit (mm)							main pump control panel (mm)			jockey pump control panel (mm)		
Code	Model			DNA	DNM	DNF	DNP	A	B	C	D	E	F	G	A	B	P	A	B	P
700.485	SP-P-K5-4/2-Q1,5	KA-25-25	S1	1 1/4" M	2" M	1" F	1 1/4" F	300	500	1180*	460	295*	100	580	500	400	230	316	240	150
700.486	SP-P-K5-4/3-Q1,5		S2																	
700.487	SP-P-K5-4/4-Q2		S3																	
700.488	SP-P-K5-4/5-Q3		S1																	
700.489	SP-S-M5-B/4-Q1,5		S2																	
700.490	SP-S-M5-B/5-Q2		S3																	
700.491	SP-S-M5-B/7-Q3		S1																	
700.492	SP-S-M5-C/3-Q2		S2																	
700.493	SP-S-M5-C/5-Q3		S3																	
700.494	SP-S-M5-C/6-Q3		S1																	
700.495	SP-S-M5-C/7-Q5,5		S2																	
700.496	SP-S-M5-C/9-Q7,5		S3																	
			S4																	

\* Tolerance of ± 50 mm  
blue components: optional available on request

## Dimensions - Fire fighting units Series "SP"

Fire fighting units with bore hole 5" mono-block pumps  
1 Electric main pump + 1 jockey pump (on skid)

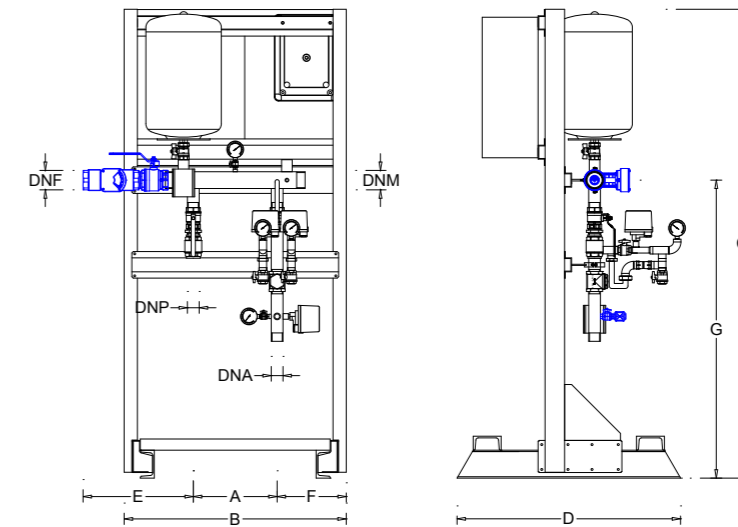

Units with capacity from m<sup>3</sup>/h 0 up to m<sup>3</sup>/h 18 (electric main pump 5" mono-block submersible type)

Fire Fighting Unit		Flow meter kit	Jockey Pump	Connections				Dimensions (mm)						
Code	Model			DNA	DNM	DNF	DNP	A	B	C	D	E	F	G
700.485+700.497	SP-P-K5-4/2-Q1,5+SKID-SP-1	KA-25-25	S1	1 1/4" M	2" M	1" F	1 1/4" F	300	795	1678	800	395*	248	1067
700.486+700.497	SP-P-K5-4/3-Q1,5+SKID-SP-1		S2											
700.487+700.497	SP-P-K5-4/4-Q2+SKID-SP-1		S3											
700.488+700.497	SP-P-K5-4/5-Q3+SKID-SP-1		S1											
700.489+700.497	SP-S-M5-B/4-Q1,5+SKID-SP-1		S2											
700.490+700.497	SP-S-M5-B/5-Q2+SKID-SP-1		S3											
700.491+700.497	SP-S-M5-B/7-Q3+SKID-SP-1		S1											
700.492+700.497	SP-S-M5-C/3-Q2+SKID-SP-1		S2											
700.493+700.497	SP-S-M5-C/5-Q3+SKID-SP-1		S3											
700.494+700.497	SP-S-M5-C/6-Q3+SKID-SP-1		S1											
700.495+700.497	SP-S-M5-C/7-Q5,5+SKID-SP-1		S2											
700.496+700.497	SP-S-M5-C/9-Q7,5+SKID-SP-1		S3											
			S4											

\* Tolerance of ± 50 mm  
blue components: optional available on request

## Dimensions - Fire fighting units Series "SP"

Fire fighting units with bore hole 4" pumps  
1 Electric main pump + 1 jockey pump (wall fixing)

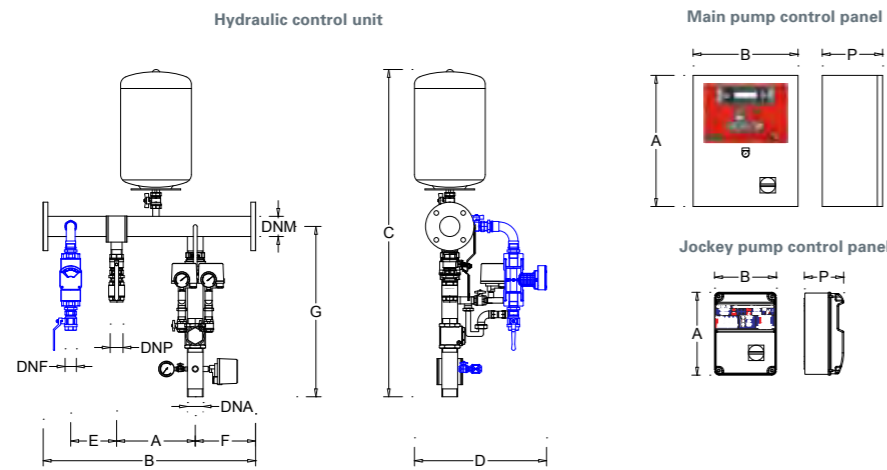

Units with capacity from m<sup>3</sup>/h 0 up to m<sup>3</sup>/h 25 (electric main pump 4" submersible type)

Fire Fighting Unit		Flow meter kit	Jockey Pump	Connections				Hydraulic control unit (mm)						main pump control panel (mm)			jockey pump control panel (mm)			
Code	Model			DNA	DNM	DNF	DNP	A	B	C	D	E	F	G	A	B	P	A	B	P
700.498	SPm-S-NS95DA/8-O-Q2	KA-25-25	S1	2" M	DN65	1" F	1 1/4" F	300	810	1248*	505*	175	230	650	500	400	230	316	240	150
700.499	SPm-S-NS95DA/10-O-Q5,5		S2																	
700.500	SPm-S-NS95DA/13-O-Q5,5		S1																	
700.501	SPm-S-FS98E/7-O-Q2																			
700.502	SPm-S-FS98E/9-O-Q2		S2																	
700.503	SPm-S-FS98E/11-O-Q5,5																			
700.504	SPm-S-FS98E/13-O-Q5,5		S3																	
700.505	SPm-R-4ES12/17-44F-Q5,5		S4																	
700.506	SP4-R-4ES12/23-45F-Q7,5		S6																	
700.507	SPm-R-4ES24/8-43N-Q4		S1																	
700.508	SPm-R-4ES24/11-44F-Q5,5		S2																	
700.509	SPm-R-4ES24/13-45F-Q7,5																			
700.510	SPm-R-4ES24/15-45F-Q7,5		S4																	
700.511	SP4-R-4ES24/20-47F-Q10		S5																	

\* Tolerance of ± 50 mm  
blue components: optional available on request

## Dimensions - Fire fighting units Series "SP"

Fire fighting units with bore hole 4" pumps  
1 Electric main pump + 1 jockey pump (on skid)

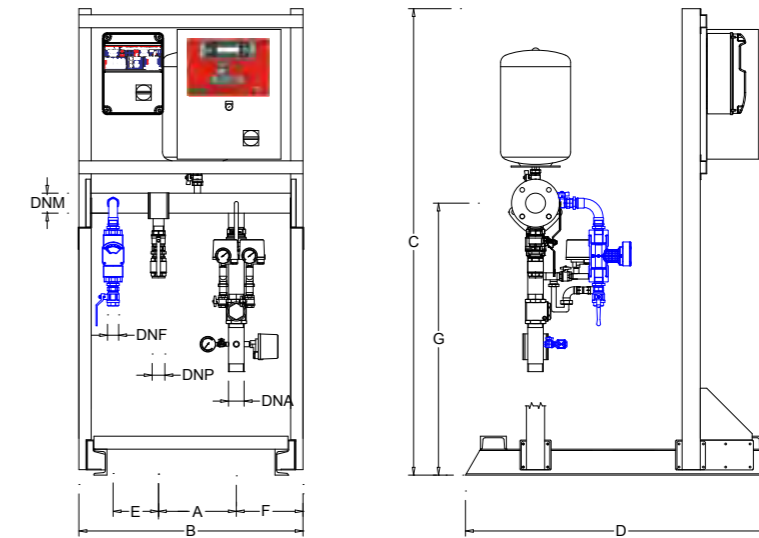

Units with capacity from m<sup>3</sup>/h 0 up to m<sup>3</sup>/h 25 (electric main pump 4" submersible type)

Fire Fighting Unit		Flow meter kit	Jockey Pump	Connections				Dimensions (mm)						
Code	Model			DNA	DNM	DNF	DNP	A	B	C	D	E	F	G
700.498+700.497	SPm-S-NS95DA/8-O-Q2+SKID-SP-1	KA-25-25	S1	2" M	DN65	1" F	1 1/4" F	300	864	1647	1200	175	257	1048
700.499+700.497	SPm-S-NS95DA/10-O-Q5,5+SKID-SP-1		S2											
700.500+700.497	SPm-S-NS95DA/13-O-Q5,5+SKID-SP-1		S1											
700.501+700.497	SPm-S-FS98E/7-O-Q2+SKID-SP-1													
700.502+700.497	SPm-S-FS98E/9-O-Q2+SKID-SP-1		S2											
700.503+700.497	SPm-S-FS98E/11-O-Q5,5+SKID-SP-1													
700.504+700.497	SPm-S-FS98E/13-O-Q5,5+SKID-SP-1		S3											
700.505+700.497	SPm-R-4ES12/17-44F-Q5,5+SKID-SP-1		S4											
700.506+700.497	SP4-R-4ES12/23-45F-Q7,5+SKID-SP-1		S6											
700.507+700.497	SPm-R-4ES24/8-43N-Q4+SKID-SP-1		S1											
700.508+700.497	SPm-R-4ES24/11-44F-Q5,5+SKID-SP-1		S2											
700.509+700.497	SPm-R-4ES24/13-45F-Q7,5+SKID-SP-1													
700.510+700.497	SPm-R-4ES24/15-45F-Q7,5+SKID-SP-1		S4											
700.511+700.497	SP4-R-4ES24/20-47F-Q10+SKID-SP-1		S5											

\* Tolerance of ± 50 mm  
blue components: optional available on request

## Dimensions - Fire fighting units Series "SP"

Fire fighting units with bore hole 6" pumps  
1 Electric main pump + 1 jockey pump (wall fixing)

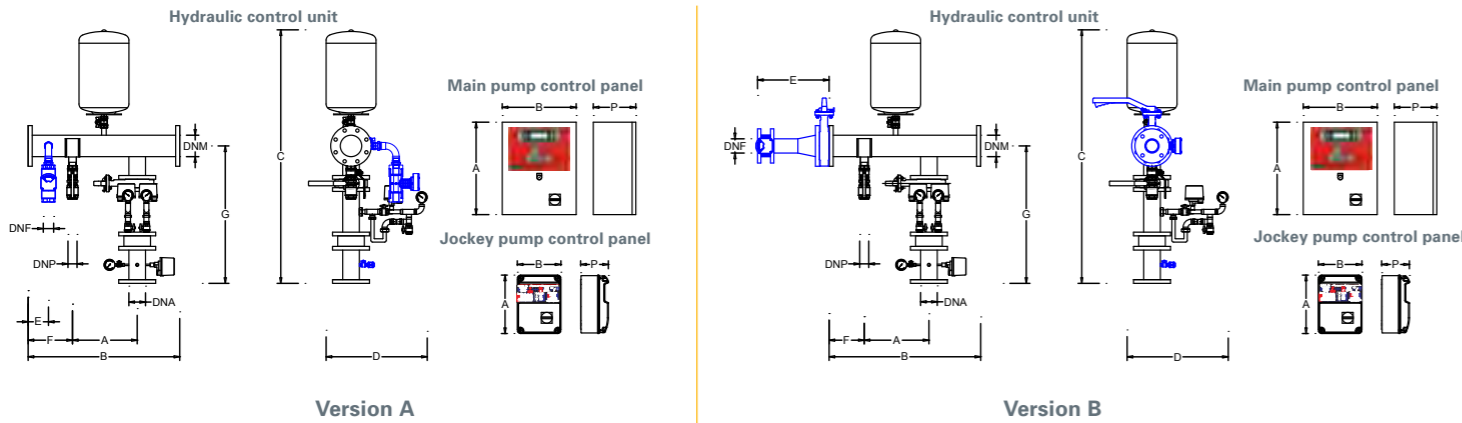

## Dimensions - Fire fighting units Series "SP"

Fire fighting units with bore hole 6" pumps  
1 Electric main pump + 1 jockey pump (on skid)

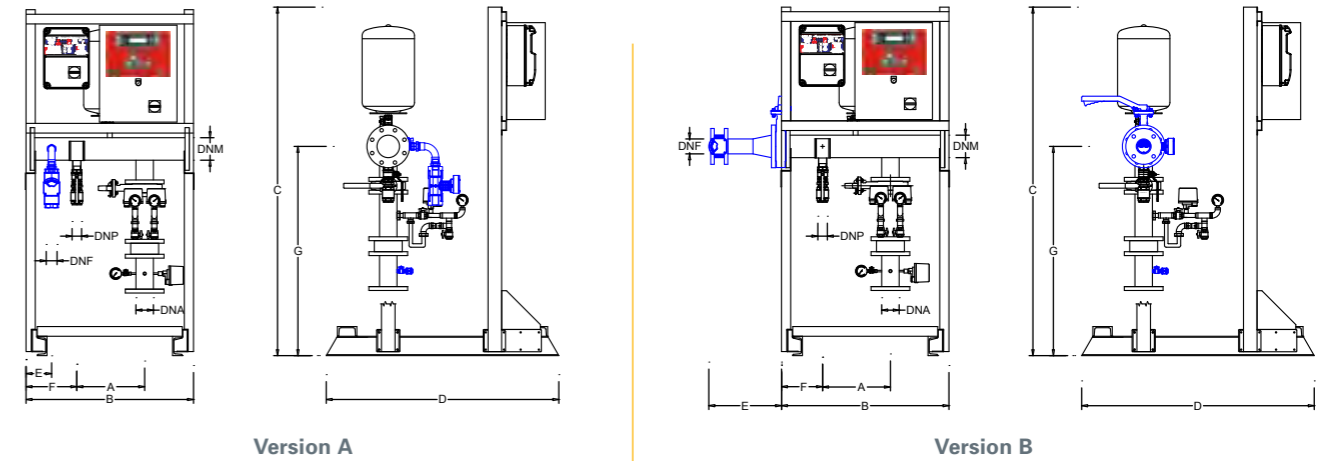

Units with capacity from m<sup>3</sup>/h 21.6 up to m<sup>3</sup>/h 90 (electric main pump 6" submersible type)

Fire Fighting Unit		Flow meter kit	Jockey Pump	Connections				Hydraulic control unit (mm)								main pump control panel (mm)			jockey pump control panel (mm)		
Codice Prodotto	Modello Gruppo Antincendio			DNA	DNM	DNF	DNP	A	B	C	D	Version A		Version B		A	B	P	A	B	P
												E	F	E	F						
700.516	SPm-S-NR151F/4-O-Q7,5	KA-40-40	S1	DN65	DN80									500	400						
700.517	SPm-S-NR151F/6-O-Q10		S2																		
700.518	SPm-S-NR151F/8-O-Q10		S3																		
700.519	SP4-S-NR151F/11-O-Q12,5		S5																		
700.520	SPm-S-NR151E/3A-A-Q7,5		S1																		1 1/2" F
700.521	SPm-S-NR151E/4-O-Q10	S2																			
700.522	SPm-S-NR151E/6B-O-Q12,5	S3																			
700.523	SPm-S-NR151E/7B-O-Q12,5	S5																			
700.524	SP4-S-NR151E/8-O-Q20	S1																			
700.525	SPm-S-NR152D/4-O-Q12,5	S2	KA-50-50	DN80	DN100									700	500	230					
700.526	SPm-S-NR152D/5-O-Q12,5	S4																			
700.527	SPm-S-NR152D/6-O-Q12,5	S5																			
700.528	SPm-S-NR152D/7-O-Q20	S6																			
700.529	SP4-S-NR152D/8-O-Q20	S1																			2" F
700.530	SP4-S-NR152D/9-O-Q20	S2																			
700.531	SPm-S-S151A/8-O-Q20	S4																			
700.532	SPm-S-S151B/3-O-Q12,5	S5																			
700.533	SPm-S-S151B/4-O-Q12,5	S6																			
700.534	SPm-S-S151B/5-O-Q20	S1	KB2-100-65											800	600	330					
700.535	SPm-S-S151B/6-O-Q20	S2																			
700.536	SP4-S-S151B/7-O-Q20	S4																			
700.537	SP4-S-S151B/8-A-Q30	S5																			
700.538	SPm-S-S151C/4-O-Q20	S6																			
700.539	SPm-S-S151C/5-O-Q20	S1	DN65																		
700.540	SPm-S-S151C/6A-OL-Q20	S2																			
700.541	SPm-R-6EC4/9-622-F-Q25	S4																			
700.542	SP4-R-6EC4/10-625-F-Q30	S5																			
700.543	SP4-R-6EC4/11-627-F-Q30	S6																			
700.544	SP4-R-6EC4/12-630-F-Q30	S1	KB2-100-65																		
700.545	SP4-S-S151C/9-A-Q40	S2																			
		S4																			
		S5																			
		S6																			

\* Tolerance of ± 50 mm  
blue components: optional available on request

Pumps, electrical control panels and hydraulic control unit are supplied separately.

Units with capacity from m<sup>3</sup>/h 21.6 up to m<sup>3</sup>/h 90 (electric main pump 6" submersible type)

Fire Fighting Unit		Flow meter kit	Jockey Pump	Connections				Dimension (mm)												
Code	Model			DNA	DNM	DNF	DNP	A	B	C	D	Version A		Version B		G				
												E	F	E	F					
700.516+700.497	SPm-S-NR151F/4-O-Q7,5+SKID-SP-1	KA-40-40	S1	DN65	DN80															
700.517+700.497	SPm-S-NR151F/6-O-Q10+SKID-SP-1		S2																	
700.518+700.497	SPm-S-NR151F/8-O-Q10+SKID-SP-1		S3																	
700.519+700.497	SP4-S-NR151F/11-O-Q12,5+SKID-SP-1		S5																	
700.520+700.497	SPm-S-NR151E/3A-A-Q7,5+SKID-SP-1		S1																	
700.521+700.497	SPm-S-NR151E/4-O-Q10+SKID-SP-1	S2																		
700.522+700.497	SPm-S-NR151E/6B-O-Q12,5+SKID-SP-1	S3																		
700.523+700.497	SPm-S-NR151E/7B-O-Q12,5+SKID-SP-1	S5																		
700.524+700.497	SP4-S-NR151E/8-O-Q20+SKID-SP-1	S1																		
700.525+700.497	SPm-S-NR152D/4-O-Q12,5+SKID-SP-1	S2	KA-50-50	DN80	DN100															
700.526+700.497	SPm-S-NR152D/5-O-Q12,5+SKID-SP-1	S4																		
700.527+700.497	SPm-S-NR152D/6-O-Q12,5+SKID-SP-1	S5																		
700.528+700.497	SPm-S-NR152D/7-O-Q20+SKID-SP-1	S6																		
700.529+700.497	SP4-S-NR152D/8-O-Q20+SKID-SP-1	S1																		
700.530+700.497	SP4-S-S151A/8-O-Q20+SKID-SP-1	S2																		
700.531+700.497	SPm-S-S151B/3-O-Q12,5+SKID-SP-1	S4																		
700.532+700.497	SPm-S-S151B/4-O-Q12,5+SKID-SP-1	S5																		
700.533+700.497	SPm-S-S151B/5-O-Q20+SKID-SP-1	S6																		
700.534+700.497	SPm-S-S151B/6-O-Q20+SKID-SP-1	S1	KB2-100-65																	
700.535+700.497	SPm-S-S151B/7-O-Q20+SKID-SP-1	S2																		
700.536+700.497	SP4-S-S151B/8-A-Q30+SKID-SP-1	S4																		
700.537+700.497	SPm-S-S151C/4-O-Q20+SKID-SP-1	S5																		
700.538+700.497	SPm-S-S151C/5-O-Q20+SKID-SP-1	S6																		
700.539+700.497	SPm-S-S151C/6A-OL-Q20+SKID-SP-1	S1	DN65																	
700.540+700.497	SPm-R-6EC4/9-622-F-Q25+SKID-SP-1	S2																		
700.541+700.497	SP4-R-6EC4/10-625-F-Q30+SKID-SP-1	S4																		
700.542+700.497	SP4-R-6EC4/11-627-F-Q30+SKID-SP-1	S5																		
700.543+700.497	SP4-R-6EC4/12-630-F-Q30+SKID-SP-1	S6																		
700.544+700.497	SP4-S-S151C/9-A-Q40+SKID-SP-1	S1	KB2-100-65																	
700.545+700.497	SP4-S-S151C/9-A-Q40+SKID-SP-1	S2																		
		S4																		
		S5																		
		S6																		

\* Tolerance of ± 50 mm  
blue components: optional available on request

The pumps are supplied separately

## Dimensions - Fire fighting units Series "SP"

Fire fighting units with bore hole 8-10" pumps  
1 Electric main pump + 1 jockey pump (wall fixing)

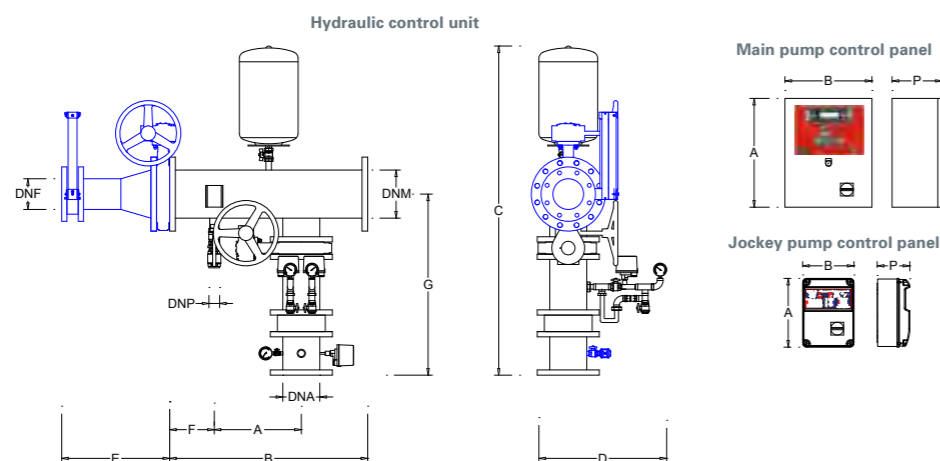

Units with capacity from m<sup>3</sup>/h 72 up to m<sup>3</sup>/h 280 (electric main pump 8" and 10" submersible type)

Fire Fighting Unit		Flow meter kit	Jockey Pump	Connections				Hydraulic control unit (mm)							main pump control panel (mm)			jockey pump control panel (mm)						
Code	Model			DNA	DNM	DNF	DNP	A	B	C	D	E	F	G	A	B	P	A	B	P				
700.547	SPm-R-8E2N/3F-615-F-Q20	KB2-150-80	S2	DN125	DN150	DN80	1447*	580	792	421	205	792	700	500	230	316	240	150						
700.548	SPm-R-8E2N-3E-617-F-Q20																							
700.549	SPm-R-8E2N/3B-620-F-Q25																							
700.550	SPm-R-8E2N/4EF-622-F-Q25																							
700.551	SPm-R-8E2N/4D-625-F-Q30																							
700.552	SPm-R-8E2N/4B-627-F-Q30																							
700.553	SP4-R-8E2N/5E-630-F-Q30		S3																					
700.554	SP4-R-8E2N/5A-635-F-Q40																							
700.555	SP4-R-8E2N/6E-635-F-Q40																							
700.556	SP4-R-8E2N/6B-640-F-Q50																							
700.557	SPm-S-S181B/2A-O-Q20												KC-150-100	S1	DN100				1 1/4" F	400	910	465	832	330
700.558	SPm-S-S181B/2-O-Q20																							
700.559	SPm-S-S181B/3A-A-Q30																							
700.560	SPm-S-S181B/3-A-Q30																							
700.561	SP4-S-S181B/4-A-Q40																							
700.562	SP4-S-S181B/5-A-Q50																							
700.563	SPm-S-S181D/2-A-Q30	S2																						
700.564	SPm-S-S181D/3-A-Q40																							
700.565	SP4-S-S181D/4-A-Q50																							
700.566	SP4-S-S181D/5-A-Q75																							
700.567	SPm-R-10E2N/2I-635-F-Q40		KC-200-125	S2	DN150	DN200	DN125	1512	622	536	832													
700.568	SPm-R-10E2N/2G-640-F-Q50																							
700.569	SPm-R-10E2N/2D-850-N-Q60																							
700.570	SP4-R-10E2N/3H-860-N-Q60																							
700.571	SPm-S-S252A/2-A-Q75																							
700.572	SP4-R-10E2N/3D-875-F-Q75																							
700.573	SP4-S-S252A/3B-A-Q100	S4																						
700.574	SP4-S-S252A/3-A-Q150																							

\* Tolerance of ± 50 mm  
 blue components: optional available on request

## Dimensions - Fire fighting units Series "SP"

Fire fighting units with bore hole 8-10" pumps  
1 Electric main pump + 1 jockey pump (on skid)

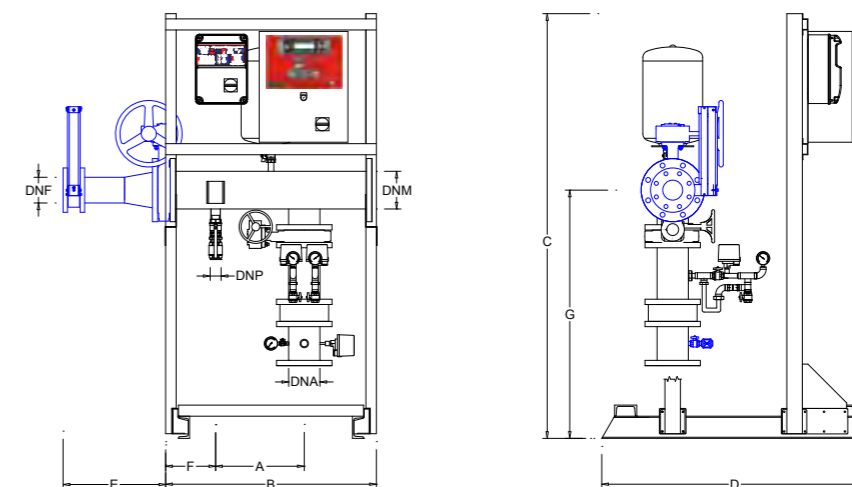

Units with capacity from m<sup>3</sup>/h 72 up to m<sup>3</sup>/h 280 (electric main pump 8" and 10" submersible type)

Fire Fighting Unit		Flow meter kit	Jockey Pump	Connections				Dimensions (mm)															
Code	Model			DNA	DNM	DNF	DNP	A	B	C	D	E	F	G									
700.547+700.497	SPm-R-8E2N/3F-615-F-Q20+SKID-SP-1	KB2-150-80	S2	DN125	DN150	DN80	1775	1230	428	792	205	792	316	240	150								
700.548+700.497	SPm-R-8E2N-3E-617-F-Q20+SKID-SP-1																						
700.549+700.497	SPm-R-8E2N/3B-620-F-Q25+SKID-SP-1																						
700.550+700.497	SPm-R-8E2N/4EF-622-F-Q25+SKID-SP-1																						
700.551+700.497	SPm-R-8E2N/4D-625-F-Q30+SKID-SP-1																						
700.552+700.497	SPm-R-8E2N/4B-627-F-Q30+SKID-SP-1																						
700.553+700.497	SP4-R-8E2N/5E-630-F-Q30+SKID-SP-1		S3																				
700.554+700.497	SP4-R-8E2N/5A-635-F-Q40+SKID-SP-1																						
700.555+700.497	SP4-R-8E2N/6E-635-F-Q40+SKID-SP-1																						
700.556+700.497	SP4-R-8E2N/6B-640-F-Q50+SKID-SP-1																						
700.557+700.497	SPm-S-S181B/2A-O-Q20+SKID-SP-1															KC-150-100	S1	DN100	1 1/4" F	400	951	483	832
700.558+700.497	SPm-S-S181B/2-O-Q20+SKID-SP-1																						
700.559+700.497	SPm-S-S181B/3A-A-Q30+SKID-SP-1																						
700.560+700.497	SPm-S-S181B/3-A-Q30+SKID-SP-1																						
700.561+700.497	SP4-S-S181B/4-A-Q40+SKID-SP-1																						
700.562+700.497	SP4-S-S181B/5-A-Q50+SKID-SP-1																						
700.563+700.497	SPm-S-S181D/2-A-Q30+SKID-SP-1	S2																					
700.564+700.497	SPm-S-S181D/3-A-Q40+SKID-SP-1																						
700.565+700.497	SP4-S-S181D/4-A-Q50+SKID-SP-1																						
700.566+700.497	SP4-S-S181D/5-A-Q75+SKID-SP-1																						
700.567+700.497	SPm-R-10E2N/2I-635-F-Q40+SKID-SP-1		KC-200-125	S2	DN150	DN200	DN125	1512	1260	501													
700.568+700.497	SPm-R-10E2N/2G-640-F-Q50+SKID-SP-1																						
700.569+700.497	SPm-R-10E2N/2D-850-N-Q60+SKID-SP-1																						
700.570+700.497	SP4-R-10E2N/3H-860-N-Q60+SKID-SP-1																						
700.571+700.497	SPm-S-S252A/2-A-Q75+SKID-SP-1																						
700.572+700.497	SP4-R-10E2N/3D-875-F-Q75+SKID-SP-1																						
700.573+700.497	SP4-S-S252A/3B-A-Q100+SKID-SP-1	S4																					
700.574+700.497	SP4-S-S252A/3-A-Q150+SKID-SP-1																						

\* Tolerance of ± 50 mm  
 blue components: optional available on request

# Control panels supplied separately, dimensions in the table above

# 4.2

Fire fighting units with bore hole (submersible) pumps, made according to standard EN 12845

## 2 Electric main pump + 1 jockey pump (wall fixing) "2SP" Series

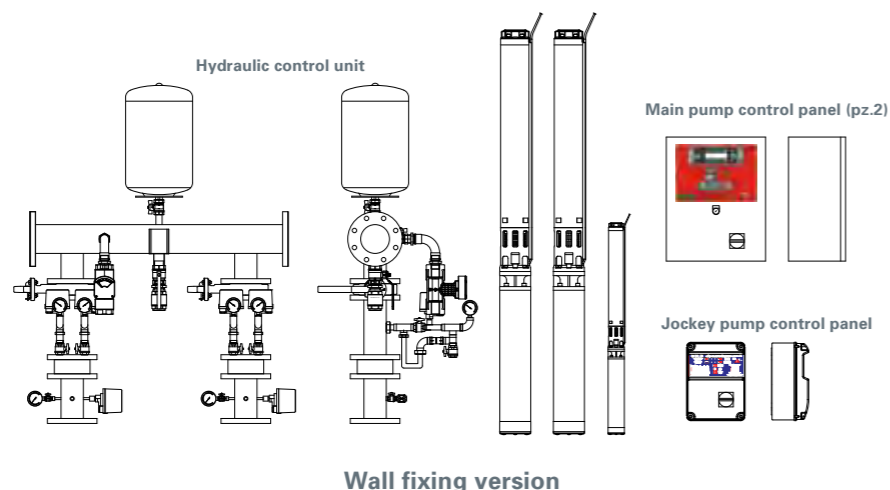

Wall fixing version

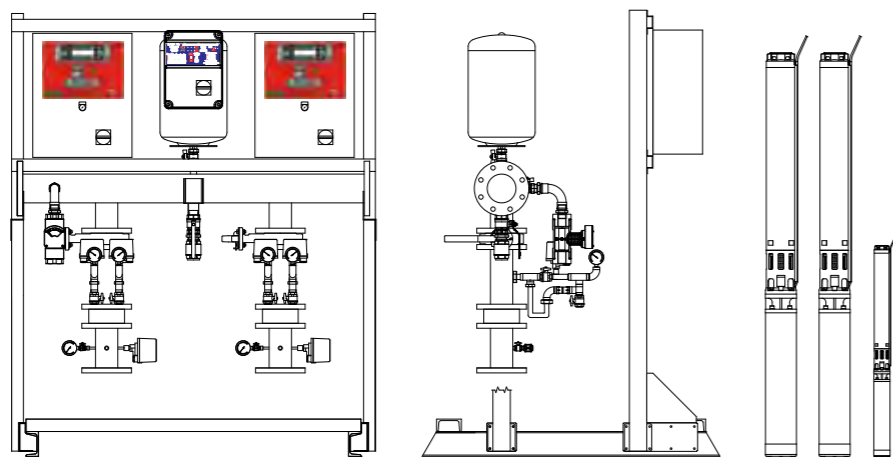

On skid version

Fire fighting unit according to standard EN 12845, consists of 2 electric submersible main pump + 1 submersible jockey pump:

Main pumps of the bore hole type, with three-phase asynchronous electric motor. The fire fighting unit is complete with 2 electric main pumps and 1 jockey pump of the submersible type (supplied separately), the hydraulic control unit with wall fixing system and electrical control panels supplied for wall fixing. The supply of the Fire fighting unit series "SP" as an option provides the ability to have the hydraulic control unit and electrical control panels mounted on one base in painted steel. The pumps are always supplied separately for installation in water

tank and in some cases the installer must provide of the hydraulic/ motor coupling. All pumps in this catalog are designed for eventual horizontal installation. If the model of the fire fighting unit begins with "SP4-": the jockey pump is of the 4 " submersible type, it comes with 1.5 meters of cable and requires of the cooling jacket for a correct installation (see tables of components available on request ). If the model of the fire fighting unit starts with "SPM-": the jockey pump is of the 5" mono-block submersible type, it is provided with 15 meters of cable and does not require the cooling jacket.

Fire fighting units with bore hole (submersible) pumps, made according to standard EN 12845

## 2 Electric main pump + 1 jockey pump (wall fixing) "2SP" Series

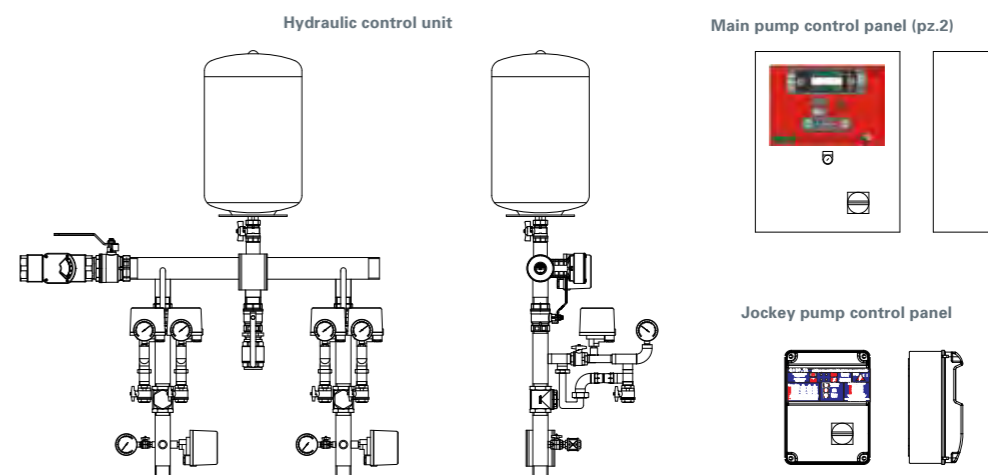

Units with capacity from m³/h 0 up to m³/h 18 (electric main pump 5" mono-block submersible type)

Code	Model	Electric Power (kW)	Q= CAPACITY OF EACH SERVICE PUMP										
			m³/h 0	2,1	4,2	6,3	7,2	9	12	14,4	18		
			l/m 0	35	70	105	120	150	200	240	300		
			H= Total head ( m.c.a. )										
700.577	2SP-P-K5-4/2-Q1,5	2x0.75+0.75	50	45	35*	21	14						
700.578	2SP-P-K5-4/3-Q1,5	2x1.1+1.1	67	61	48*	27	18						
700.579	2SP-P-K5-4/4-Q2	2x1.5+1.1	75	67	57*	40	32						
700.580	2SP-P-K5-4/5-Q3	2x2.2+1.5	105	96	80*	56	44						
700.581	2SP-S-M5-B/4-Q1,5	2x1.5+0.75	56	51	45	36*	32	19					
700.582	2SP-S-M5-B/5-Q2	2x1.5+1.1	69	62	55	44*	38	20					
700.583	2SP-S-M5-B/7-Q3	2x2.2+1.5	96	88	78	63*	55	30					
700.584	2SP-S-M5-C/3-Q2	2x1.5+0.75	38		37	34	33	31	25*	16	7		
700.585	2SP-S-M5-C/5-Q3	2x2.2+1.1	66		64	61	59	55	45*	32	15		
700.586	2SP-S-M5-C/6-Q3	2x3+1.1	77		75	72	70	65	52*	37	19		
700.587	2SP-S-M5-C/7-Q5,5	2x3.3+1.5	89		88	84	80	74	59*	42	20		
700.588	2SP-S-M5-C/9-Q7,5	2x4+2.2	113		110	107	103	92	80*	56	27		

### Components on requires

Product Code	Model	Description
700.589	SKID-SP-2	Assembly of the hydraulic control unit and the electrical control panels on a painted steel skid (pumps supplied separately)

Tolerances in table: ISO 9906 Annex A (performance at the outlet of the pump)  
\* maximum efficiency point

This type of pump is supplied with 15 meters of cable and does not require the cooling jacket. Pumps, electrical control panels and hydraulic control unit are supplied separately.

Fire fighting units with bore hole (submersible) pumps, made according to standard EN 12845

2 Electric main pump + 1 jockey pump (wall fixing)  
“2SP” Series

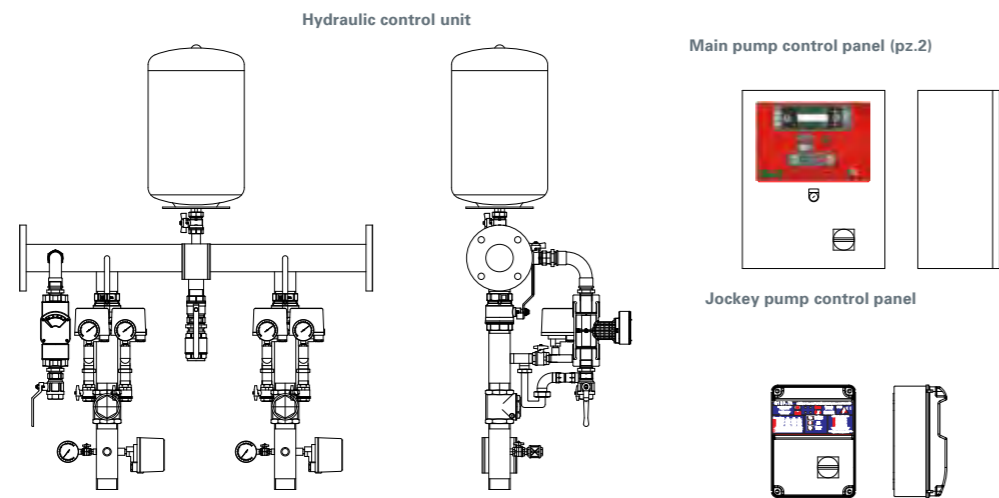

Units with capacity from m³/h 0 up to m³/h 25 (electric main pump 4” submersible type)

Code	Model	Electric Power (kW)	Q= CAPACITY OF EACH SERVICE PUMP														
			m³/h 0	5	6,3	7	8	9	10	11	12	14	16	18	20	22	25
			H= Total head ( m.c.a. )														
700.590	2SPm-S-NS95DA/8-O-Q2	2x1.5+0.75	52	46	43	41	38*	34	29	24							
700.591	2SPm-S-NS95DA/10-O-Q5,5	2x2.2+1.1	65	58	54	51	47*	42	36	30							
700.592	2SPm-S-NS95DA/13-O-Q5,5	2x2.2+1.1	85	75	70	67	61*	55	47	38							
700.593	2SPm-S-FS98E/7-O-Q2	2x1.1+0.75	49				35	31*	26	19	13						
700.594	2SPm-S-FS98E/9-O-Q2	2x1.5+0.75	62				45	40*	33	25	17						
700.595	2SPm-S-FS98E/11-O-Q5,5	2x2.2+1.1	76				55	49*	40	30	20						
700.596	2SPm-S-FS98E/13-O-Q5,5	2x2.2+1.5	88				65	58*	47	36	24						
700.597	2SPm-R-4ES12/17-44F-Q5,5	2x3+2.2	108		91	83	76	68*	62	56	44						
700.598	2SP4-R-4ES12/23-45F-Q7,5	2x4+1.5	148		125	118	110	100*	88	77	58						
700.599	2SPm-R-4ES24/8-43N-Q4	2x2.2+0.75	51			42	40	38	35	34	31	26*	21	18	14	12	
700.600	2SPm-R-4ES24/11-44F-Q5,5	2x3+1.1	70			58	56	54	50	48	44	39*	32	28	22	17	
700.601	2SPm-R-4ES24/13-45F-Q7,5	2x4+1.1	81			68	64	62	59	57	51	46*	39	34	28	21	
700.602	2SPm-R-4ES24/15-45F-Q7,5	2x4+2.2	97			80	76	74	71	68	61	56*	48	42	34	26	
700.603	2SP4-R-4ES24/20-47F-Q10	2x5.5+1.1	125			104	100	96	92	88	79	72*	62	54	46	36	

Components on requires

Product Code	Model	Description
700.589	SKID-SP-2	Assembly of the hydraulic control unit and the electrical control panels on a painted steel skid (pumps supplied separately)
700.515	CAM-4”	Cooling jacket in galvanized steel, which is necessary for correct cooling of the submersible 4” pump; to install a cooling jacket for each main pump (supplied separately) To install one more for the jockey pump only if the model of fire fighting unit starts with “SP4-”

Tolerances in table: ISO 9906 Annex A (performance at the outlet of the pump)  
\* maximum efficiency point

This type of fire fighting units mounted electric main pumps of the 4” submersible type, which are supplied with 1.5 meters of cable and require of the cooling jacket for a correct installation.

Fire fighting units with bore hole (submersible) pumps, made according to standard EN 12845

2 Electric main pump + 1 jockey pump (wall fixing)  
“2SP” Series

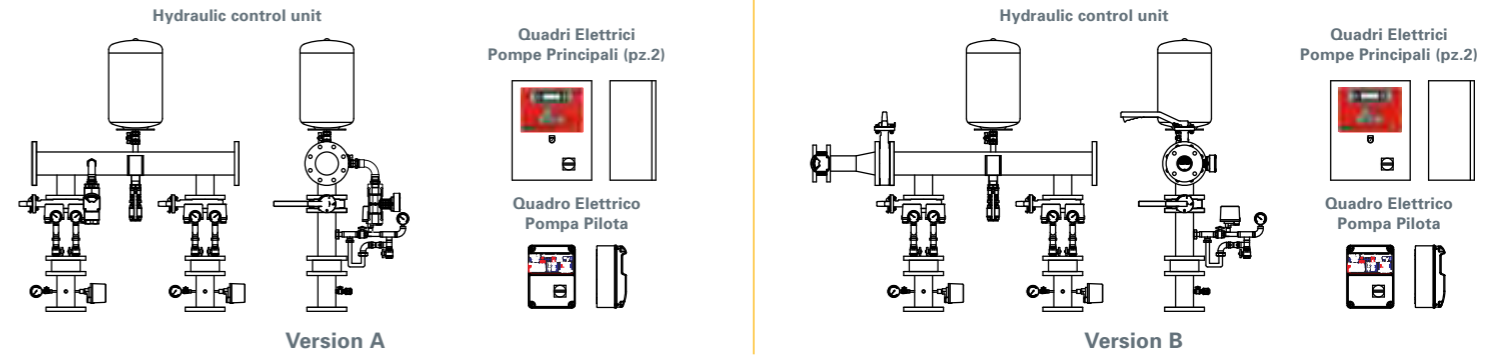

Units with capacity from m³/h 21.6 up to m³/h 90 (electric main pump 6” submersible type)

Code	Model	Electric Power (kW)	Q= CAPACITY OF EACH SERVICE PUMP														
			m³/h 0	21,6	27	28,8	30	36	43,2	48	50,4	56	60	72	84	90	
			H= Total head ( m.c.a. )														
700.607	2SPm-S-NR151F/4-O-Q7,5	2x3+0.75	46	34*	26	21	18,3										
700.608	2SPm-S-NR151F/6-O-Q10	2x4+1.1	69	50*	38	31	28,5										
700.609	2SPm-S-NR151F/8-O-Q10	2x5.5+1.5	92	67*	50	42	38										
700.610	2SP4-S-NR151F/11-O-Q12,5	2x7.5+1.1	127	90*	68	57	52										
700.611	2SPm-S-NR151E/3A-A-Q7,5	2x4+0.75	42	37	36	35	35*	30	22	16							
700.612	2SPm-S-NR151E/4-O-Q10	2x5.5+0.75	59	51	48	47	46*	40	29	22							
700.613	2SPm-S-NR151E/6B-O-Q12,5	2x7.5+1.1	81	73	71	68	67*	55	40	28							
700.614	2SPm-S-NR151E/7B-O-Q12,5	2x9.2+1.5	94	86	82	80	78*	65	58	33							
700.615	2SP4-S-NR151E/8-O-Q20	2x11+1.1	117	103	98	95	93*	79	59	41							
700.616	2SPm-S-NR152D/4-O-Q12,5	2x7.5+0.75	63				50	48	42*	25	20	12					
700.617	2SPm-S-NR152D/5-O-Q12,5	2x9.2+1.1	79				63	60	52*	42	32	25	15				
700.618	2SPm-S-NR152D/6-O-Q12,5	2x9.2+2.2	95				75	72	61*	48	38	28	18				
700.619	2SPm-S-NR152D/7-O-Q20	2x11+2.2	111				88	84	71*	52	44	34	21				
700.620	2SP4-S-NR152D/8-O-Q20	2x13+1.1	127				100	96	82*	61	50	39	24				
700.621	2SP4-S-NR152D/9-O-Q20	2x15+1.5	142				113	108	92*	70	57	44	27				
700.622	2SP4-S-S151A/8-O-Q20	2x15+1.5	137				108	106	98	88*	77	72	61	48			
700.623	2SPm-S-S151B/3-O-Q12,5	2x7.5+0.75	50					40	37	34	33	30*	29	20			
700.624	2SPm-S-S151B/4-O-Q12,5	2x9.2+1.1	66					42	49	44	43	40*	37	26			
700.625	2SPm-S-S151B/5-O-Q20	2x11+1.1	83					63	59	56	54	50*	46	33			
700.626	2SPm-S-S151B/6-O-Q20	2x13+2.2	99					77	72	68	68	60*	57	39			
700.627	2SP4-S-S151B/7-O-Q20	2x15+1.1	116					89	85	80	78	70*	67	46			
700.628	2SP4-S-S151B/8-A-Q30	2x18.5+1.5	132					102	97	90	88	80*	75	52			
700.629	2SPm-S-S151C/4-O-Q20	2x11+1.1	64									42	41	34*	25	20	
700.630	2SPm-S-S151C/5-O-Q20	2x13+1.1	80									53	52	43*	32	24	
700.631	2SPm-S-S151C/6A-OL-Q20	2x15+2.2	95									62	60	50*	36	27	
700.632	2SPm-R-6EC4/9-622-F-Q25	2x16.5+2.2	109									70	65	52*	39	22	
700.633	2SP4-R-6EC4/10-625-F-Q30	2x18.5+1.1	121									77	72	58*	43	36	
700.634	2SP4-R-6EC4/11-627-F-Q30	2x20+1.5	133									85	79	64*	49	41	
700.635	2SP4-R-6EC4/12-630-F-Q30	2x22+1.5	145									92	86	70*	53	45	
700.636	2SP4-S-S151C/9-A-Q40	2x26+1.5	144									95	92	77*	56	44	

Components on requires

Product Code	Model	Description
700.589	SKID-SP-2	Assembly of the hydraulic control unit and the electrical control panels on a painted steel skid (pumps supplied separately)
700.546	CAM-6”	Cooling jacket in galvanized steel, which is necessary for correct cooling of the submersible 6” main pump; to install a cooling jacket for each main pump (supplied separately)
700.515	CAM-4”	Cooling jacket in galvanized steel, which is necessary for correct cooling of the 4” jockey pump; to install only if the model of fire fighting unit begins with “SP4-”

Tolerances in table: ISO 9906 Annex A (performance at the outlet of the pump)  
\* maximum efficiency point

This type of fire fighting units mounted electric main pumps of the 6” submersible type, which are supplied with 1.5 meters of cable and require of the cooling jacket for a correct installation.



## Misure di ingombro – Gruppi Serie “2SP”

Fire fighting units with bore hole 5” mono-block pumps  
2 Electric main pumps + 1 jockey pump (wall fixing)

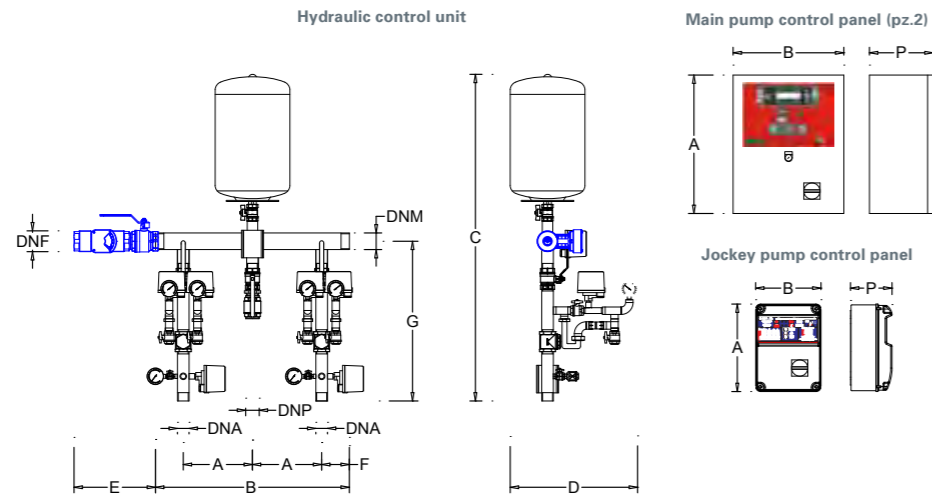

Units with capacity from m<sup>3</sup>/h 0 up to m<sup>3</sup>/h 18 (electric main pump 5” submersible type)

Fire Fighting Unit		Flow meter kit	Jockey Pump	Connections				Hydraulic control unit (mm)							main pump control panel (mm)			jockey pump control panel (mm)		
Code	Model			DNA	DNM	DNF	DNP	A	B	C	D	E	F	G	A	B	P	A	B	P
700.577	2SP-P-K5-4/2-Q1,5	KA-25-25	S1	1 1/4" M	2" M	1" F	1 1/4" F	250	700	1180*	460*	295*	100	580*	500	400	230	316	240	150
700.578	2SP-P-K5-4/3-Q1,5		S2																	
700.579	2SP-P-K5-4/4-Q2		S3																	
700.580	2SP-P-K5-4/5-Q3		S1																	
700.581	2SP-S-M5-B/4-Q1,5		S2																	
700.582	2SP-S-M5-B/5-Q2		S3																	
700.583	2SP-S-M5-B/7-Q3		S1																	
700.584	2SP-S-M5-C/3-Q2		S2																	
700.585	2SP-S-M5-C/5-Q3		S3																	
700.586	2SP-S-M5-C/6-Q3		S4																	
700.587	2SP-S-M5-C/7-Q5,5																			
700.588	2SP-S-M5-C/9-Q7,5																			

\* Tolerance of ± 50 mm  
 blue components: optional available on request

## Misure di ingombro – Gruppi Serie “2SP”

Fire fighting units with bore hole 5” mono-block pumps  
2 Electric main pumps + 1 jockey pump (on skid)

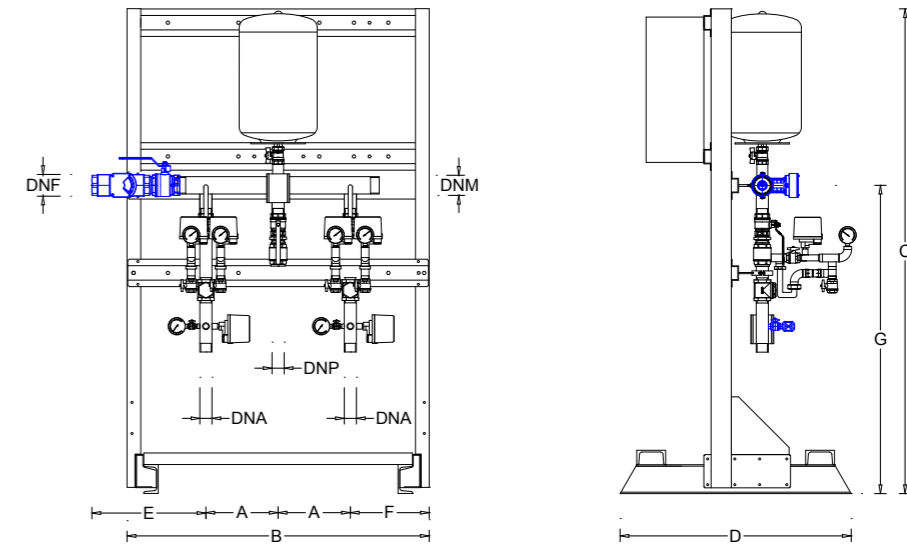

Units with capacity from m<sup>3</sup>/h 0 up to m<sup>3</sup>/h 18 (electric main pump 5” submersible type)

Fire Fighting Unit		Flow meter kit	Jockey Pump	Connections				Dimensions (mm)						
Code	Model			DNA	DNM	DNF	DNP	A	B	C	D	E	F	G
700.577+700.589	2SP-P-K5-4/2-Q1,5+SKID-SP-2	KA-25-25	S1	1 1/4" M	2" M	1" F	1 1/4" F	250	1046	1678	800	395	1067	273
700.578+700.589	2SP-P-K5-4/3-Q1,5+SKID-SP-2		S2											
700.579+700.589	2SP-P-K5-4/4-Q2+SKID-SP-2		S3											
700.580+700.589	2SP-P-K5-4/5-Q3+SKID-SP-2		S1											
700.581+700.589	2SP-S-M5-B/4-Q1,5+SKID-SP-2		S2											
700.582+700.589	2SP-S-M5-B/5-Q2+SKID-SP-2		S3											
700.583+700.589	2SP-S-M5-B/7-Q3+SKID-SP-2		S1											
700.584+700.589	2SP-S-M5-C/3-Q2+SKID-SP-2		S2											
700.585+700.589	2SP-S-M5-C/5-Q3+SKID-SP-2		S3											
700.586+700.589	2SP-S-M5-C/6-Q3+SKID-SP-2		S4											
700.587+700.589	2SP-S-M5-C/7-Q5,5+SKID-SP-2													
700.588+700.589	2SP-S-M5-C/9-Q7,5+SKID-SP-2													

\* Tolerance of ± 50 mm  
 blue components: optional available on request

## Misure di ingombro – Gruppi Serie “2SP”

Fire fighting units with bore hole 4” pumps  
2 Electric main pumps + 1 jockey pump (wall fixing)

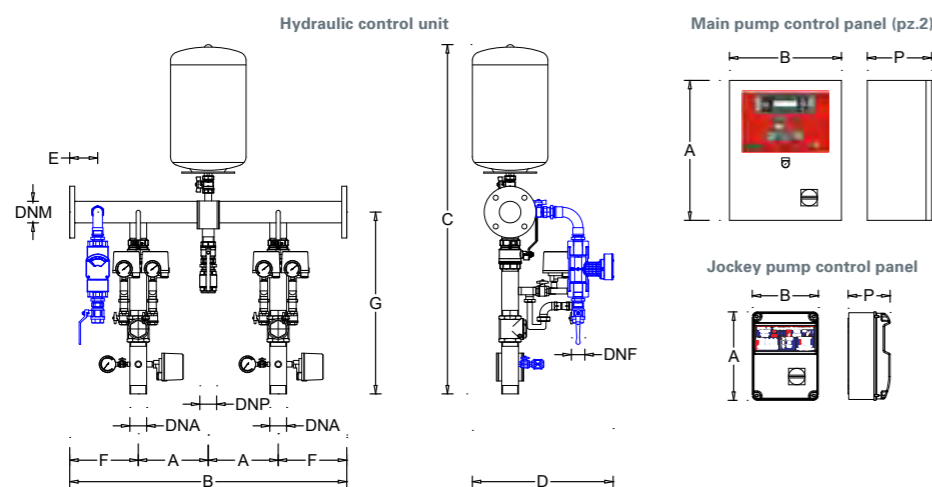

## Misure di ingombro – Gruppi Serie “2SP”

Fire fighting units with bore hole 4” pumps  
2 Electric main pumps + 1 jockey pump (on skid)

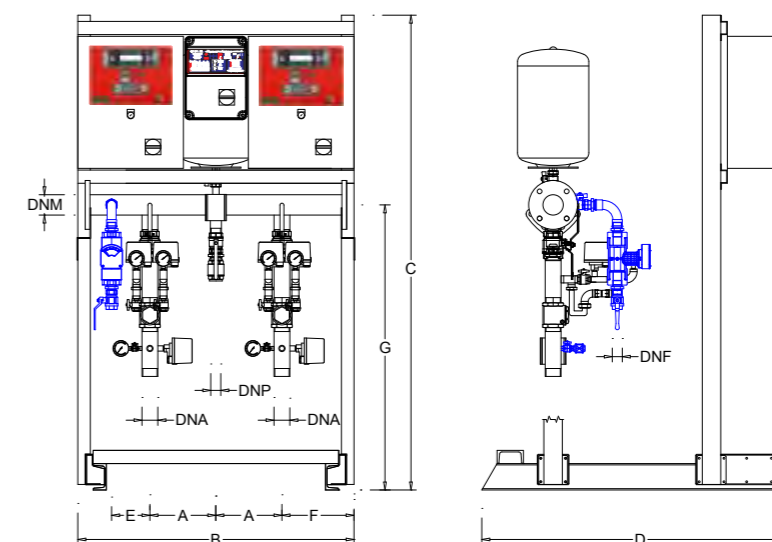

Units with capacity from m<sup>3</sup>/h 0 up to m<sup>3</sup>/h 25 (electric main pump 4” submersible type)

Fire Fighting Unit		Flow meter kit	Jockey Pump	Connections				Hydraulic control unit (mm)						main pump control panel (mm)			jockey pump control panel (mm)			
Code	Model			DNA	DNM	DNF	DNP	A	B	C	D	E	F	G	A	B	P	A	B	P
700.590	2SPm-S-NS95DA/8-O-Q2	KA-25-25	S1	2" M	DN65	1" F	1 1/4" F	250	990	1248*	505*	100	245	650*	500	400	230	316	240	150
700.591	2SPm-S-NS95DA/10-O-Q5,5		S2																	
700.592	2SPm-S-NS95DA/13-O-Q5,5		S1																	
700.593	2SPm-S-FS98E/7-O-Q2																			
700.594	2SPm-S-FS98E/9-O-Q2		S2																	
700.595	2SPm-S-FS98E/11-O-Q5,5		S3																	
700.596	2SPm-S-FS98E/13-O-Q5,5		S4																	
700.597	2SPm-R-4ES12/17-44F-Q5,5		S6																	
700.598	2SP4-R-4ES12/23-45F-Q7,5		S1																	
700.599	2SPm-R-4ES24/8-43N-Q4																			
700.600	2SPm-R-4ES24/11-44F-Q5,5		S2																	
700.601	2SPm-R-4ES24/13-45F-Q7,5		S4																	
700.602	2SPm-R-4ES24/15-45F-Q7,5																			
700.603	2SP4-R-4ES24/20-47F-Q10		S5																	

\* Tolerance of ± 50 mm  
blue components: optional available on request

Units with capacity from m<sup>3</sup>/h 0 up to m<sup>3</sup>/h 25 (electric main pump 4” submersible type)

Fire Fighting Unit		Flow meter kit	Jockey Pump	Connections				Dimensions (mm)						
Code	Model			DNA	DNM	DNF	DNP	A	B	C	D	E	F	G
700.590+700.589	2SPm-S-NS95DA/8-O-Q2+SKID-SP-2	KA-25-25	S1	2" M	DN65	1" F	1 1/4" F	250	1046	1678	1200	100	1080	273
700.591+700.589	2SPm-S-NS95DA/10-O-Q5,5+SKID-SP-2		S2											
700.592+700.589	2SPm-S-NS95DA/13-O-Q5,5+SKID-SP-2		S1											
700.593+700.589	2SPm-S-FS98E/7-O-Q2+SKID-SP-2													
700.594+700.589	2SPm-S-FS98E/9-O-Q2+SKID-SP-2		S2											
700.595+700.589	2SPm-S-FS98E/11-O-Q5,5+SKID-SP-2		S3											
700.596+700.589	2SPm-S-FS98E/13-O-Q5,5+SKID-SP-2		S4											
700.597+700.589	2SPm-R-4ES12/17-44F-Q5,5+SKID-SP-2		S6											
700.598+700.589	2SP4-R-4ES12/23-45F-Q7,5+SKID-SP-2		S1											
700.599+700.589	2SPm-R-4ES24/8-43N-Q4+SKID-SP-2													
700.600+700.589	2SPm-R-4ES24/11-44F-Q5,5+SKID-SP-2		S2											
700.601+700.589	2SPm-R-4ES24/13-45F-Q7,5+SKID-SP-2		S4											
700.602+700.589	2SPm-R-4ES24/15-45F-Q7,5+SKID-SP-2													
700.603+700.589	2SP4-R-4ES24/20-47F-Q10+SKID-SP-2		S5											

\* Tolerance of ± 50 mm  
blue components: optional available on request

## Misure di ingombro – Gruppi Serie “2SP”

Fire fighting units with bore hole 6” pumps  
2 Electric main pumps + 1 jockey pump (wall fixing)

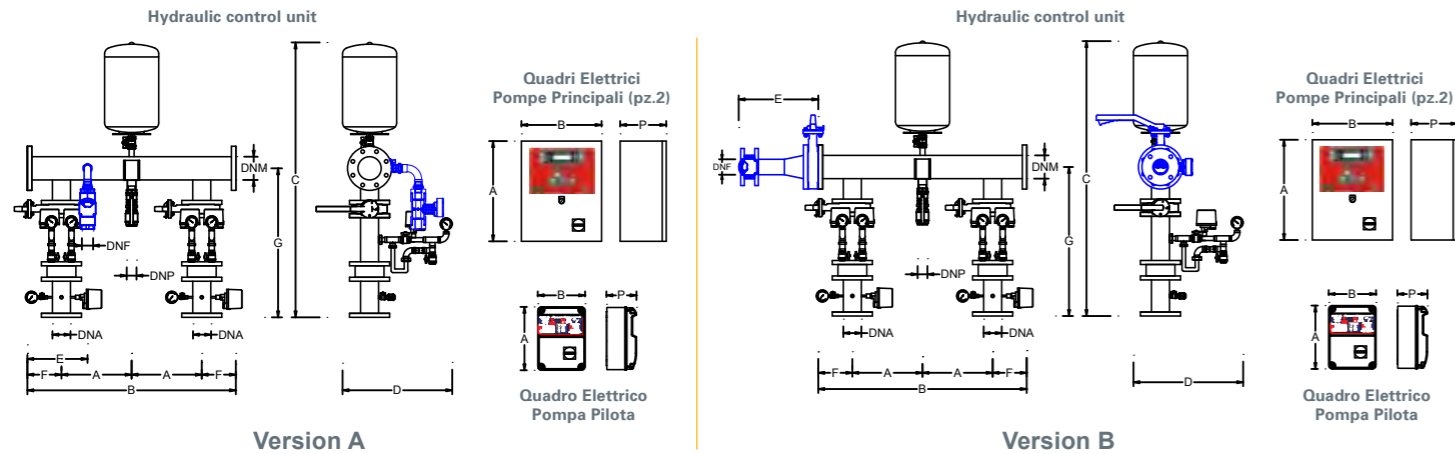

## Misure di ingombro – Gruppi Serie “2SP”

Fire fighting units with bore hole 6” pumps  
2 Electric main pumps + 1 jockey pump (on skid)

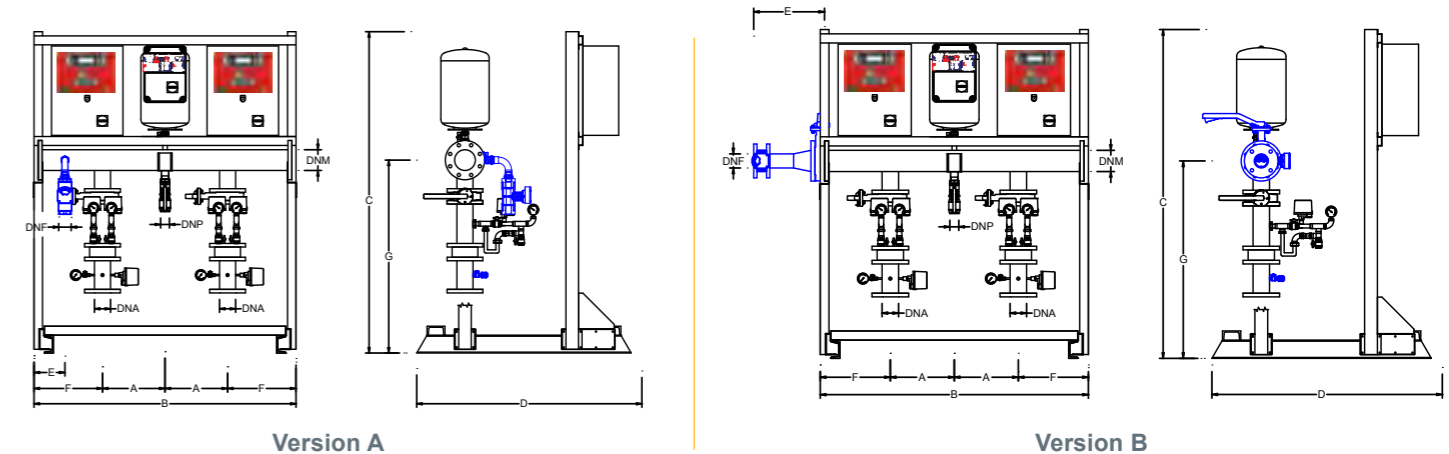

Units with capacity from m<sup>3</sup>/h 21.6 up to m<sup>3</sup>/h 90 (electric main pump 6” submersible type)

Fire Fighting Unit		Flow meter kit	Jockey Pump	Connections				Hydraulic control unit (mm)								main pump control panel (mm)			jockey pump control panel (mm)			
Code	Model			DNA	DNM	DNF	DNP	A	B	C	D	Version A		Version B		G	A	B	P	A	B	P
												E	F	E	F							
700.607	2SPm-S-NR151F/4-O-Q7,5	KA-40-40	S1	DN65	DN80	1 1/2" F									500	400						
700.608	2SPm-S-NR151F/6-O-Q10		S2																			
700.609	2SPm-S-NR151F/8-O-Q10		S3																			
700.610	2SP4-S-NR151F/11-O-Q12,5		S5																			
700.611	2SPm-S-NR151E/3A-A-Q7,5		S1																			
700.612	2SPm-S-NR151E/4-O-Q10		S2																			
700.613	2SPm-S-NR151E/6B-O-Q12,5		S3																			
700.614	2SPm-S-NR151E/7B-O-Q12,5		S5																			
700.615	2SP4-S-NR151E/8-O-Q20		S5																			
700.616	2SPm-S-NR152D/4-O-Q12,5		S1																			
700.617	2SPm-S-NR152D/5-O-Q12,5		S2																			
700.618	2SPm-S-NR152D/6-O-Q12,5		S4																			
700.619	2SPm-S-NR152D/7-O-Q20		S5																			
700.620	2SP4-S-NR152D/8-O-Q20		S6	KA-50-50	DN80																	DN100
700.621	2SP4-S-NR152D/9-O-Q20	S1																				
700.622	2SP4-S-S151A/8-O-Q20	S2																				
700.623	2SPm-S-S151B/3-O-Q12,5	S4																				
700.624	2SPm-S-S151B/4-O-Q12,5	S5																				
700.625	2SPm-S-S151B/5-O-Q20	S6																				
700.626	2SPm-S-S151B/6-O-Q20	S1																				
700.627	2SP4-S-S151B/7-O-Q20	S2																				
700.628	2SP4-S-S151B/8-A-Q30	S4																				
700.629	2SPm-S-S151C/4-O-Q20	S5																				
700.630	2SPm-S-S151C/5-O-Q20	S6																				
700.631	2SPm-S-S151C/6A-OL-Q20	S2																				
700.632	2SPm-R-6EC4/9-622-F-Q25	S4																				
700.633	2SP4-R-6EC4/10-625-F-Q30	S5	KB2-100-65					DN65														
700.634	2SP4-R-6EC4/11-627-F-Q30	S6																				
700.635	2SP4-R-6EC4/12-630-F-Q30	S1																				
700.636	2SP4-S-S151C/9-A-Q40	S2																				

\* Tolerance of ± 50 mm  
blue components: optional available on request

Pumps, electrical control panels and hydraulic control unit are supplied separately.

Units with capacity from m<sup>3</sup>/h 21.6 up to m<sup>3</sup>/h 90 (electric main pump 6” submersible type)

Fire Fighting Unit		Flow meter kit	Jockey Pump	Connections				Dimensions (mm)												
Code	Model			DNA	DNM	DNF	DNP	A	B	C	D	Version A		Version B		G				
												E	F	E	F					
700.607+700.589	2SPm-S-NR151F/4-O-Q7,5+SKID-SP-2	KA-40-40	S1	DN65	DN65															
700.608+700.589	2SPm-S-NR151F/6-O-Q10+SKID-SP-2		S2																	
700.609+700.589	2SPm-S-NR151F/8-O-Q10+SKID-SP-2		S3																	
700.610+700.589	2SP4-S-NR151F/11-O-Q12,5+SKID-SP-2		S5																	
700.611+700.589	2SPm-S-NR151E/3A-A-Q7,5+SKID-SP-2		S1																	
700.612+700.589	2SPm-S-NR151E/4-O-Q10+SKID-SP-2		S2																	
700.613+700.589	2SPm-S-NR151E/6B-O-Q12,5+SKID-SP-2		S3																	
700.614+700.589	2SPm-S-NR151E/7B-O-Q12,5+SKID-SP-2		S5																	
700.615+700.589	2SP4-S-NR151E/8-O-Q20+SKID-SP-2		S5																	
700.616+700.589	2SPm-S-NR152D/4-O-Q12,5+SKID-SP-2		S1																	
700.617+700.589	2SPm-S-NR152D/5-O-Q12,5+SKID-SP-2		S2																	
700.618+700.589	2SPm-S-NR152D/6-O-Q12,5+SKID-SP-2		S4																	
700.619+700.589	2SPm-S-NR152D/7-O-Q20+SKID-SP-2		S5																	
700.620+700.589	2SP4-S-NR152D/8-O-Q20+SKID-SP-2		S6	KA-50-50	DN80															
700.621+700.589	2SP4-S-NR152D/9-O-Q20+SKID-SP-2	S1																		
700.622+700.589	2SP4-S-S151A/8-O-Q20+SKID-SP-2	S2																		
700.623+700.589	2SPm-S-S151B/3-O-Q12,5+SKID-SP-2	S4																		
700.624+700.589	2SPm-S-S151B/4-O-Q12,5+SKID-SP-2	S5																		
700.625+700.589	2SPm-S-S151B/5-O-Q20+SKID-SP-2	S6																		
700.626+700.589	2SPm-S-S151B/6-O-Q20+SKID-SP-2	S1																		
700.627+700.589	2SP4-S-S151B/7-O-Q20+SKID-SP-2	S2																		
700.628+700.589	2SP4-S-S151B/8-A-Q30+SKID-SP-2	S4																		
700.629+700.589	2SPm-S-S151C/4-O-Q20+SKID-SP-2	S5																		
700.630+700.589	2SPm-S-S151C/5-O-Q20+SKID-SP-2	S6																		
700.631+700.589	2SPm-S-S151C/6A-OL-Q20+SKID-SP-2	S2																		
700.632+700.589	2SPm-R-6EC4/9-622-F-Q25+SKID-SP-2	S4																		
700.633+700.589	2SP4-R-6EC4/10-625-F-Q30+SKID-SP-2	S5	KB2-100-65					DN65												
700.634+700.589	2SP4-R-6EC4/11-627-F-Q30+SKID-SP-2	S6																		
700.635+700.589	2SP4-R-6EC4/12-630-F-Q30+SKID-SP-2	S1																		
700.636+700.589	2SP4-S-S151C/9-A-Q40+SKID-SP-2	S2																		

\* Tolerance of ± 50 mm  
blue components: optional available on request

The pumps are supplied separately

## Misure di ingombro – Gruppi Serie “2SP”

Fire fighting units with bore hole 8-10” pumps  
2 Electric main pumps + 1 jockey pump (wall fixing)

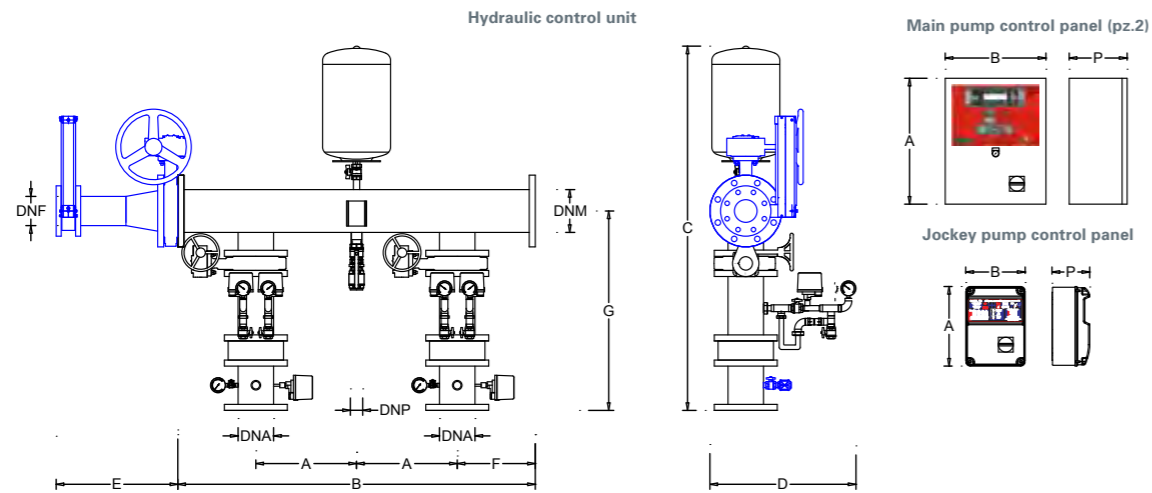

Units with capacity from m<sup>3</sup>/h 72 up to m<sup>3</sup>/h 280 (electric main pump 8” and 10” submersible type)

Fire Fighting Unit		Flow meter kit	Jockey Pump	Connections				Hydraulic control unit (mm)							main pump control panel (mm)			jockey pump control panel (mm)		
Code	Model			DNA	DNM	DNF	DNP	A	B	C	D	E	F	G	A	B	P	A	B	P
700.637	2SPm-R-8E2N/3F-615-F-Q20	KB2-150-80	S2	DN80	DN125	DN150	1447*	419	421	762	700	500	230	316	240	150				
700.638	2SPm-R-8E2N-3E-617-F-Q20																			
700.639	2SPm-R-8E2N/3B-620-F-Q25																			
700.640	2SPm-R-8E2N/4EF-622-F-Q25																			
700.641	2SPm-R-8E2N/4D-625-F-Q30																			
700.642	2SPm-R-8E2N/4B-627-F-Q30																			
700.643	2SP4-R-8E2N/5E-630-F-Q30																			
700.644	2SP4-R-8E2N/5A-635-F-Q40																			
700.645	2SP4-R-8E2N/6E-635-F-Q40																			
700.646	2SP4-R-8E2N/6B-640-F-Q50																			
700.647	2SPm-S-S181B/2A-O-Q20	KC-150-100	S1	DN100	1 1/4" F	400	1420	310	700	500	230	316	240	150						
700.648	2SPm-S-S181B/2-O-Q20																			
700.649	2SPm-S-S181B/3A-A-Q30																			
700.650	2SPm-S-S181B/3-A-Q30																			
700.651	2SP4-S-S181B/4-A-Q40																			
700.652	2SP4-S-S181B/5-A-Q50																			
700.653	2SPm-S-S181D/2-A-Q30																			
700.654	2SPm-S-S181D/3-A-Q40																			
700.655	2SP4-S-S181D/4-A-Q50																			
700.656	2SP4-S-S181D/5-A-Q75																			
700.657	2SPm-R-10E2N/2I-635-F-Q40	KC-200-125	S2	DN150	DN200	DN125	1512*	622	536	832	800	600	330	1000	800	1600				
700.658	2SPm-R-10E2N/2G-640-F-Q50																			
700.659	2SPm-R-10E2N/2D-850-N-Q60																			
700.660	2SP4-R-10E2N/3H-860-N-Q60																			
700.661	2SPm-S-S252A/2-A-Q75																			
700.662	2SP4-R-10E2N/3D-875-F-Q75																			
700.663	2SP4-S-S252A/3B-A-Q100																			
700.664	2SP4-S-S252A/3-A-Q150																			

\* Tolerance of ± 50 mm  
blue components: optional available on request

Pumps, electrical control panels and hydraulic control unit are supplied separately.

## Misure di ingombro – Gruppi Serie “2SP”

Fire fighting units with bore hole 8-10” pumps  
2 Electric main pumps + 1 jockey pump (on skid)

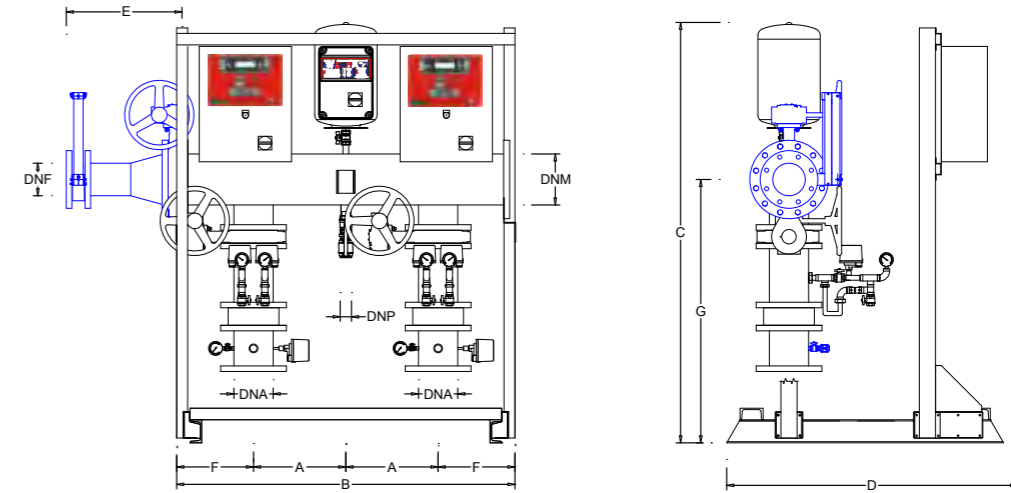

Units with capacity from m<sup>3</sup>/h 72 up to m<sup>3</sup>/h 280 (electric main pump 8” and 10” submersible type)

Fire Fighting Unit		Flow meter kit	Jockey Pump	Connections				Dimensions (mm)												
Code	Model			DNA	DNM	DNF	DNP	A	B	C	D	E	F	G						
700.637+700.589	2SPm-R-8E2N/3F-615-F-Q20+SKID-SP-2	KB2-150-80	S2	DN80	DN125	DN150	1775	1260	356	762	700	500	230	316	240	150				
700.638+700.589	2SPm-R-8E2N-3E-617-F-Q20+SKID-SP-2																			
700.639+700.589	2SPm-R-8E2N/3B-620-F-Q25+SKID-SP-2																			
700.640+700.589	2SPm-R-8E2N/4EF-622-F-Q25+SKID-SP-2																			
700.641+700.589	2SPm-R-8E2N/4D-625-F-Q30+SKID-SP-2																			
700.642+700.589	2SPm-R-8E2N/4B-627-F-Q30+SKID-SP-2																			
700.643+700.589	2SP4-R-8E2N/5E-630-F-Q30+SKID-SP-2																			
700.644+700.589	2SP4-R-8E2N/5A-635-F-Q40+SKID-SP-2																			
700.645+700.589	2SP4-R-8E2N/6E-635-F-Q40+SKID-SP-2																			
700.646+700.589	2SP4-R-8E2N/6B-640-F-Q50+SKID-SP-2																			
700.647+700.589	2SPm-S-S181B/2A-O-Q20+SKID-SP-2	KC-150-100	S1	DN100	1 1/4" F	400	1466	465	333	700	500	230	316	240	150					
700.648+700.589	2SPm-S-S181B/2-O-Q20+SKID-SP-2																			
700.649+700.589	2SPm-S-S181B/3A-A-Q30+SKID-SP-2																			
700.650+700.589	2SPm-S-S181B/3-A-Q30+SKID-SP-2																			
700.651+700.589	2SP4-S-S181B/4-A-Q40+SKID-SP-2																			
700.652+700.589	2SP4-S-S181B/5-A-Q50+SKID-SP-2																			
700.653+700.589	2SPm-S-S181D/2-A-Q30+SKID-SP-2																			
700.654+700.589	2SPm-S-S181D/3-A-Q40+SKID-SP-2																			
700.655+700.589	2SP4-S-S181D/4-A-Q50+SKID-SP-2																			
700.656+700.589	2SP4-S-S181D/5-A-Q75+SKID-SP-2																			
700.657+700.589	2SPm-R-10E2N/2I-635-F-Q40+SKID-SP-2	KC-200-125	S2	DN150	DN200	DN125	1822	1260	482	832	800	600	330	1000	800	1600				
700.658+700.589	2SPm-R-10E2N/2G-640-F-Q50+SKID-SP-2																			
700.659+700.589	2SPm-R-10E2N/2D-850-N-Q60+SKID-SP-2																			
700.660+700.589	2SP4-R-10E2N/3H-860-N-Q60+SKID-SP-2																			
700.661+700.589	2SPm-S-S252A/2-A-Q75+SKID-SP-2																			
700.662+700.589	2SP4-R-10E2N/3D-875-F-Q75+SKID-SP-2																			
700.663+700.589	2SP4-S-S252A/3B-A-Q100+SKID-SP-2																			
700.664+700.589	2SP4-S-S252A/3-A-Q150+SKID-SP-2																			

\* Tolerance of ± 50 mm  
blue components: optional available on request

# quadri elettrici forniti separati, dimensioni nella tabella precedente

The pumps are supplied separately



# 5.1

## Required components - supplied on Request

### Eccentrics reductions

Flanged reductions eccentric to be installed in the suction of main pumps, are complete of 1/4" out point, ball interception valve and vacuum gauge (or gauge on request). To choice it take the diameter inlet of the main pumps DNA (limit of standard) and then consult the following tables in order to define the enlargement of the eccentric cone DNB (depending on the type of installation: suction lift or positive head).

#### Choice of Eccentrics Reductions

The suction of the main pump must be connected to a pipe straight or conical, long at least two times of the pump's diameter suction. The reduction must be of the eccentric type, i.e. it should have the upper horizontal part and a bottom angle of maximum opening that is not more than 20°. The valves should not be placed directly on the suction pump. The inlet pipes need to be placed horizontally or with constant gradient up towards the pump to prevent the possibility of formation of air pockets.

Under the conditions of positive head, the diameter of the suction pipe must not be less than 65 mm (DN65). Moreover, the diameter should be such that the speed is not more than 1.8 m/s, when the pump is running at the maximum required flow rate.

Under the conditions of suction lift, the diameter of the suction pipe must not be less than 80 mm (DN80). Moreover,

the diameter should be such that the speed is not greater than 1.5 m/s, when the pump is running at maximum flow rate required.

Nelle condizioni di soprabattente, il diametro della tubazione di aspirazione non deve essere minore di 80 mm. Inoltre il diametro deve essere tale che la velocità non sia maggiore di 1,5 m/s quando la pompa sta funzionando alla portata massima richiesta.

**Please note that the following tables reflect only the details concerning the maximum permissible speed on suction pumps, the sizing may not be enough, as the EN 12845 standard requires that the suction pipe, including all valves and fittings must be designed to ensure that the available NPSH (calculated at the maximum expected temperature of the water) at the pump inlet exceeds the NPSH required at least 1 m at maximum capacity of the pump as shown in Table 14 of EN 12845.**

In the table on the side, are also indicated the reduction eccentric dimensions(L) and lowering suction interaxis (dh) than the values given in fire fighting unit's dimensions tables.

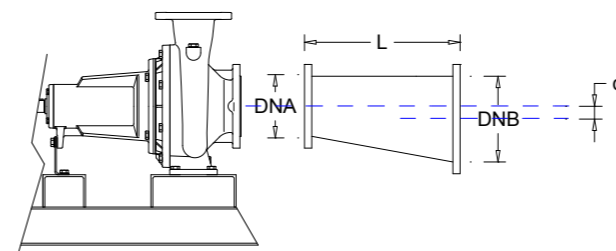

dh: value to be subtracted from main pumps interaxis suction, shown in dimensions tables of fire fighting units with "back pull-out" main pumps

Code	Reduction model	DNA	DNB	L (mm)	dh (mm)
700.665	RE50-65	DN50	DN65	200	8
700.666	RE50-80	DN50	DN80	180	15
700.667	RE50-100	DN50	DN100	200	28
700.668	RE50-125	DN50	DN125	235	40
700.669	RE65-80	DN65	DN80	210	6.5
700.670	RE65-100	DN65	DN100	250	20
700.671	RE65-125	DN65	DN125	210	32
700.672	RE65-150	DN65	DN150	270	46
700.673	RE65-200	DN65	DN200	415	70
700.674	RE80-100	DN80	DN100	210	12
700.675	RE80-125	DN80	DN125	200	25
700.676	RE80-150	DN80	DN150	325	40
700.677	RE80-200	DN80	DN200	410	65
700.678	RE80-250	DN80	DN250	550	91
700.679	RE100-150	DN100	DN150	225	27
700.680	RE100-200	DN100	DN200	325	52
700.681	RE100-250	DN100	DN250	455	80
700.682	RE125-200	DN125	DN200	385	40
700.683	RE125-250	DN125	DN250	415	68
700.684	RE125-300	DN125	DN300	545	92
700.685	RE150-250	DN150	DN250	365	51
700.686	RE150-300	DN150	DN300	520	78
700.687	RE150-350	DN150	DN350	560	92
700.688	RE150-400	DN150	DN400	710	120
700.689	RE200-300	DN200	DN300	435	52
700.690	RE200-350	DN200	DN350	435	69
700.691	RE200-400	DN200	DN400	555	95

### Positive head installation

#### Selection table of the reduction eccentric (V ≤ 1.8 m / s)

In order to maintain inside the suction pipe of the main pump flow rates indicated in standard EN 12845, depending on the maximum flow rate required by the fire-fighting network, it should expand suction pipe from the main inlet pump to the minimum diameter indicated in the following table:

Q (l/m)	0÷358	359÷542	543÷848	849÷1324	1325÷1907	1908÷3390	3391÷5297	5298÷7626	7627÷10381	10382÷13558
D min	DN65	DN80	DN100	DN125	DN150	DN200	DN250	DN300	DN350	DN400

### Suction lift installation

#### Selection table of the reduction eccentric (V ≤ 1.5 m / s)

In order to maintain inside the suction pipe of the main pump flow rates indicated in standard EN 12845, depending on the maximum flow rate required by the fire-fighting network, it should expand suction pipe from the main inlet pump to the minimum diameter indicated in the following table:

Q (l/m)	0÷452	453÷706	707÷1103	1104÷1589	1590÷2824	2825÷4413	4414÷6355	6356÷8650	8651÷11299
D min	DN80	DN100	DN125	DN150	DN200	DN250	DN300	DN350	DN400

# 5.2

## Interception butterfly valves – LUG type

Interception butterfly valve LUG type, with threaded ears, complete with operating lever up to DN100 and hand-wheel for larger diameters. The limit switch for monitoring the ON/OFF valve are available on request.

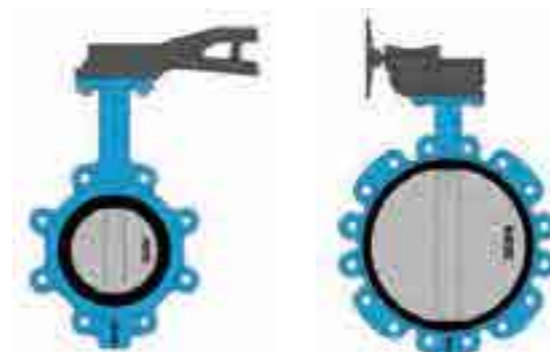

Code	Valve type	DN
700.692	LUG-50	DN50
700.693	LUG-65	DN65
700.694	LUG-80	DN80
700.695	LUG-100	DN100
700.696	LUG-125	DN125
700.697	LUG-150	DN150
700.698	LUG-200	DN200
700.699	LUG-250	DN250
700.700	LUG-300	DN300
700.701	LUG-350	DN350
700.702	LUG-400	DN400

#### Choice of limit switches

Code	Contact mode	for valve size
700.703	FC50-80	DN50-DN80
700.704	FC100	DN100
700.705	FC-RM	> DN100

## 5.3

### Rubber wedge gate valves with position indicator

Interception gate valves PN16 with rubber wedge position indicator and hand-wheel, according to Standard EN1171, EN1074-1, EN1074-2.



Code	Valve model	DN
700.706	SCPI-50	DN50
700.707	SCPI-65	DN65
700.708	SCPI-80	DN80
700.709	SCPI-100	DN100
700.710	SCPI-125	DN125
700.711	SCPI-150	DN150
700.712	SCPI-200	DN200
700.713	SCPI-250	DN250
700.714	SCPI-300	DN300
700.715	SCPI-350	DN350
700.716	SCPI-400	DN400

Choice of limit switches  
(valid for each valve size)

Code	Contact mode
700.717	FC- SCPI

## 5.6

### Bottom valves complete with strainer

Always are necessary if the installation of fire fighting unit is "suction lift", or are also required when the installation is "positive head" but the axis of the main pump is located above the minimum water level "X" (see item 9.3.5 - EN 12845).



Code	Model	DN
700.735	VF-50	2"
700.736	VF-65	DN65
700.737	VF-80	DN80
700.738	VF-100	DN100
700.739	VF-125	DN125
700.740	VF-150	DN150
700.741	VF-200	DN200
700.742	VF-250	DN250
700.743	VF-300	DN300
700.744	VF-350	DN350
700.745	VF-400	DN400

## 5.4

### Threaded brass gate valves

Interception gate valve in heavy brass, threaded



Code	Valve model	Ø
700.718	SOF-25	1" F
700.719	SOF-32	1 1/2" F
700.720	SOF-40	1 1/2" F
700.721	SOF-50	2" F
700.722	SOF-65	2 1/2" F
700.723	SOF-80	3" F

## 5.5

### Elastic vibration compensators

In presence of diesel motorpump is recommended to install on suction an elastic anti-vibration compensator to dampen the vibrations (in the delivery of the pump is already present). By inserting a compensator between two manifolds you can connect each two fire fighting modules.



Code	Model	DN	L (mm)	Compression	Extension	Lateral movement	Angle of inclination
700.604	CE-F-25	threaded 1" F	203	22	6	22	25°
700.605	CE-F-32	threaded 1 1/2" F	203	22	6	22	25°
700.606	CE-F-40	threaded 1 1/2" F	203	22	6	22	20°
700.724	CE-50	DN50 PN16	105	10	7	10	15°
700.725	CE-65	DN65 PN16	115	13	7	12	15°
700.726	CE-80	DN80 PN16	130	15	8	12	15°
700.727	CE-100	DN100 PN16	135	19	10	13	15°
700.728	CE-125	DN125 PN16	170	19	12	13	15°
700.729	CE-150	DN150 PN16	180	20	12	14	15°
700.730	CE-200	DN200 PN16	205	25	16	22	15°
700.731	CE-250	DN250 PN16	245	25	16	22	15°
700.732	CE-300	DN300 PN16	260	25	16	22	15°
700.733	CE-350	DN350 PN16	265	25	16	22	15°
700.734	CE-400	DN400 PN16	265	25	16	22	15°

### PRESSURE DROPS TABLE (foot valves up to DN300)

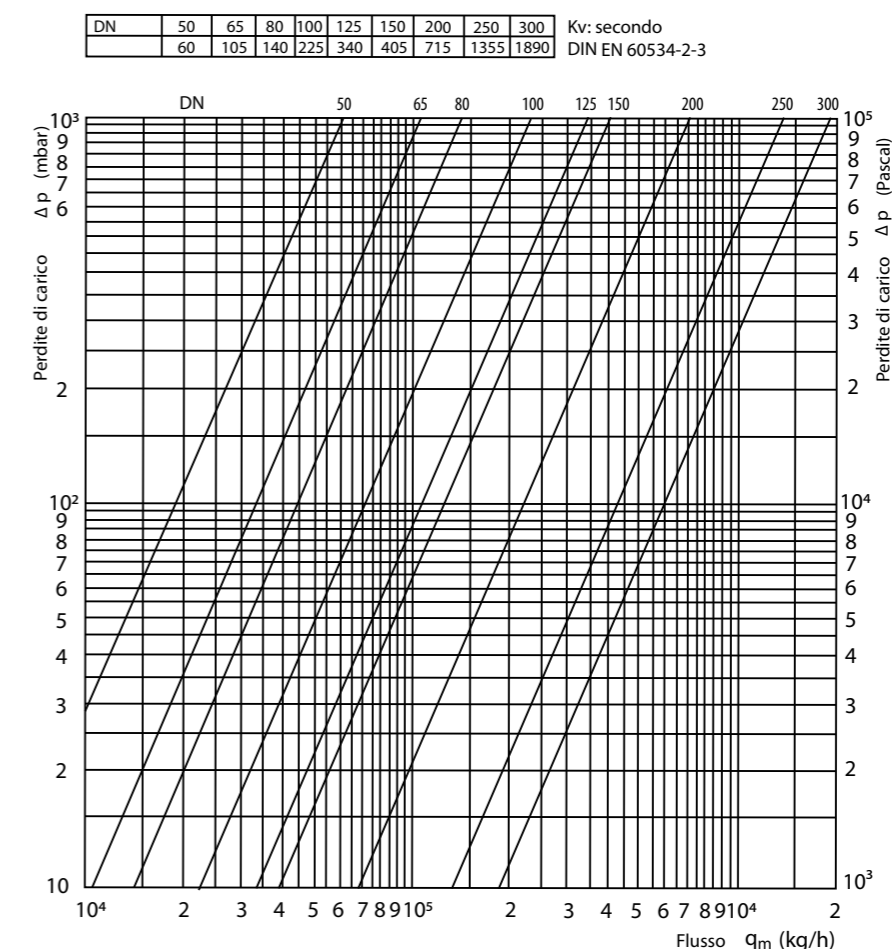

## 5.7

### Priming tanks with EN 12845 standard

(required only for suction lift installation - one tank for each main pump)

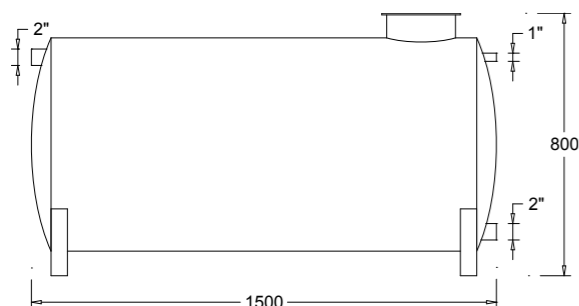

Priming tank 500 liter, galvanized steel complete with:  
 - A level switch for low level signal  
 - Float valve for supplying the tank (1")  
 - Output for pump priming (2"), recirculation input, interception valves and discharge, accessories

Code	Model	Connection
600.126	VAD-500	Load: 1" Overflow: 2" Priming: 2"

## 5.8

### Kit flowmeter

Kit of connection between the fire fighting delivery manifold and the flow meter, composed by: interception valve, steel galvanized socket with adequate length and flowmeter. In the case of flanged composition is also supplied with the counter-flange to be inserted after the flowmeter, with two

black rubber gaskets and bolts for fixing the flowmeter. Please note that is necessary the insertion after the flowmeter of another interception valve for adjusting the water flow.

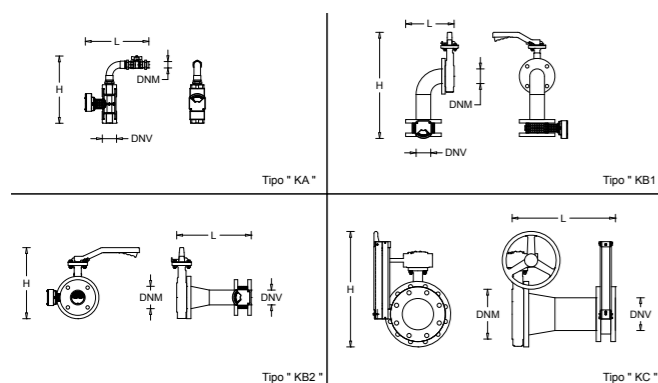

Flow meter kit		Full scale m³/h	Type	Connections		Dimensions (mm) L	Dimensions (mm) H
Code	Model			DNM	DNV		
700.746	KA-25-25	25	"KA"	1" gas M	1" gas F	350	340
700.747	KA-32-32	40	"KA"	1 1/4" gas M	1 1/4" gas F	373	350
700.748	KA-40-40	55	"KA"	1 1/2" gas M	1 1/2" gas F	373	350
700.749	KA-50-50	85	"KA"	2" gas M	2" gas F	373	370
700.750	KB1-65-65	145	"KB1"	DN65	DN65	252	550
700.751	KB2-100-65	145	"KB2"	DN100	DN65	397	370
700.752	KB2-100-80	200	"KB2"	DN100	DN80	402	370
700.833	KB2-125-80	200	"KB2"	DN125	DN80	426	420
700.834	KB2-150-80	200	"KB2"	DN150	DN80	430	547
700.753	KC-125-100	250	"KC"	DN125	DN100	420	420
700.835	KC-150-100	250	"KC"	DN150	DN100	490	547
700.754	KC-150-125	420	"KC"	DN150	DN125	472	547
700.836	KC-200-125	420	"KC"	DN200	DN125	536	600
700.755	KC-200-150	580	"KC"	DN200	DN150	536	600
700.837	KC-200-200	1000	"KC"	DN200	DN200	438	600
700.756	KC-250-200	1000	"KC"	DN250	DN200	636	670

## 5.9

### Direct reading flowmeters (only measuring instrument)

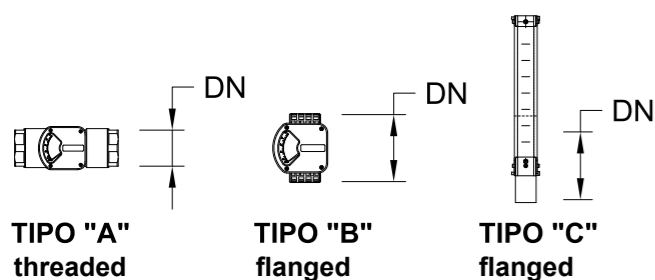

Code	Model	Full scale	Type	DN
700.757	M-25	m³/h 25	"A"	1" gas F
700.758	M-32	m³/h 40	"A"	1 1/4" gas F
700.759	M-40	m³/h 55	"A"	1 1/2" gas F
700.760	M-50	m³/h 85	"A"	2" gas F
700.761	M-65	m³/h 145	"B"	DN65 (wafer)
700.762	M-80	m³/h 200	"B"	DN80 (wafer)
700.763	M-100	m³/h 250	"C"	DN100 (wafer)
700.764	M-125	m³/h 420	"C"	DN125 (wafer)
700.765	M-150	m³/h 580	"C"	DN150 (wafer)
700.766	M-200	m³/h 1000	"C"	DN200 (wafer)

## 5.10

### Pump compartment kit sprinkler protection

On the delivery of each main pump there is a derivation for sprinkler pump's room protection. The kit will be supplied with interception valve (1 1/2"), flow alarm (to provide remote visual indication and sound operation of sprinklers) and test valve discharging system (1/2 "). In the case of two main pumps is possible provide a manifold connection between the two pumps that allows the immediate integration and

use of "kits sprinkler protection technical compartment." Ordering the kit sprinkler "KIT-SPK" are included 2 sprinklers supplied separately, K 80 pendent with glass bulb breaking temperature 141° C (in case you also ordered the manifold connection 'RAC-2 "will be supplied an additional sprinkler of the same characteristics).

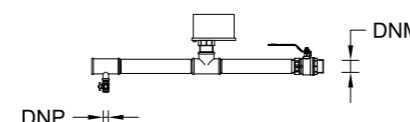

Code	Model	Description
700.767	KIT-SPK	Kit according to drawing (DNM 1 1/2" - DNP 1/2")
700.768	RAC-2	Manifold connection for two main pumps

## 5.11

### Self-powered remote acoustic/luminous alarms

These equipments permit monitoring and remote signaling of fire alarms related to the fire fighting booster set, in according to the EN12845 standard.



Code	Model	alarm input "type A"	alarm input "type B"
600.144	AC/LU13	nr. 1	nr. 3
600.145	AC/LU412	nr. 4	nr. 12

#### mod. AC/LU13 (no. 1 alarm input "Level A" and no. 3 alarm inputs "level B")

Features: Electronic control panel for alarm signalling; Input voltage 1 ~ 50/60Hz 230V ±10%; Transformer 230 V/24 V for auxiliary circuit; Nr.1 very low voltage input from free NC contact for alarm fire "level A" (at the opening of the NC contact the red flashing light and the buzzer activate); Nr.3 very low voltage input from free NC contact for alarm breakdown "level B" (when opening the NC contact the yellow flashing light and the buzzer activate); Nr.1 very low voltage input from free NO contact for alarm breakdown "Level B" (when closing the NO contact the yellow flashing light and the buzzer activate); Green light for power on; Red light for "alarm"; Red light for "beacon excluded"; Pushbutton "test" for temporary activation of the beacon; Pushbutton "reset" for manual restoration of the alarm; Pushbutton "beacon activation" for the activation of the acoustic alarm; Pushbutton "beacon exclusion" for the exclusion of the acoustic alarm; Internal selector for selecting the alarm restoration mode (automatic-manual); Internal selector for activation of the timer for automatic switch-off

of the beacon; Trimmer for automatic switch-off time delay selection (from 25" to 120"); Alarm beacon 90dB 12Vcc; Sealed internal battery for back-up 12Vcc 1,2Ah; Auxiliary protection fuse; Battery protection fuse; General alarm output with exchangeable contact (max 5A 250V AC1); Red flashing light 12Vcc; Yellow flashing light 12Vcc; Box in thermoplastic material; Output with cable holder; Protection IP55; Ambient temperature: -5/+40 °C

#### mod. AC/LU412 (no. 4 alarm input "Level A" and no. 12 alarm inputs "level B")

Electronic control panel alarm with features as described above, but with nr.4 very low voltage inputs from NC dry contact for fire alarm "level A" (the opening of NC contact activates the flashing red and the buzzer) and nr. 12 very low voltage inputs from NC dry contact for fault alarm "level B" (the opening of NC contact activates the yellow flashing light and buzzer).

## 5.12

### Flow recirculation visual indicators

Each main pump is equipped with a device to ensure a continuous flow of water through the pump, sufficient to prevent overheating when it works with the delivery closed. The discharge circuit should be clearly visible and where there is more of one pump, circuit discharges must be separated.



Code	Model	diameter	Pmax
700.769	IN-FL1/4	¼" gas F	25 bar
700.770	IN-FL1/2	½" gas F	15 bar
700.771	IN-FL1	1" gas F	12 bar
700.839	IN-FL S32 **	DN 32	16 bar
700.840	IN-FL S40 **	DN 40	16 bar
700.841	IN-FL S50 **	DN 50	16 bar

## 5.13

### Diesel engine spare parts kit (UNI EN 12845 - point 9.10.12)

The EN 12845 standard requires that the motorpump be supplied with the following spare parts of diesel engine:

- two sets of filter elements and related fittings for fuel
- two series of filter elements and related fittings for the lubricating oil
- two series of belts (if present)
- a complete set of fittings, seals and flexible motor
- Two injector nozzles

The kit follows the standards of the engine manufacturer.

Code	Spare parts model	Diesel engine model	Cooling
700.787	R-15LD350	...-5.8	air
700.788	R-15LD440	...-8.4	air
700.789	R-25LD425/2	...-14.4	air
700.790	R-12LD477/2	...-18.5	air
700.791	R-9LD625/2	...-24	air
700.792	R-LPW3	...-27	water with radiator
700.793	R-11LD626/3	...-36	air
700.794	R-D703EO.FRP	...-42.5	water with radiator
700.795	R-LPWT4	...-50	water with radiator
700.796	R-D703TEO.FRP	...-65.3	water with radiator
700.797	R-D754TPE2.FRP	...-89.8	water with radiator
700.798	R-N45MNSF40.10	...-133.4	water with radiator
700.799	R-N45MNTF41.10	...-177.5	water with radiator
700.800	R-N45MNTF40.10	...-200.7	water with radiator
700.801	R-N67MNTF42.10	...-242	water with radiator
700.802	R-N67MNTF41.10	...-272	water with radiator
700.803	R-N67MNTF40.10	...-302	water with radiator

## 5.14

### Membrane pressure tanks

Interchangeable membrane tanks of cylindrical vertical PN16, CE approved (97/23/EC), for pressurization systems and suitable for drinking water. The supply includes a shut-off valve of adequate diameter supplied separately.

Code	Membrane tank model	CAPACITY (lt)	Ø (mm)	H (mm)	Threaded connection
700.814	AFV 24 PN16+VS25	24	270	470	1" M
700.815	AFV 100 PN16+VS25	100	500	805	1" M
700.816	AFV 200 PN16+VS32	200	600	1065	1 ½" M
700.817	AFV 300 PN16+VS32	300	650	1270	1 ½" M
700.818	AF 500 PN16+VS32	500	650	1870	1 ½" M

## 5.15

### Heat exchangers water/water for diesel engines

All fire fighting units with diesel motorpump equipped with water-cooled diesel engine, have as standard a cooling radiator; on request is possible to supply the diesel engine water cooled by a heat exchanger water/water. The system takes the water required for engine cooling directly from the main pump, this capacity is not considered valid in the calculation of fire flow (to choose properly the fire pump is necessary to sum to the flow rate required in the project the

flow required by the exchanger).

The layout of the cooling system with heat exchanger water/water, includes a by-pass circuit complete with valves, pressure reducing, pressure gauge and "Y" filters (see picture).

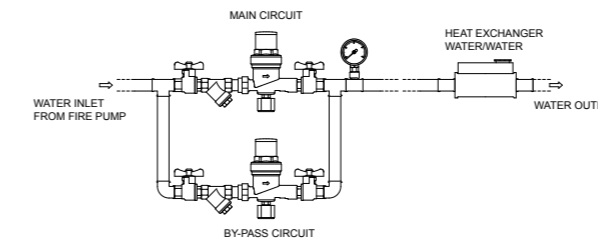

Code	Exchanger model	Diesel engine model	Exchanger's capacity (l/m)	Inlet pressure (bar)
----	Not available	...-5.8	----	----
----	Not available	...-8.4	----	----
----	Not available	...-14.4	----	----
----	Not available	...-18.5	----	----
----	Not available	...-24	----	----
700.804	SC-LPW3	...-27	50	1,5+2
----	Not available	...-36	----	----
700.805	SC-D703EO.FRP	...-42.5	90	1,5+2
700.806	SC-LPWT4	...-50	90	1,5+2
700.807	SC-D703TEO.FRP	...-65.3	90	1,5+2
700.808	SC-D754TPE2.FRP	...-89.8	90	1,5+2
700.809	SC-N45MNSF40.10	...-133.4	105	1,5+2
700.810	SC-N45MNTF41.10	...-177.5	105	1,5+2
----	Not available	...-200.7	----	----
700.811	SC-N67MNTF42.10	...-242	150	1,5+2
700.812	SC-N67MNTF41.10	...-272	150	1,5+2
700.813	SC-N67MNTF40.10	...-302	150	1,5+2

# 6.1

## Hydraulic diagram of fire fighting unit

Hydraulic diagram of fire fighting unit complete with 2 main pumps + 1 jockey pump (for suction lift installation)

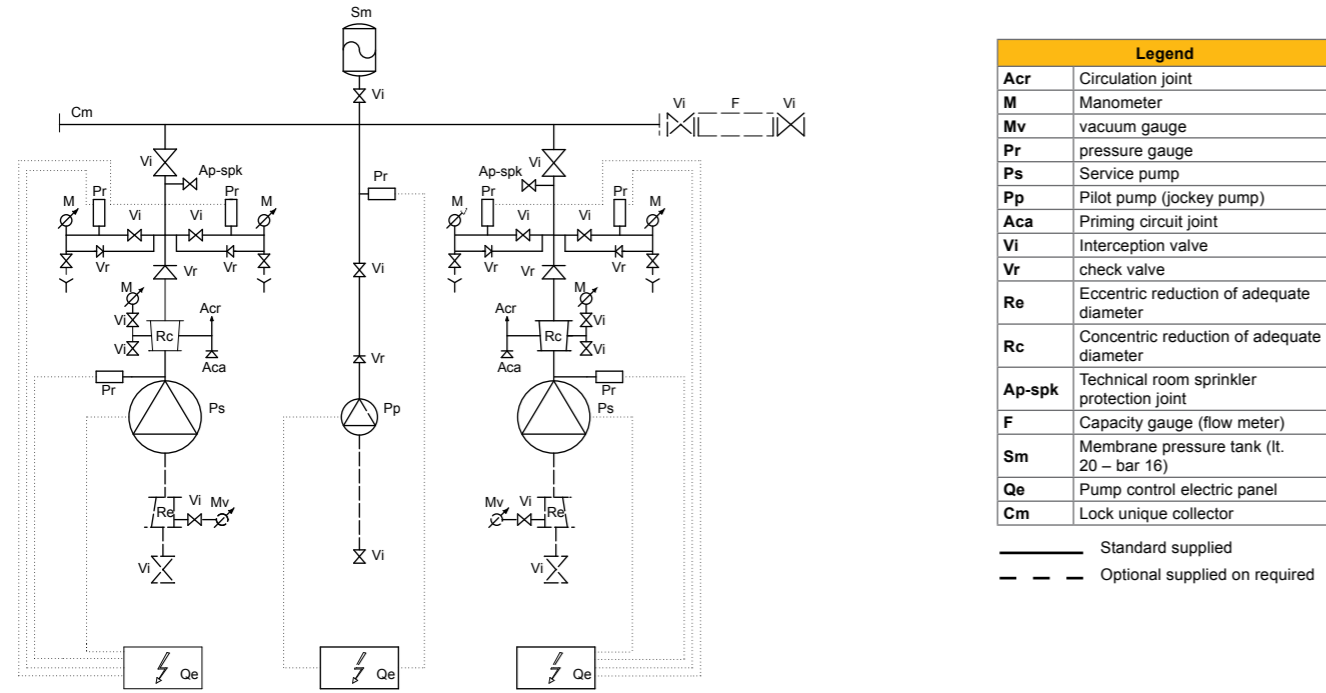

# 6.2

## hydraulic diagram of fire fighting unit with suction lift installation

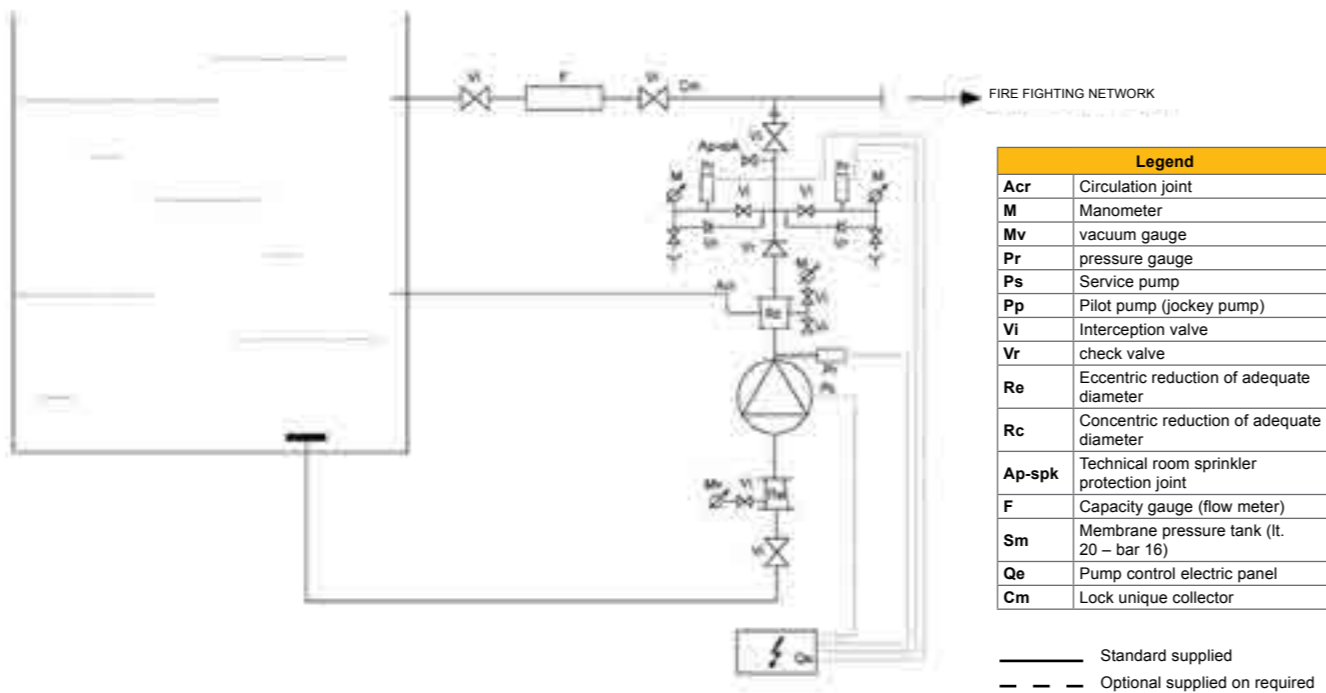

# 6.3

## hydraulic diagram of fire fighting unit with positive head installation

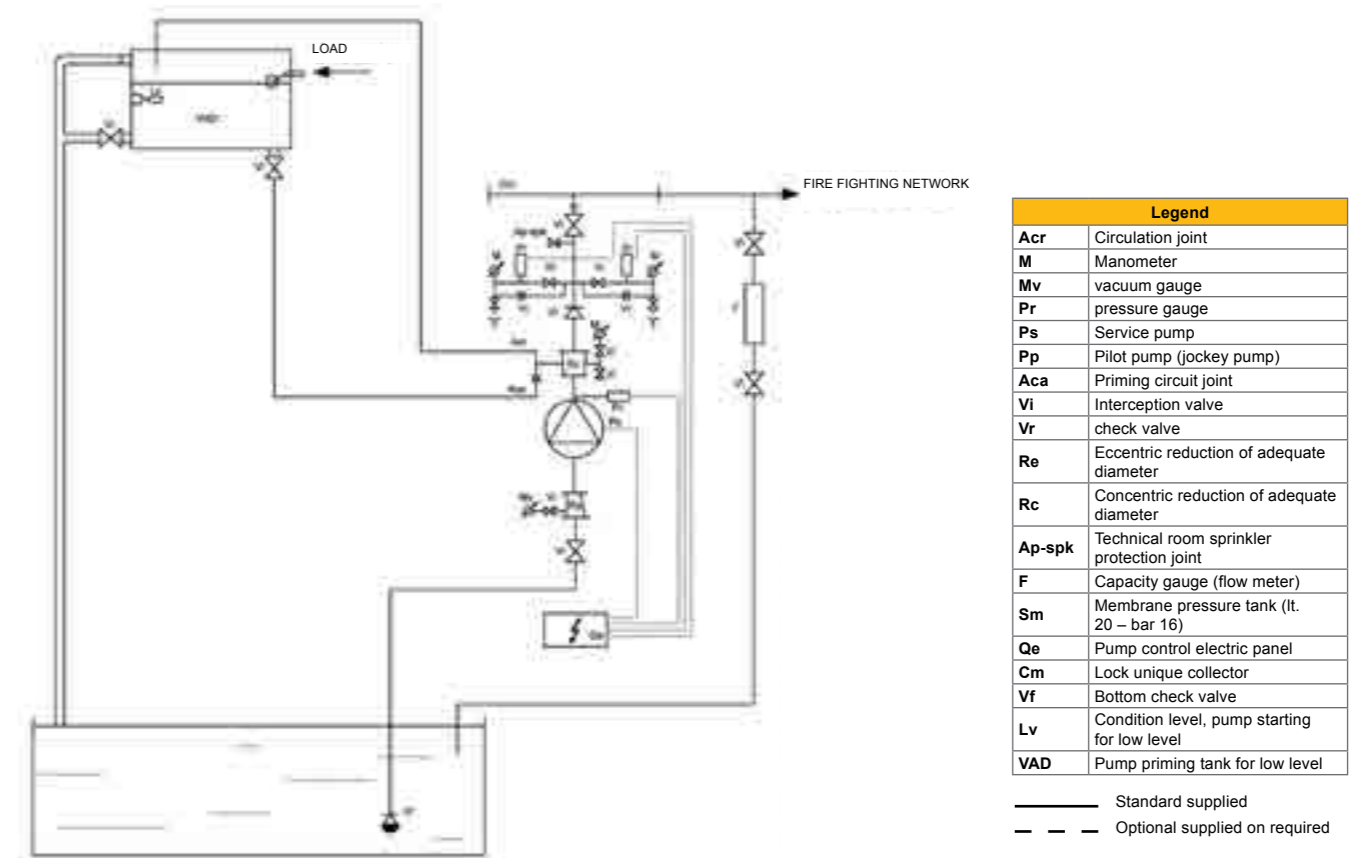

# Pictures of some of our realizations











# Sales general conditions

All sales entered into by Fourgroup S.r.l. (the Vendor) are to be governed exclusively by the following Sales General Conditions.

Any clause or condition drawn up by the Buyer shall become null and void if found to be in conflict with the following conditions.

## 1. Quotes, orders and order confirmation

- 1.1. Estimates issued by Fourgroup S.r.l., including the description, technical features and prices of the goods shall not in any case be considered as a binding sales agreement, but rather a quote. The conditions set forth in said quote shall lose all validity and effect thirty days from the time they are transmitted to the Customer, unless Fourgroup S.r.l. receives an Order from the Customer in the meantime.
- 1.2. The Buyer's Order must include indication of the quantity and name of the products required. Unwritten orders (required by phone or verbally) have to be confirmed with a written reply by the buyer; otherwise Fourgroup doesn't take charge of any kind of mistakes about orders proceeding.
- 1.3. The mere sending of the Order by the Buyer shall imply that the Buyer has read and is familiar with all these General Conditions of Sale, which shall consequently be fully accepted unconditionally and without restriction by the Parties.
- 1.4. Buyer's Orders only become binding for the Fourgroup S.r.l. after the latter has sent an Order Confirmation to the Buyer. The Buyer will totally accept these General Condition of Sales, products quantity and prices, once two days have elapsed from the receiving of order confirmation even if the buyer doesn't send the same order confirmation stamped and countersigned to Fourgroup S.r.l.
- 1.5. Information provided in catalogues, schedules and price-lists is not binding for Fourgroup S.r.l., which reserves the right to make any modification whatever to its products and to prices thereof in view of which, the Fourgroup S.r.l. is to be considered bound only by such details as appear in the relative Order Confirmation.
- 1.6. Fourgroup S.r.l.'s catalogues have been drawn up with the utmost attention in order to ensure the accuracy of information, however, Fourgroup S.r.l. declines responsibility for any errors or omissions contained in the same, as the Parties are only bound by the contents of Orders, Order Confirmation and these General Conditions of Sale.

## 2. Conclusion of the contract

- 2.1. The contract of sale shall only be considered as concluded with Fourgroup S.r.l.'s explicit acceptance thereof by means of the Order Confirmation issued by Fourgroup S.r.l..

## 3. Prices

- 3.1. The contract prices are those set forth in the Order Confirmation, and are to be considered as being for merchandise made ready by Fourgroup S.r.l. "ex-works" (EXW), according to Incoterms (International Commerce Terms).
- 3.2. Any amendment to the contract requested by the Buyer after its conclusion shall be null and void unless accepted in writing by Fourgroup S.r.l., specifying new terms of delivery, prices and terms of payment where applicable.

## 4. Delivery dates

- 4.1. The terms of delivery stated on the Order Confirmation are indicative, without prejudice to Fourgroup S.r.l.'s undertaking to observe the same as far as possible.
- 4.2. In any event, given the indicative nature of the terms of delivery, Fourgroup S.r.l. shall in no circumstances be held responsible for any direct or indirect damage to the Buyer on account of late delivery, unless shipment date has been guaranteed in a written way by Fourgroup Srl accepting an agreement with daily penalty clauses in case of delay.
- 4.3. Fourgroup S.r.l. is entitled to postpone the delivery deadline or suspend the delivery of the contractual material, at its unchallengeable discretion:
  - a) should the Buyer fail to observe the conditions of payment established or be late in fulfilling its contractual obligations (such as, by way of a non-limiting example, the sending of advances, granting of guarantees, issue and presentation of credit instruments and other financial fulfilments) including those relating to previous relations with Fourgroup S.r.l.;
  - b) force majeure and like instances, such as, by way of a non-limiting example strikes, lock-outs or abstention from labour, epidemic, war, requisition, fire, flood, processing incidents and stoppages and/or delays in transportation, blackout or inadequacy of power supplies and any other event that cannot be attributed to Fourgroup S.r.l. or its suppliers;
  - c) failure on the part of the Buyer to provide Fourgroup S.r.l., in good time, with any information it has undertaken to provide and necessary for the supply and/or materials to be delivered.
  - d) when amendments are made to the Order, even with Fourgroup S.r.l.'s acceptance;
  - e) in the event of difficulties in procurement of raw materials.
- In cases in which suspension of supplies or extension in delivery deadlines are due to causes that can be referred in any way to the Buyer (such as, by way of a non limiting example, those cases set forth in the previous paragraph under points a, c and d), Fourgroup S.r.l. shall be entitled to claim compensation from the Buyer for the damage suffered.
- 4.4 Delayed delivery shall not in any case entitle the Buyer to claim for compensation for damage.

## 5. Suspended or cancelled orders

- 5.1. In the event of the Buyer's suspending or cancelling an order, Fourgroup S.r.l. reserves the right to invoice the Buyer in respect of:
  - a) the cost, calculated pro-rata, of materials utilized and of work accomplished in filling the order thus far. The merchandise in this instance remaining at the Buyer's disposal;
  - b) increased expenditure ensuing to Fourgroup S.r.l. from the Buyer's failure to settle, in addition to 20% of the difference between the order sum-total and the amount previously arrived at by the application of point a).

## 6. Deliveries

- 6.1. Delivery is usually understood as ex-works (EXW) at Fourgroup S.r.l.'s premise.
- 6.2. Specifically, delivery may be said to have taken place, to all intents and purposes, with the sending of notice (which may simply take the form of an invoice) either to the effect that merchandise is available for collection by the Buyer, or to the effect that it has been handed over to the freight company.
- 6.3. Once notice has been received that the goods are ready, the Buyer must swiftly indicate the name of the freight company, when appointed by the same, which will collect the goods. The Buyer must also arrange insurance cover for transportation.
- 6.4. In case of the late collection of merchandise made ready by Fourgroup S.r.l. for any reason whatsoever not attributable to lack of goodwill on the part of Fourgroup S.r.l., the goods shall be considered delivered starting from the communication that the goods were ready for collection, with the following consequences:
  - a) Fourgroup S.r.l. shall be entitled to issue the relative invoice and claim fulfilment of the terms of payment established;
  - b) Fourgroup S.r.l. may package, transport or store the material at the Buyer's expense, without prejudice to its right to claim for any damage suffered, including the costs for warehousing, keeping and storage of the goods.

## 7. Payment

- 7.1. Payments must be remitted to Fourgroup S.r.l.'s place of business, and made in accordance with such conditions as are agreed; any remittance made at location or in manner differing therefrom, may not be deemed valid and shall consequently not have a redeeming effect for the Buyer
- 7.2 In the event of late payment at the agreed deadlines, Fourgroup S.r.l. shall be entitled to charge penalty interest pursuant to Legislative Decree no. 231 of 9th October 2002.
- 7.3. Any claims or disputes give no right to the Buyer to suspend or delay the payment of invoices.
- 7.4. The issue of bills of exchange, IOUs, drafts, cheques or any other form of payment or guarantee shall not cause any amendment to the contract or any of the contract clauses (specifically, it shall not change the place of jurisdiction in the case of a dispute) and shall be exclusively considered as aimed at facilitating the definition of the relationship, without having any novation effect.
- 7.5. Advance payment to Fourgroup S.r.l. shall always be non-interest bearing.

## 8. Freightforwarding

- 8.1. All transactions regarding transport, insurance, customs and excise, handling, and delivery are at the care, expense and risk of the Buyer, whose responsibility it is both to check the merchandise upon arrival and to make any claim against the freight company by direct approach, even where merchandise has been dispatched carriage-paid.
- 8.2. In those cases where Fourgroup S.r.l.'s transport facilities are utilized for shipping merchandise, the latter is to be dispatched, ex-works at best, with the Buyer duly assuming total responsibility thereof.

## 9. Claims

- 9.1. Any claim or contestation on the part of the Buyer with regard to merchandise supplied, must be forwarded in writing to Fourgroup S.r.l. within 8 working days of the date of delivery of the goods and sent to Fourgroup S.r.l.
- 9.2. In the event of claims for tampering with or shortage of goods, the Buyer shall promptly notify the freight company in writing at the time the goods are received.

## 10. Warranty

- 10.1. Fourgroup S.r.l. guarantees the good operation of the standard Fourgroup S.r.l. products for 12 months from the date of their dispatch. This warranty period could be extended and become 18 months if the goods have stand in our retailer's warehouses.
- 10.2. The warranty is limited to repair or replacement of parts at Fourgroup S.r.l.'s unchallengeable discretion, forwarded carriage-paid to an address specified Fourgroup S.r.l., which show recognizable defects due to defective materials or manufacturing. The parts replaced remain property of Fourgroup S.r.l..
- 10.3. The warranty does not cover parts that are subject to natural wear or deterioration (such as, by way of a non-limiting example, seal rings, fuse, filters, warning light).
- 10.4. No other compensation of any kind is envisaged by the warranty, neither can there be any question of claims for damages of any kind, direct or indirect, (including by third parties), even in respect of temporarily suspended use of the merchandise purchased. Examination of such defects and the causes thereof is to be carried out at one of Fourgroup S.r.l.'s factories, by Fourgroup S.r.l..
- 10.5 Expenses relating to operations (such as, for example, labour, dismantling, reassembly, transport, board and lodgings) by Fourgroup S.r.l.'s personnel to outside locations for the purpose, are chargeable to the Buyer, even in case the right to repairs under warranty has been acknowledged. Fourgroup S.r.l. will be chargeable only for the costs of replaced parts and the time needed to replace them.
- 10.6. The warranty ceases to be effective for products stored, installed utilized or maintained in a negligent or improper manner, i.e. not in accordance to Fourgroup S.r.l.'s instructions, or modified and/or repaired in any way whatsoever, or entirely or partially disassembled
- 10.7. The warranty also excludes damages and/or defects and/or abnormalities deriving from external components (such as, by way of a non-limiting example lightnings, atmospheric discharge etc.).
- 10.8. The warranty mentioned in article 10 replaces and excludes any other form of warranty, even legal.
- 10.9. The Buyer's entitlement to the warranty mentioned in this article shall be null and void in the case of non-performance of even just one of the contractual obligations assumed, specifically as regards the conditions of payment.
- 10.10. Any repairs under warranty and/or not under warranty are to be required in writing by the Buyer to Fourgroup Srl, writing the serial number of the product, defect claimed, mentioning purchasing document.
- 10.11. For replaced or repaired parts and for these alone, the warranty period recommences and void the same day of the expiry date of the warranty of the product or of electrical equipment.

## 11. Liability

- 11.1. Should Fourgroup S.r.l. be liable for faulty products, the compensation shall not in any case exceed the purchase price of the same faulty products.
- 11.2. Fourgroup S.r.l. shall not in any case be liable for indirect damage such as, for example, loss of clientele, turnover, production, profit, image or any damage to the Buyer for any action taken against it by third parties.
- 11.3. Fourgroup S.r.l. shall not in any case be liable when product defects are due, by way of a non-limiting example, to:
  - a) improper, incorrect or excessive use;
  - b) improper, incorrect or inadequate maintenance
  - c) product use that is unusual or contrary to Fourgroup S.r.l.'s warnings or, in any case, different to its intended use;
  - d) use of product with non-original components;
  - e) improper conservation

## 12. Applicable law, jurisdiction and place of jurisdiction

- 12.1. Any dispute concerning the stipulation, validity, interpretation, execution and termination of this agreement shall be governed by Italian Law and the court of Padova shall have sole jurisdiction, with the exclusive jurisdiction of the Italian judge, with the explicit exclusion of any other court.

## 13. Proprietorship of goods. Indemnity

- 13.1. The property of the goods forming the subject of this sale is of Fourgroup S.r.l. and shall be transferred to the Buyer only upon full payment of the agreed price by the Buyer pursuant to articles 1523 f. of the Italian Civil Code.
- 13.2. Non-payment within the established terms of even just one instalment amounting to over one eighth of the sale price or non-payment of two instalments regardless of the sum of the same, according to the agreed terms, shall automatically invalidate the Buyers' acceleration clause, with Fourgroup S.r.l. consequently being entitled to full and immediate payment, in a single settlement of the full residual credit.
- 13.3. Furthermore, when preferred by Fourgroup S.r.l., it shall be entitled to terminate the agreement and consequently obtain immediate return of the material delivered, withhold as indemnity, all the instalments paid and demand payment of the instalments expired and 3/5 (three fifths) of those yet to expire, without prejudice to compensation for further damage.

## 14. Form of the agreement

- 14.1. This agreement represents the only negotiation instrument governing relations between the Parties.
- 14.2. Any agreements to derogate, amend and/or supplement these General Conditions of Sale shall be stipulated and proven in writing.
- 14.3. The Buyer hereby agrees to have received and carefully examined the technical documentation provided by Fourgroup S.r.l., drawn up in Italian and English, regarding the material acquired.

## 15. Invalid clauses

- 15.1. The Parties hereby explicitly agree that the invalidity of one or more provisions of this agreement shall not affect the validity of the agreement as a whole.





**FOURGROUP S.r.l.**

Via Enrico Fermi, 8  
35020 Polverara (PD)  
ITALY

Tel. 0039 049 9772407

Fax 0039 049 9772408

[www.fourgroup.it](http://www.fourgroup.it)

[info@fourgroup.it](mailto:info@fourgroup.it)

Distribuito da  
Distributed by

Emissione / Issue: 06.12

**I dati tecnici possono essere modificati senza preavviso**  
***Technical details may be modified without notice***