

## FIRE-FIGHTING UNITS

50 Hz

### EBARA Pumps Europe network

#### HEAD OFFICE

**EBARA Pumps Europe S.p.A.**  
Via Pacinotti, 32  
36040 Brendola (VI), Italy  
Phone +39 0444 706811 - Fax +39 0444 405811

*Italian Sales (for order only):*  
e-mail: ordini@ebaraeurope.com

*Export Sales (for order only):*  
e-mail: exportsales@ebaraeurope.com

*Technical Customer Service (TCS):*  
e-mail: tcs@ebaraeurope.com  
Phone +39 0444 706869/902/923/833

*Marketing & Marketing Communication:*  
e-mail: marketing@ebaraeurope.com

#### ITALIAN SALES NETWORK

**NORTH-EAST Region:**  
(Trentino Alto Adige, Veneto, Friuli Venezia Giulia, Emilia Romagna)  
Regional Manager mobile: +39 335 6423308  
e-mail: nord@ebaraeurope.com  
Phone +39 0444 706811 - Fax +39 0444 405811

**NORTH-WEST Region:**  
(Valle d'Aosta, Piemonte, Lombardia, Liguria)  
Regional Manager mobile: +39 335 5327276  
e-mail: mrtgmi@ebaraeurope.com  
Phone +39 0444 706811 - Fax +39 0444 405975

**CENTRAL Region:**  
(Toscana, Umbria, Marche, Lazio, Abruzzo, Molise)  
Regional Manager mobile: +39 335 6423286  
e-mail: centro@ebaraeurope.com  
Phone +39 0444 706811 - Fax +39 0444 405811

**SOUTH Region:**  
(Campania, Basilicata, Puglia, Calabria, Sicilia)  
Regional Manager mobile: +39 335 6423316  
e-mail: sud@ebaraeurope.com  
Phone +39 0444 706811 - Fax +39 0444 405811

**INDUSTRIAL Division:**  
Manager mobile: +39 335 6423302  
e-mail: industry@ebaraeurope.com  
Phone +39 0444 706811 - Fax +39 0444 405811

**WASTEWATER Division:**  
Manager mobile: +39 335 6423290  
e-mail: ses@ebaraeurope.com  
Phone +39 0444 706811 - Fax +39 0444 405811

**CAGLIARI Branch:**  
Via del Fangario, 29  
09122 Cagliari  
Phone +39 070 274281 - Fax +39 0444 405960  
Branch Manager mobile: +39 335 6423320  
e-mail: mktgca@ebaraeurope.com

**PALERMO Branch:**  
Via Don L. Sturzo, 181/183  
Z.I. - 90044 Carini (PA)  
Phone +39 091 8669790 - Fax +39 0444 405980  
Branch Manager mobile: +39 335 6423316  
e-mail: mktgpa@ebaraeurope.com

#### EXPORT NETWORK

**EBARA Pumps Europe S.p.A. UNITED KINGDOM**  
Unit 7 - Zodiac Business Park  
High Road - Cowley Uxbridge  
Middlesex - UB8 2GU, United Kingdom  
Phone +44 1895 439027 - Fax +44 1895 439028  
e-mail: mktguk@ebaraeurope.com

**EBARA ESPAÑA BOMBAS S.A.**  
C/Cormoranes 6 Y 8  
Poligono Ind. La Estación  
28320 Pinto (Madrid), Spain  
Phone +34 916.923.630 - Fax +34 916.910.818  
e-mail: marketing@ebara.es

**EBARA Pumps Europe S.p.A. FRANCE**  
555, Rue Juliette Recamier  
69970 Chaponnay, France  
Phone +33 4 72769482 - Fax +33 805101071  
e-mail: mktgf@ebaraeurope.com

**EBARA Pumps Europe S.p.A. GERMANY**  
Ferdinand-Porsche-Ring 7  
63110 Rodgau-Jügesheim, Germany  
Phone +49 (0) 6106-660 99-0  
Fax +49 (0) 6106-660 99-45  
e-mail: mktgd@ebaraeurope.com

**EBARA POMPY POLSKA Sp. z o.o.**  
ul. Działkowa 115  
02-234 Warszawa, Poland  
Phone +48 22 3909920 - Fax +48 22 3909929  
e-mail: mktgpl@ebaraeurope.com

**EBARA Pumps Europe S.p.A. SAUDI ARABIA**  
Phone +966 11 810 4561  
Fax +966 11 810 4562

**EBARA Pumps Europe S.p.A. INDIA LIAISON OFFICE**  
1503, Bhumiraj Costarica,  
Sector-18, Palm Beach Rd.  
Sanpada, Navi Mumbai  
Maharashtra, Pin: 400705 - India  
Phone +91 22 2781 2862  
Fax +91 22 2781 2865  
e-mail: mktgind@ebaraeurope.com

**EBARA Pumps RUS Ltd.**  
Prospekt Andropov 18, building 7, floor 11  
115432 Moscow  
Phone +7 499 6830133  
e-mail: mktgrus@ebaraeurope.com



#### EBARA Pumps Europe S.p.A.

Via Pacinotti, 32  
36040 Brendola (Vicenza), Italy  
Phone +39 0444 706811 - Fax +39 0444 405811  
e-mail: marketing@ebaraeurope.com  
www.ebaraeurope.com



#### EBARA Corporation

11-1, Haneda Asahi-cho, Ohta-ku,  
Tokyo 144-8510  
Japan  
Phone +81 3 6275 7598 - Fax +81 3 5736 3193  
www.ebara.com





# INDEX

## ***FIRE-FIGHTING***

	<b>Overview of Standard UNI EN 12845</b>	2
	<b>Fire-Fighting introduction</b>	4
	<b>FFS-FFBE electric pump</b>	14
	<b>FFBD motor pump</b>	38
	<b>FFBD electric pump + motor pump</b>	43
<b>BASE-JOINT PUMPS (3PS - ENRS)</b>		
	<b>FFS-S hydraulic kits</b>	46
<b>BOREHOLE PUMPS (SF6 - WINNER 4N15 - BHE)</b>		
	<b>Cabinets</b>	63
<b>WITH EXTERNAL PROTECTION R60</b>		
	<b>Electrical panels</b>	64

## INTRODUCTION TO STANDARD EN 12845

### Introduction

System standard UNI EN 12845 regulates the design, installation and maintenance of fixed sprinkler fire extinguishing systems.

The pump unit indicated in section 10 of the standard is comprised of: a supply pump that meets the system's specifications (or several pumps operating in parallel), and a jockey pump for small system leaks.

The operation of the supply pump, which may be electrical or diesel-fuelled, is governed by Standard UNI EN 12845 point 10.2, based on the type of water supply.

As required by the standard, the EBARA supply pumps used in FFS-FFB pumping units, are fitted with motors that provide: the power required at the peak of the power curve in the event of pumps with non-overloading curves; for pumps with power curves that increase with the flow rate, however, they provide the power required up to a flow rate that corresponds with a NPSH pump demand of no less than 16 m.

In the first instance (Fig.1) the power peak may occur within the operating range (curve A) or outside it (curve B).

In the second instance (Fig.2), the power curve increases in line with the flow rate (curve C). The motor is selected based on a flow rate that corresponds with a pump NPSHr of 16 m or greater.

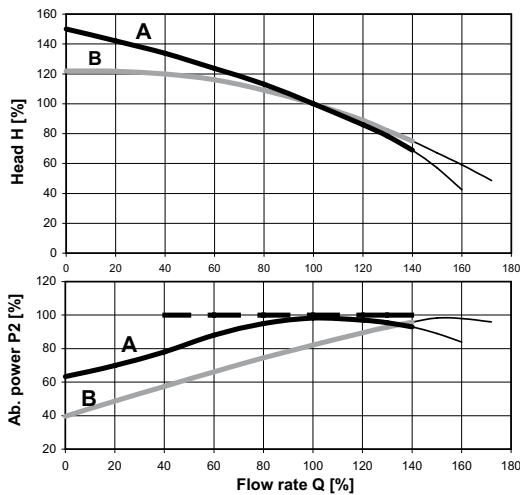

Fig. 1 – Definition of the power requested on the basis of the peak value

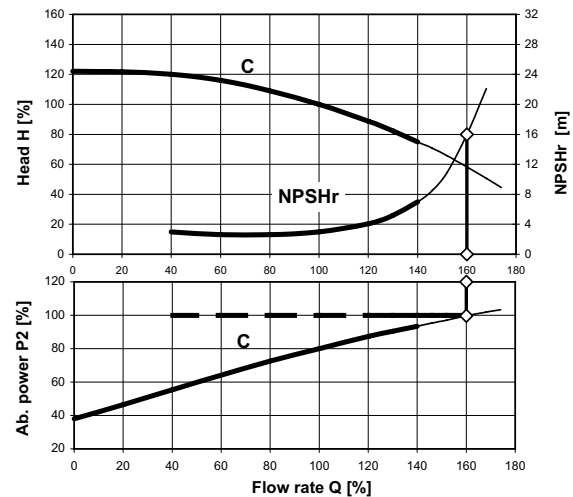

Fig. 2 – Definition of the power requested on the basis of the NPSH

### Hazard classes

(UNI EN 12845 paragraph 6 and annex A)

The hazard class and water supply class (described below), are chosen by the designer of the fire extinguishing system.

The standard requires that fire-extinguishing systems that protect businesses and buildings are designed and built in accordance with hazard classes, which are divided into three types:

- Light Hazard - LH;
- Ordinary Hazard - OH, divided into the categories: OH1, OH2, OH3, OH4
- High Hazard - HH, divided into the categories:
  - > High Hazard, Process - HHP, in turn divided into the categories:
    - HHP1 - High Hazard - Process Group 1
    - HHP2 - High Hazard - Process Group 2
    - HHP3 - High Hazard - Process Group 3
    - HHP4 - High Hazard - Process Group 4
  - > High Hazard, Storage - HHS, in turn divided into the categories:
    - HHS1 - High Hazard - Storage Category I
    - HHS2 - High Hazard - Storage Category II
    - HHS3 - High Hazard - Storage Category III
    - HHS4 - High Hazard - Storage Category IV

### Type of water supply used

Mains water supplies should automatically provide the pressure and flow rate required by the system and should be able to ensure continuity and reliability.

The standard recognises four different types of water supply (UNI EN 12845 paragraph 9.6):

- Single water supplies (9.6.1);
- Superior single water supplies (9.6.2);
- Dual water supplies (9.6.3);
- Combined water supplies (9.6.4);

In a UNI EN 12845 fire-extinguishing pumping system, in the event of "Superior or dual water supplies", no more than one supply pump should be operated by an electric motor (point 10.2). In practice, if a unit with several supply pumps is installed on one of these water supply systems, only one of them is operated by an electric motor, the others are operated by diesel motors.

## INTRODUCTION TO STANDARD EN 12845

### Performance specifications - Pre-calculated systems

The system performance specifications for selecting the pumps must comply with that set out in paragraph 10.7 of Standard UNI EN 12845. Statement 16 of the Standard sets out the minimum specifications for pressure and flow rate, based on pre-calculated systems for hazard classes LH and OH, with water drawn from storage tanks.

For pre-calculated systems in hazard classes HHP-HHS, the pump specifications are defined in accordance with paragraph 7.3.2 of Standard UNI EN 12845. In these instances the pump must be able to supply 140% of the flow rate at a pressure of no less than 70% of the specified pressure at the pump's rated flow rate.

The choice of performance specifications and the number of pumps installed is the responsibility of the system designer.

### Operating principle

The supply pump in the UNI EN 12845 fire-extinguishing pumping unit, in the event it is triggered, is started by the operation of two pressure switches controlled by the electrical control panel (each pump has its own electrical panel), and must operate continuously until it is stopped. This can only take place manually (UNI EN 12845 10.7.5.2). The activation of the supply pump simultaneously causes the activation of an acoustic alarm signal via an alarm remote control unit installed in a manned area.

The jockey pump, with a low flow rate, is activated in the event of small leaks in the system (in order to prevent the supply pump from activating needlessly). It is activated automatically via its own electrical control panel and associated pressure switch, which is calibrated to a pressure value slightly higher than that of the supply pump pressure switch. The jockey pump is stopped automatically once the system pressure is restored.

### Standards and directives

- UNI EN 12845, fixed fire-extinguishing systems - automatic sprinkler systems
- UNI 10779, fire-extinguishing systems - hydrant lines
- UNI EN ISO 9906 Attachment A - Rotodynamic pumps - Hydraulic performance tests and acceptance criteria
- Machinery Directive 2006/42/CE
- Low Voltage 2006/95/CE
- Electromagnetic Compatibility 2004/108/CE

### General conditions of use

Use:

- Fixed fire-extinguishing systems, automatic sprinkler systems in accordance with Standard UNI EN 12845
- Fire-extinguishing systems, hydrant lines in accordance with Standard UNI 10779

Area of installation and operation:

- Dedicated area for pumping unit, enclosed and protected, with a level of fire resistance of no less than 60 minutes (UNI EN 12845 point 10.3)
- Protected via sprinkler (UNI EN 12845 point 10.3.2)
- The pumping unit should not be positioned in buildings or parts of buildings where dangerous processes or explosion risks are present (UNI EN 12845 point 8.4)
- Protected from frost (UNI EN 12845 point 8.4)
- Protected from tampering (UNI EN 12845 point 8.4)

Ambient temperature:

- The ambient temperature for operation is 4°- 40°C for electrical pumps at an altitude of no higher than 1000m a.s.l.
- Ambient temperature for motor pumps is +10°- 40°C
- Max. relative humidity is 50% at +40°C

Temperature of water supply:

- The temperature of the channelled water should be 0°- 40°C
- The temperature of the channelled water should be 0°- 25°C if submerged pumps are used

The channelled water should be free of fibrous substances or other suspended materials or vegetation which could cause deposits inside the pipes (UNI EN 12845 point 8.1.2).

The water pressure should not exceed 12 bar, except in systems with a high vertical trend (difference in height between highest and lowest sprinkler > 45 metres)

(UNI EN 12845 8.2.1, 8.2.2).

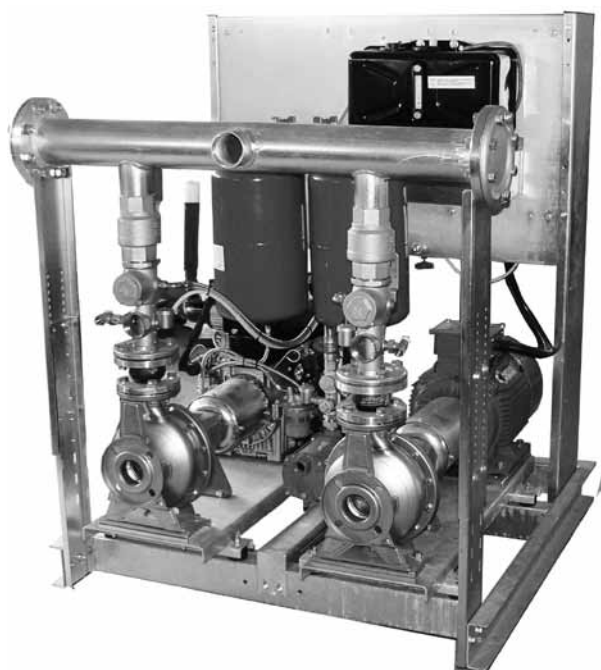

### FFS - FFB UNI EN 12845 FIRE-FIGHTING UNITS

EBARA type FFS-FFB fire-extinguishing units are applied to water supplies for automatic fire-extinguishing systems in accordance with European Standard UNI EN 12845.

#### APPLICATIONS:

The units are suitable for water supply and pressure boosting in automatic sprinkler systems, fire hydrants or fire hoses or for controlling the same.

#### DESCRIPTION

These water supply units for fire-extinguishing systems are built in accordance with Standard EN 12845. Based on the model, they are comprised of from 1 to 3 base-joint horizontal pumps – EN 733 – coupled together via an elastic spacer joint with associated joint cover. The pumps have electrical/diesel motors and a jockey pump.

#### GENERAL TECHNICAL DATA

##### Usable liquids

Clean water with no aggressive or fibrous substances or other suspended abrasive material.

##### Field of use

- Fluid temperature range: +25 to +40 °C
- Min. ambient temperature 4 °C (10°C)
- Max. operating pressure 12 bar

##### Electrical motor for main/reserve pump

- Self-ventilating asynchronous three-phase enclosed motor with external self-ventilation
- 2900 rpm
- Protection rating IP 55
- Insulation Class F
- Main power supply 400V
- Voltage 50 Hz

##### Endothermic diesel motor

- Direct injection or turbocharged; start-up without preheating
- Forced lubrication with geared pump
- Full-flow oil filter
- Oil pre-heater for cold starting at maximum power, located under the casing
- Cooling (based on power rating): air-cooled with dual drive belt, glycol water-cooled with closed-loop radiator; with water/water heat exchanger on request
- Electrical start-up via dual battery able to reach full power within 15 seconds from any sequence at a minimum temperature of 10 °C in the pumping area

##### Electrical motor for jockey pump

- Three-phase asynchronous motor with external self-ventilation with squirrel cage rotor
- 2900 rpm
- Insulation Class F
- Main power supply 400V
- Voltage 50 Hz

#### MAIN MATERIALS OF MAIN/RESERVE PUMP ENR

- Pump body made of cast iron
- Impeller made of cast iron
- Shaft made of AISI 420 steel
- Mechanical seal made of SiC/Carbon/EPDM

#### 3 SERIES

- Pump body made of AISI 304 steel
- Impeller made of AISI 304 steel
- Shaft made of AISI 304 steel
- Mechanical seal made of Ceramics/Carbon/NBR

#### MAIN MATERIALS FOR JOCKEY PUMP

##### AGA

- Pump body made of cast iron
- Impeller made of brass
- Shaft made of AISI 303 steel (part in contact with liquid)
- Mechanical seal made of Ceramics/Carbon/NBR

##### COMPACT

- With pump in polypropylene reinforced with glass fibre
- Impeller made of Noryl
- Shaft made of AISI 316 steel
- Mechanical seal made from graphite/ceramics

##### MATRIX

- Pump body made of AISI 304 steel
- Impeller made of AISI 304 steel
- Shaft made of AISI 304 steel (part in contact with liquid)
- Standard mechanical seal made from Ceramics/Carbon/EPDM

#### MATERIALS USED FOR METAL STRUCTURE

- The base is made from zinc-plated section steel
- The manifolds are made from zinc-plated steel
- Throttle-type shut-off valves (made from EN GJL 250 treated cast iron)
- Inspectable clapet-type non-return valves (made from EN GJL 250 treated cast iron)

## FIRE-FIGHTING UNITS

### GENERAL TECHNICAL DATA

#### Use

Water supply and water pressure boosting in residential, commercial and public buildings, hotels, hospitals, supermarkets, and in industrial and process applications. With water for fire-extinguishing use with no aggressive chemical or mechanical agents that could damage the materials used and with no suspended abrasive or fibrous substances.

#### Operation

The system is kept under pressure without the need to start the main pump via a jockey pump with automatic start-up and shut-off via pressure switch. This pump is sized so as not to be able to provide sufficient pressure and flow rate to supply a single open sprinkler. In the event that the pressure is lowered following a demand for water that cannot be compensated for by the jockey pump, the main pump and emergency pump (where fitted) are activated in sequence. Both these pumps are activated automatically and shut-off manually via a switch on the control panel.

#### Build

Preassembled unit with a single base up to 90 kW, made from welded and coated strong section steel, with support feet for facilitating handling. Based on the type of build, the unit is comprised of the following:

#### • Main pump

Horizontal axis base-joint normalised unidirectional centrifugal pump with end suction and back pull out axial suction and radial delivery. This is coupled to an oversized electrical or endothermic motor that exceeds the power demand of pump under any load condition, from zero load to a flow rate equal to an NPSHr of 16 mca, in accordance with Standard EN 12845. The coupling is achieved via a lantern, support, flexible joint with spacer, alignment support and anchor.

#### • Included motor pump accessories

- 2 batteries
- 1 fuel tank (with a capacity suitable for the specific requirements), with fuel level indicator and collection basin (up to 16L). For larger sizes the tank is equipped with a dual chamber
- 1 manual pump for loading fuel (tank capacity >50 l)
- 1 engine oil gauge

#### • Jockey pump

Horizontal multi-stage pump or self-priming pump with suitable performance to maintain system pressure, from the AGA, COMPACT or MATRIX range.

#### • Control panels

Built in accordance with applicable CEI Standards and Standards UNI EN 12845 and UNI 10779 for the main/jockey pumps, in coated sheet metal casing. Protection grade IP 54. Each pump is equipped with a control panel housed on a dedicated support (this can be separate on request for wall installation)

#### • Electrical panel for electric pump

On the front panel: door lock main switch with suitable "machine stop" knob; electronic control unit for managing electric pump in accordance with Standards UNI EN 12845 and UNI 10779:

- Auto - 0 - Man. selector key with safety shut-off
- Shutdown signal
- Failed start-up signal
- Pump operating signal
- Power supply signal
- Phase sequence/failure signal
- Start-up request signal
- 1 lamp test button
- 1 manual operation button
- 1 pump shut-off button
- 1 status information graphic display
- transformer for low voltage auxiliary circuits.
- start-up contactor (direct up to 7.5 kW, star-delta for higher power ratings).
- high blow potential protection fuses that allow for the passage of starting current within 20 seconds
- detection system for phase failure or inverted phase conditions.
- clean contacts for remote signalling: pump in operation, phase failure, start-up request, start-up failure, electrical power supply present.

#### Motor pump electrical panel

On the front panel: door lock main switch with suitable "machine stop" knob; electronic control unit for managing motor pump in accordance with Standards UNI EN 12845 and UNI 10779:

- Auto - 0 - Man. selector key with safety shut-off
- 1 power supply indicator light
- 1 manual operation enablement indicator light
- 1 independent manual operation button (single button for emergency start-up associated with a power diode to avoid the influence of one start-up battery on another)
- 1 Diesel motor shut-off button
- Inside
  - Transformer for low voltage auxiliary circuits
  - Protection fuses
  - Clean contacts for remote signalling:
  - Pump in operation
  - Motor pump general alarm
  - Start-up request
  - Start-up failure
  - 2 battery chargers (dedicated to each individual battery)

#### Jockey pump electrical panel

On the front panel:

- Auto - 0 - Man. selector
- thermal shutdown red indicator light (and voltage present indicator based on the model)
- pump in operation green (or yellow, based on model) indicator light
- door lock main switch with suitable "machine stop" knob
- Inside:
  - transformer
  - direct start-up contactor
  - thermal relay
  - protection fuses

#### Pressure-switch circuits

- 2 circuits comprised of a dual-stage pressure switch, pressure gauge, pressure gauge holder, non-return valve, tap, both for the main pump and emergency pump, for automatic start-up.
- 1 pressure switch for the automatic start-up and shut-off of the jockey pump.

## FIRE-FIGHTING UNITS

### Expansion cones

Concentric cones inserted onto the delivery column to limit the speed within the parameters set out by the standard.

### Ball-type or throttle-type valves

Can be locked, with position indicator, on the delivery column, in combination with the concentric cone. ON/OFF status monitoring device included.

### Non-return valves

Clapet-type valves that can be inspected, fitted onto the delivery column.

### Vibration-damping joints

On the delivery column in the event of a diesel motor.

### Stub pipe for flow rate gauge attachment

On the delivery manifold with a suitable ND. (included in the flow rate gauge kit, see accessories)

### Recirculation circuit

Attachments for continuous water flow circuit to prevent overheating with the pump operating with the delivery line closed, complete with calibrated diaphragm fitted to the main pump delivery line.

### Attachments for priming reservoir

In accordance with Standard UNI EN 12845, fitted to the delivery column, obligatory for overhead installations.

### ACCESSORIES

- Suction eccentric reducer with max. inclination of 20°
- Lug valve with limit switch contact, version with lever handle or handwheel based on unit model
- Flow rate gauge kit
- 500 litre horizontal priming reservoir (one for each service pump), with mechanical float valve and electrical float for filling command via service pump.
- Vibration-damping joint kit
- Remote panel for alarm notifications
- Spare parts kit for diesel motors
- Water/water heat exchanger kit

## HYDRAULIC DIAGRAM SHOWING OVERHEAD SURFACE PUMPS

### KEY

- 1 Supply pump
- 2 Jockey pump
- 3 Throttle-type shut-off valve
- 4 Pump supply tank
- 6 Ball-type shut-off valve
- 7 Recirculation circuit attachment
- 8 Pressure gauge
- 9 Automatic air relief valve
- 10 Non-return valve
- 11 Blind flange/closure cap
- 12 Pump control pressure switch
- 13 Membrane-based expansion vessel
- 14 Gauge attachment
- 15 Extension stub pipe upstream of gauge
- 16 Flow rate gauge
- 17 Filter
- 18 Pump priming reservoir
- 19 Low-level switch for pump start-up
- 20 Base valve

**N.B.:** Components marked with an asterisk are supplied separately on request (\*3, \*15, \*16, full flow rate measuring kit) (13 expansion vessel), fitting and testing to be carried out by the manufacturer of the fire-extinguishing system.

**N.B.:** Components given between brackets and the associated mains water supplies marked with a dotted line are not part of the pressure boosting unit. These are the responsibility of the manufacturer of the fire-extinguishing system.

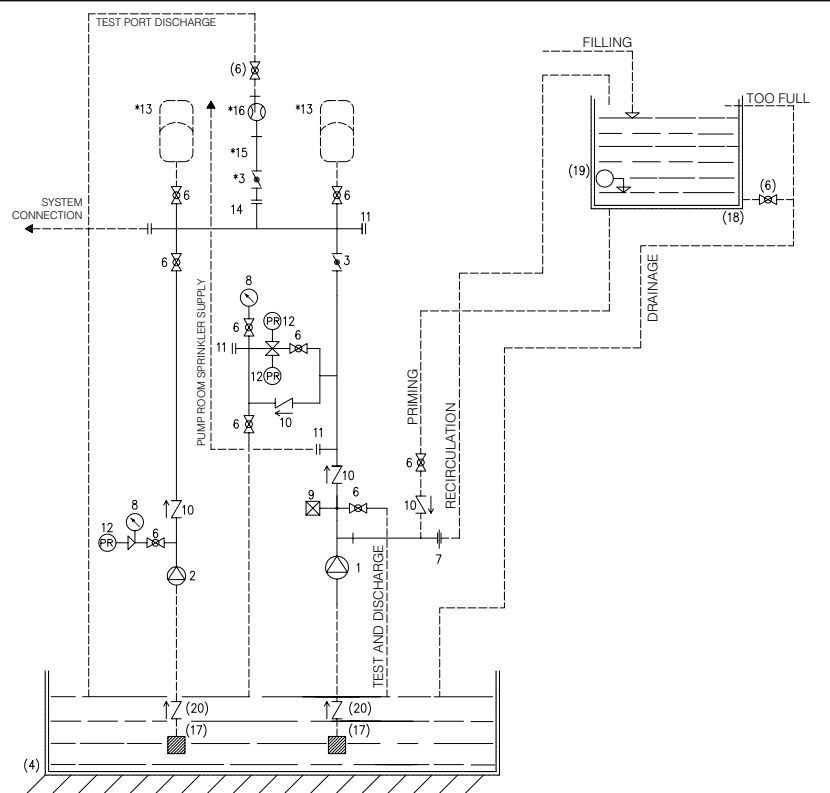

### HYDRAULIC DIAGRAM SHOWING UNDERHEAD SURFACE PUMPS

**KEY**

- 1 Supply pump
- 2 Jockey pump
- 3 Throttle-type shut-off valve
- 4 Pump supply tank
- 6 Ball-type shut-off valve
- 7 Recirculation circuit attachment
- 8 Pressure gauge
- 9 Automatic air relief valve
- 10 Non-return valve
- 11 Blind flange/closure cap
- 12 Pump control pressure switch
- 13 Membrane-based expansion vessel
- 14 Gauge attachment
- 15 Extension stub pipe upstream of gauge
- 16 Flow rate gauge
- 17 Filter

**N.B.:** Components marked with an asterisk are only supplied separately on request (\*3, \*14, \*15, \*16, full flow rate measuring kit) (\*13 expansion vessel). Fitting and testing are to be carried out by the manufacturer of the system.

**N.B.:** Components given between brackets and the associated mains water supplies marked with a dotted line are not part of the fire-extinguishing pressure boosting unit. These are the responsibility of the manufacturer of the fire-extinguishing system.

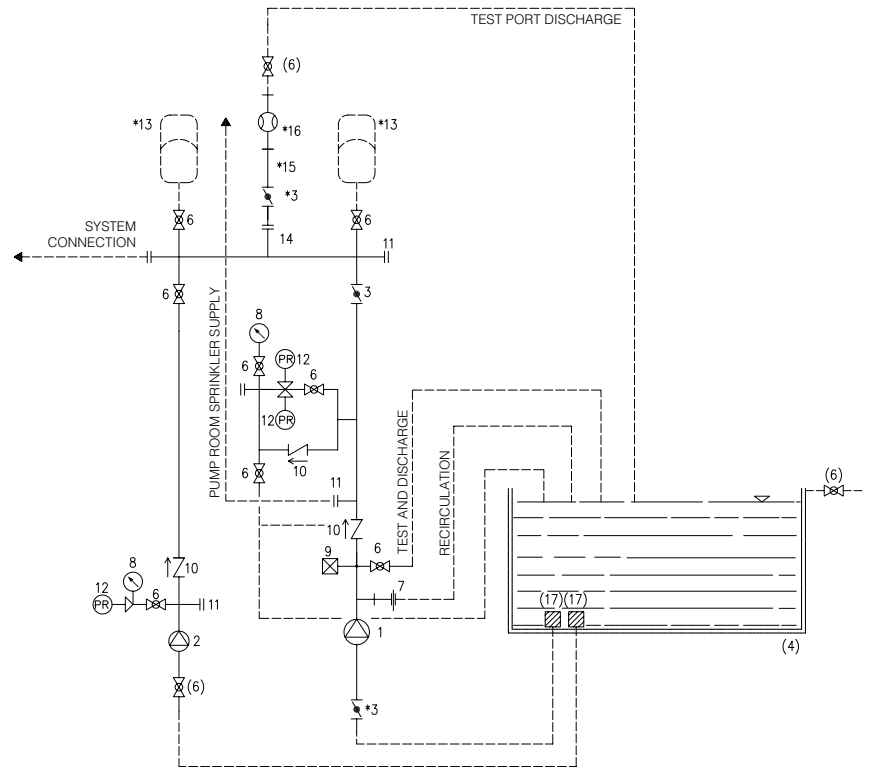

### HYDRAULIC DIAGRAM SHOWING SUBMERGED PUMPS

**KEY**

- 1 Supply pump
- 2 Jockey pump
- 3 Throttle-type shut-off valve
- 4 Pump supply tank
- 5 -
- 6 Ball-type shut-off valve
- 7 Recirculation circuit attachment
- 8 Pressure gauge
- 9 Automatic air relief valve
- 10 Non-return valve
- 11 Blind flange/closure cap
- 12 Pump control pressure switch
- 13 Membrane-based expansion vessel
- 14 T connector, measurement attachment
- 15 Extension stub pipe upstream of gauge
- 16 Flow rate gauge
- 17 Safety valve
- 18 Minimum-level switch for pump start-up
- 19 Float valve for filling

**N.B.:** Accessories and sections of pipe from the mouth of the pump outlet up to the connectors upstream of the clapet valves, including electrical connections, are the responsibility of the manufacturer of the fire-extinguishing system.

**N.B.:** Components marked with an asterisk are supplied separately on request (\*3,\*14,\*15,\*16, full flow rate measuring kit) (\*13 expansion vessel) (\*17, safety valve). Fitting and testing are to be carried out by the manufacturer of the fire-extinguishing system.

**N.B.:** Components given between brackets and the associated mains water supplies marked with a dotted line are not part of the pressure boosting unit. These are the responsibility of the manufacturer of the fire-extinguishing system

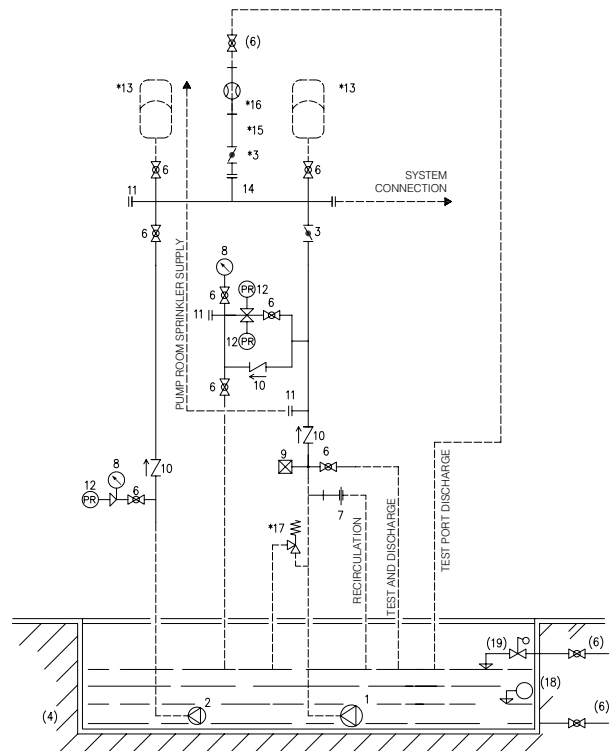

### DIAGRAM OF FFS FIRE-FIGHTING UNIT WITH BASE-JOINT ELECTRICAL PUMPS

#### KEY

- 1 Connector upstream of non-return valve
- 2 Inspectable clapet-type non-return valve
- 3 Connection stub pipe
- 4 Throttle-type shut-off valve with electrical signal for failure to open
- 5 Delivery manifold
- 6 Connection pipe for jockey pump (not provided for submerged pumps)
- 7 T connector, jockey pump line
- 8 Inspectable clapet-type non-return valve, jockey pump line
- 9 Ball-type shut-off valve, jockey pump line
- 10 Ball-type shut-off valve
- 11 Automatic air relief valve
- 14 Angle valve / diaphragm, recirculation circuit
- 15 /15A Closure cap / Priming kit
- 16 /16A Closure cap / Set-up for pump room sprinkler supply attachment
- 18 Pressure switch test circuit valves
- 19 Supply electrical pump start-up pressure switches
- 24 Pressure gauge, pressure switch circuit
- 25 Pressure gauge, jockey pump line
- 26 Ball-type shut-off valve, jockey pump pressure switch circuit
- 27 Jockey pump start-up pressure switch
- 28 Blind flange
- 29 Counter flange
- 30 Electrical control panel for supply electrical pump
- 31 Electrical control panel for jockey electrical pump
- 32 Alarm panel for manned area
- 33 Alarm siren control unit
- 34 Expansion vessel
- (\*) Supply pump flow rate gauge kit
- 36 (\*) Stabilising stub pipe
- 37 (\*) Shut-off valve
- 38 Flow meter
- 39 Electrical supply pump (supplied separately for submerged pump unit kits)  
Conical diffuser for reducing pump delivery speed (for units with 3PS pumps)
- 40 Counter flange (for submerged pump unit kits)
- 41 Jockey pump (supplied separately for submerged pump unit kits)
- 43 (\*) Eccentric conical diffuser (not provided for submerged pump unit kits)
- 44 (\*) Throttle-type shut-off valve for suction with electrical signal for failure to open (excluding submerged pumps)  
(\*) Priming kit (not provided for submerged pump unit kits)
- 45 Ball-type shut-off valve
- 46 Priming kit clapet-type non-return valve
- 47 Base (not provided for submerged pump unit kits)
- 48 Frame
- 49 Eyebolts for lifting
- 50 3-piece connector, jockey pump line
- 51 Attachment for flow rate gauge

ALARM CONTROL UNIT

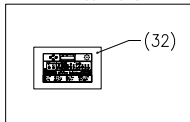

SUCTION CONE

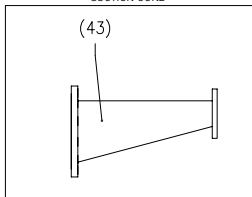

(\*) FLOW RATE GAUGE KIT

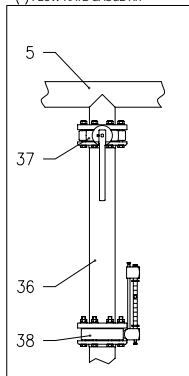

(\*) PRIMING KIT

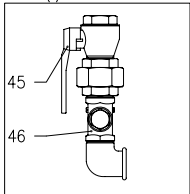

SUCTION VALVE

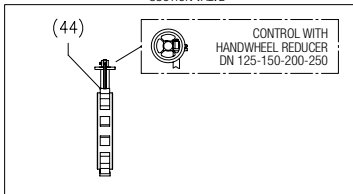

PUMP CONTROL PANELS

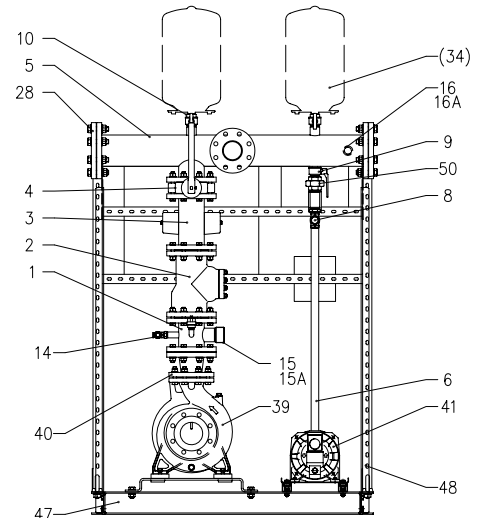
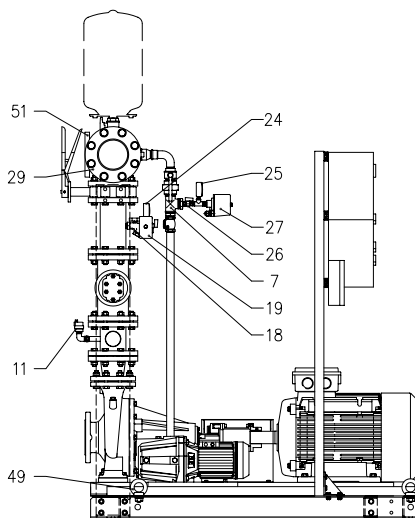
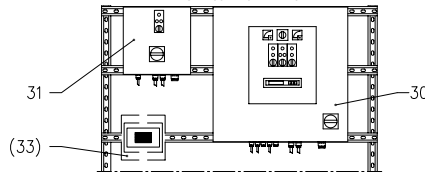

The contents of this publication should not be regarded as binding. EBARA Pumps Europe S.p.A. reserves the right to effect any modification it deems necessary, without prior notice.

### DIAGRAM OF FFB FIRE-FIGHTING UNIT WITH ELECTRICAL PUMP AND BASE-JOINT MOTOR PUMP

#### KEY

- |        |  |     |  |
|--------|--|-----|--|
| 1      | Vibration-damping joint  | 27  | Jockey pump start-up pressure switch   |
| 2      | Inspectable clapet-type non-return valve                       | 28  | Blind flange   |
| 3/3A-  | Blind flange (cap)/ flow rate gauge kit                        | 29  | Counter flange   |
| 4      | Shut-off valve with electrical signal for failure to open      | 30  | Electrical control panel for supply motor pump   |
| 5      | Delivery manifold  | 30A | Electrical control panel for supply electrical pump  |
| 6      | Jockey pump connection pipe                                    | 31  | Electrical control panel for jockey electrical pump  |
| 7      | Connector with closure cap, jockey pump line                   | 32  | (*) Alarm panel for manned area  |
| 8      | Inspectable clapet-type non-return valve, jockey pump line     | 33  | (*) Alarm siren control unit   |
| 9      | Ball-type shut-off valve, jockey pump line                     | 34  | (*) Expansion vessel   |
| 10     | Ball-type shut-off valve for expansion vessels                 | (*) | Supply pump flow rate gauge kit  |
| 11     | Automatic air relief valve                                     | 36  | Stabilising stub pipe  |
| 12     | T connector, recirculation circuit                             | 37  | Shut-off valve   |
| 13     | Pressure switch test circuit non-return valve                  | 38  | Flow meter   |
| 14     | Angle valve / diaphragm, recirculation circuit                 | 39  | Supply motor pump  |
| 15/15A | Closure cap / Priming kit                                      | 39A | Supply electrical pump   |
| 16/16A | Closure cap / Set-up for pump room sprinkler supply attachment | 40  | Conical diffuser for reducing pump delivery speed  |
| 17     | T connector, pressure switch test circuit                      | 41  | Jockey pump  |
| 18     | Ball-type shut-off valve, pressure switch outlet circuit       | 42  | Ball-type shut-off valve, jockey pump suction line   |
| 19     | Supply electrical pump start-up pressure switches              | 43  | (*) Eccentric conical diffuser   |
| 20     | Closure cap connector, pressure switch test circuit            | 44  | (*) Throttle-type shut-off valve with electrical signal for failure to open (supply pump suction line) |
| 21     | Fuel tank  | (*) | Priming kit  |
| 22     | Collection tank  | 45  | Ball-type shut-off valve   |
| 23     | Batteries  | 46  | Priming kit clapet-type non-return valve   |
| 24     | Pressure gauge, pressure switch test circuit                   | 47  | Base   |
| 25     | Pressure gauge, jockey pump line                               | 48  | Manifold supports  |
| 26     | Ball-type shut-off valve, jockey pump pressure switch circuit  | 49  | 3-piece connector, jockey pump line  |

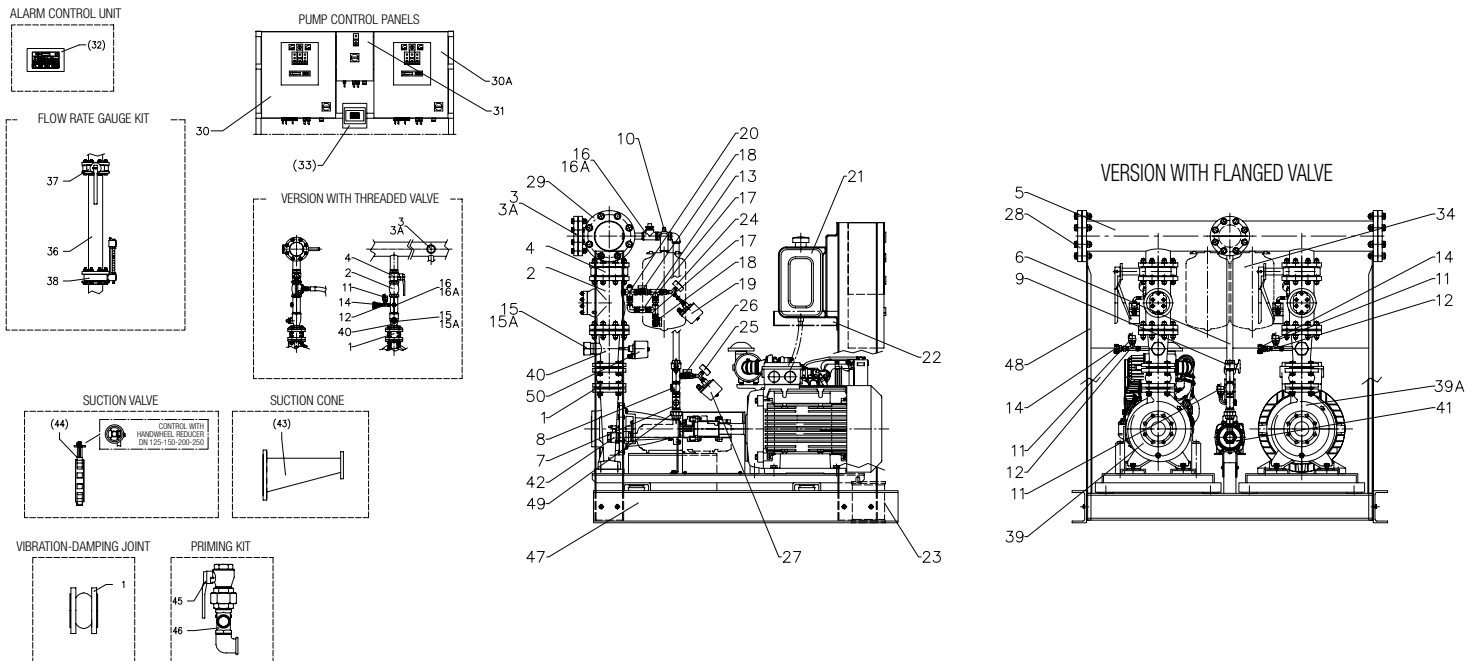

### DIAGRAM OF FFS-S FIRE-FIGHTING UNIT KIT WITH SUBMERGED ELECTRICAL PUMPS

#### KEY

- |   |  |
|---|--|
| 1 Connector upstream of non-return valve                                  | 26 Ball-type shut-off valve, jockey pump pressure switch circuit |
| 2 Inspectable clapet-type non-return valve                                | 27 Jockey pump start-up pressure switch                          |
| 3 Connection stub pipe  | 28 Blind flange  |
| 4 Throttle-type shut-off valve with electrical signal for failure to open | 29 Counter flange  |
| 5 Delivery manifold   | 30 Electrical control panel for supply electrical pump           |
| 7 T-connector, jockey pump line   | 31 Electrical control panel for jockey electrical pump           |
| 8 Inspectable clapet-type non-return valve, jockey pump line              | 32 (*) Alarm control unit for manned area                        |
| 9 Ball-type shut-off valve, jockey pump line                              | 33 (*) Alarm siren control unit                                  |
| 10 Ball-type shut-off valve   | 34 (*) Expansion vessel  |
| 11 Automatic air relief valve   | (*) Supply pump flow rate gauge kit                              |
| 14 Angle valve / diaphragm, recirculation circuit                         | 36- Stabilising stub pipe  |
| 15 /15A- Closure cap / Priming kit  | 37- Shut-off valve   |
| 16 /16A- Closure cap / Set-up for pump room sprinkler supply attachment   | 38- Flow meter   |
| 18 Ball-type shut-off valve, pressure switch test and outlet circuit      | 40 Counter flange  |
| 19 Supply electrical pump start-up pressure switches                      | 48 Frame   |
| 24 Pressure gauge, pressure switch test circuit                           | 49 Eyebolts for lifting  |
| 25 Pressure gauge, jockey pump line                                       | 50 3-piece connector, jockey pump line                           |
|   | 51 Attachment for flow rate gauge                                |

ALARM CONTROL UNIT

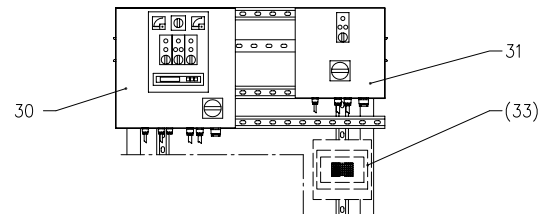
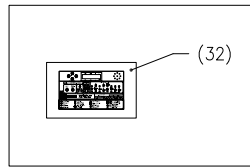

(\*) FLOW RATE GAUGE KIT

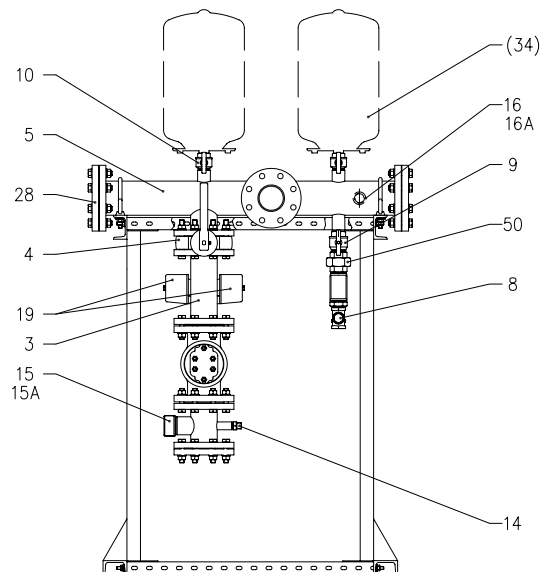
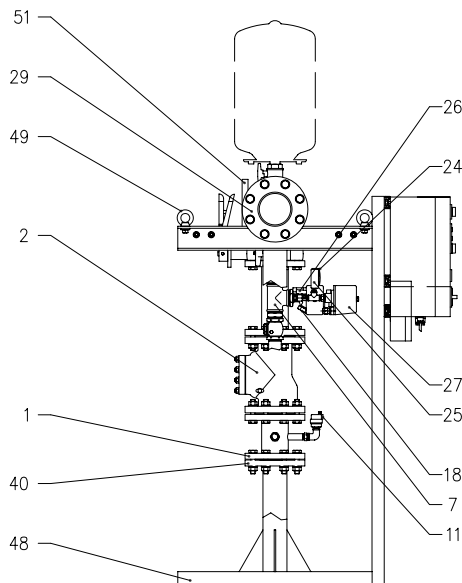
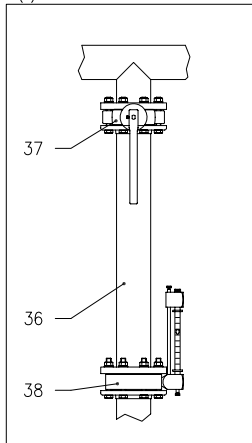

The contents of the publication should not be regarded as binding. EBARA Pumps Europe S.p.A. reserves the right to effect any modification it deems necessary, without prior notice.

### FFS-FFB FIRE EXTINGUISHING UNIT CONFIGURATION IN ACCORDANCE WITH STANDARD UNI EN 12845

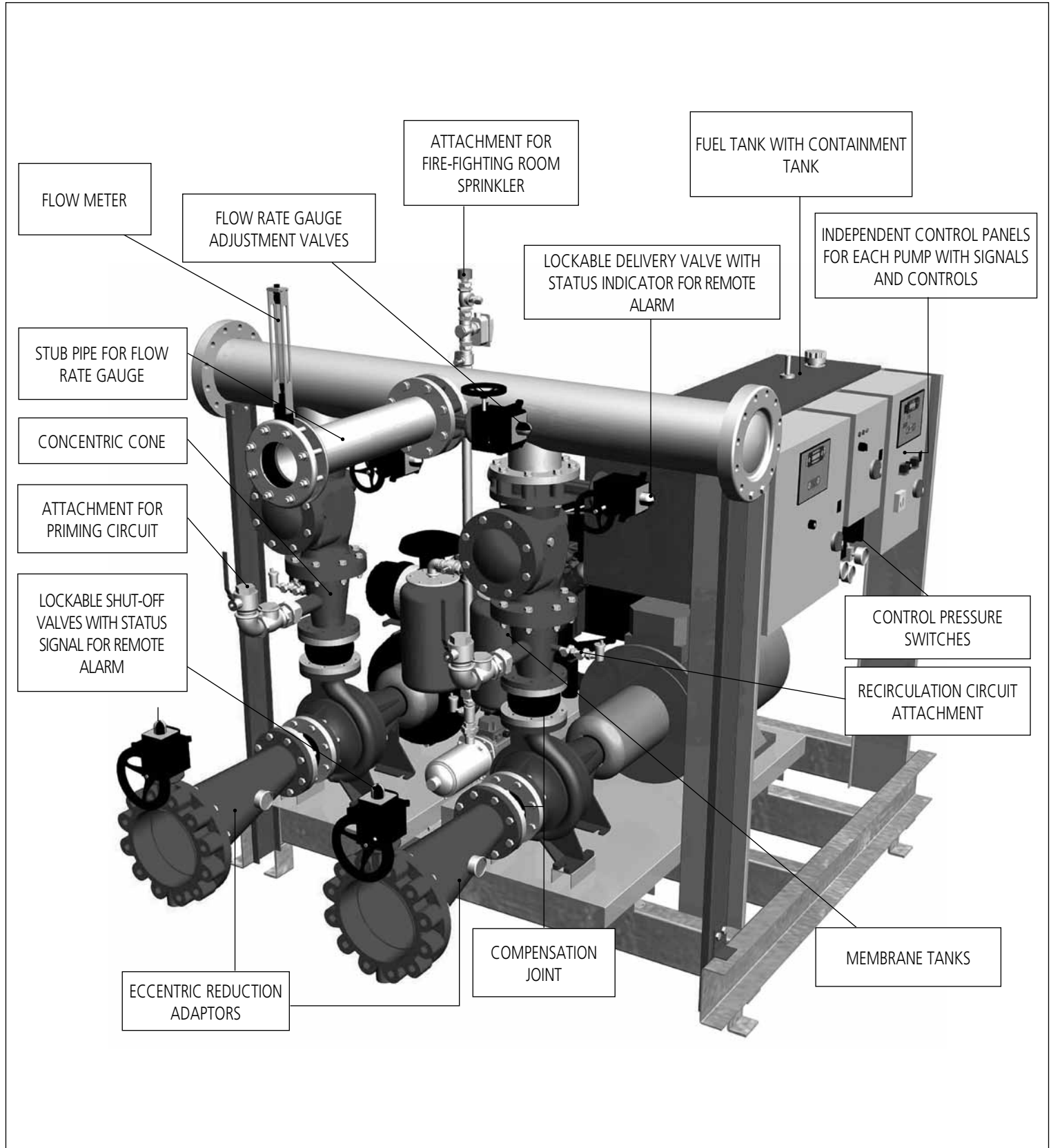

The contents of this publication should not be regarded as binding. EBARA Pompe Europe S.p.A. reserves the right to effect any modification it deems necessary, without prior notice.

## FIRE-FIGHTING UNITS

### IDENTIFICATION CODE - UNITS WITH BASE-JOINT PUMPS

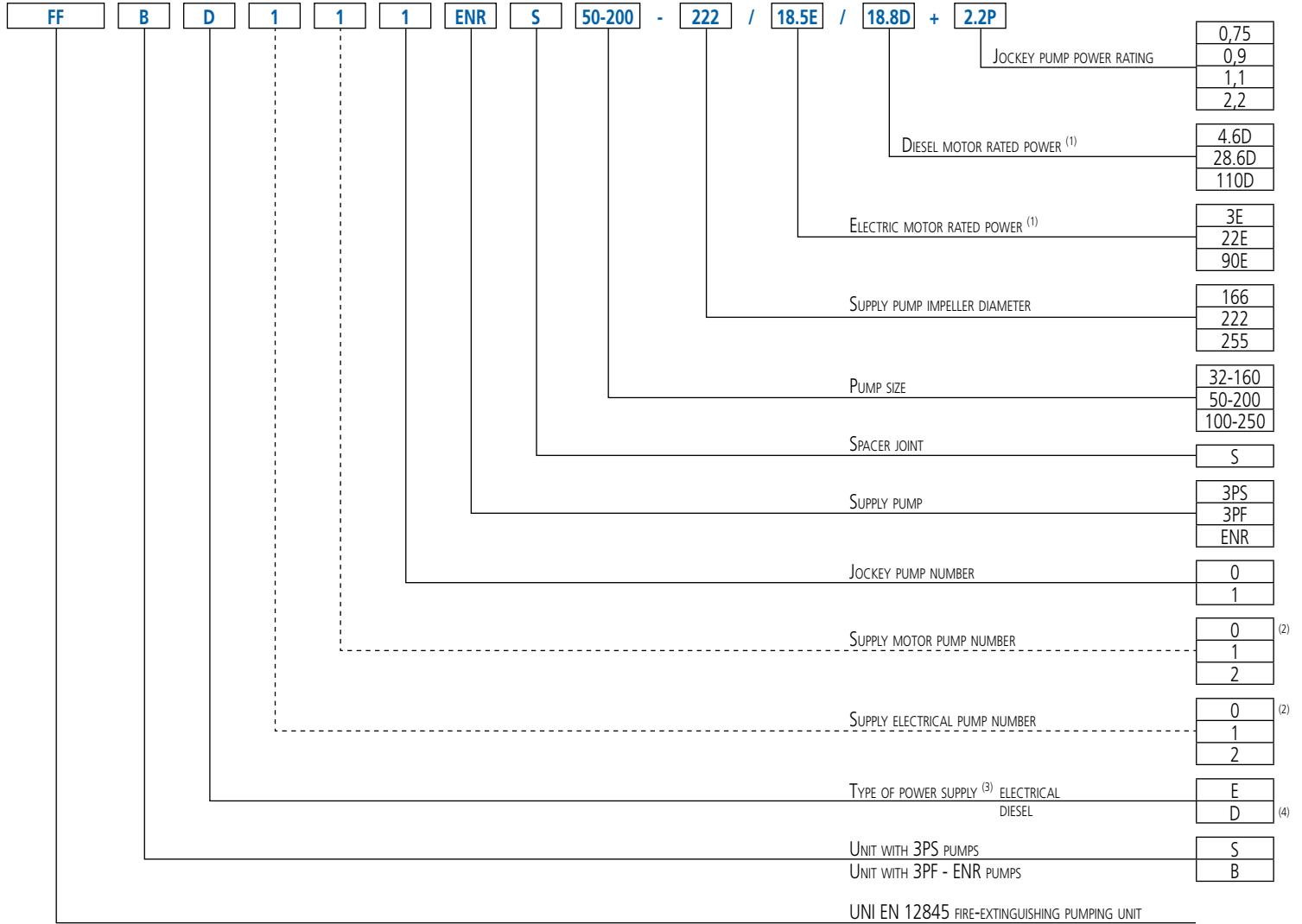

<sup>(1)</sup> Not given in the absence of the specific pump

<sup>(2)</sup> 0 quantity not indicated

<sup>(3)</sup> Not indicated for units with 3PS pumps

<sup>(4)</sup> Also in case of dual motorisation E+D



# FFS-FFB

## FIRE-FIGHTING UNITS

### IDENTIFICATION CODE - UNITS WITH ELECTRICAL SUBMERGED PUMPS

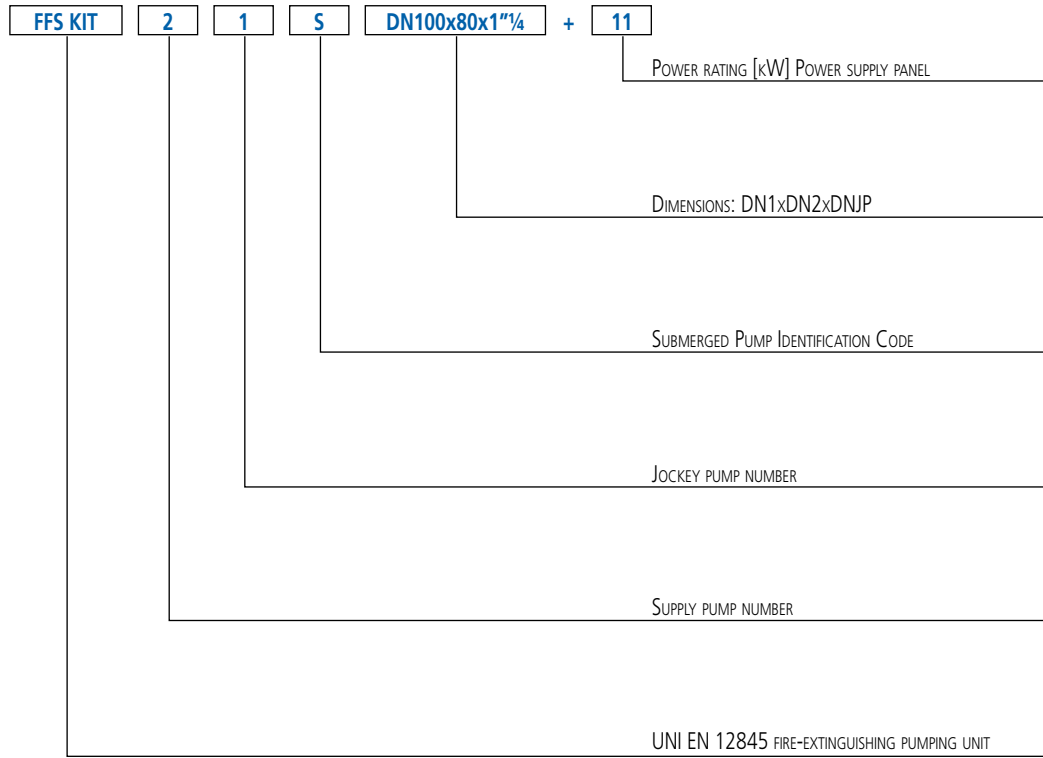

## FIRE-FIGHTING UNITS

**BASE - JOINT 32-40 (3PF - ENR) PERFORMANCE TABLE**

Series pump	Size pump	Q=Flow rate															
		l/min m³/h	100 6	150 9	200 12	250 15	300 18	333 20	360 21	370 22	400 24	450 27	500 30	590 35	660 40	700 42	710 43
		H=Head [m]															
3PF	32-160-166	35,5	34,0	32,0	30,0	27,0	25,0	-	-	-	-	-	-	-	-	-	-
3PF	32-200-186	42,0	40,0	37,5	35,1	31,0	28,0	-	-	-	-	-	-	-	-	-	-
3PF	32-200-200	53,5	52,0	49,5	46,5	43,5	40,5	38,0	-	-	-	-	-	-	-	-	-
3PF	32-200-224	69,0	67,5	65,0	62,5	58,5	55,5	53,0	52,0	49,0	44,0	-	-	-	-	-	-
ENR	32-250-245	82,5	82,0	80,0	76,5	71,0	66,0	60,5	-	-	-	-	-	-	-	-	-
ENR	32-250-255	92,3	91,5	89,5	86,0	80,5	75,5	70,0	68,0	-	-	-	-	-	-	-	-
3PF	40-160-166	-	-	38,5	37,5	36,8	36,0	35,5	35,2	34,5	33,2	31,9	29,2	26,9	25,5	-	-
3PF	40-200-183	-	-	45,5	44,5	44,0	43,0	42,5	42,0	41,0	39,5	38,0	35,1	32,5	31,0	-	-
3PF	40-200-200	-	-	57,0	56,5	55,5	55,0	54,6	54,5	53,5	52,5	51,0	48,0	45,5	44,0	-	-
3PF	40-200-224	-	-	71,0	70,5	70,2	70,0	69,5	69,0	68,5	67,5	66,0	63,0	60,5	59,0	-	-
ENR	40-250-220	-	-	65,5	65	63,5	62,5	61,5	61,0	60,0	57,5	54,5	47,0	-	-	-	-
ENR	40-250-239	-	-	79,8	79,5	78,5	78,0	77,5	77,0	76,0	74,0	71,5	65,5	59,5	-	-	-
ENR	40-250-252	-	-	91,0	90,5	90,0	89,0	88,5	88,3	87,5	86,0	83,5	78,5	73,5	70,0	69,0	-

**BASE - JOINT 50-65 (3PF - ENR) PERFORMANCE TABLE**

Series pump	Size pump	Q=Flow rate															
		l/min m³/h	400 24	450 27	500 30	590 35	660 40	700 42	800 48	1050 63	1150 69	1200 72	1320 79	1600 96	2200 132	2300 138	2400 144
		H=Head [m]															
3PF	50-160-154	31,0	30,4	29,9	28,7	27,7	27,1	25,5	21,0	19,0	18,0	-	-	-	-	-	-
3PF	50-160-166	38,5	38,0	37,5	36,3	35,4	35,0	33,5	29,0	27,0	26,0	-	-	-	-	-	-
3PF	50-200-197	-	-	53,0	52,0	50,5	50,0	48,0	42,0	38,7	37,0	-	-	-	-	-	-
3PF	50-200-212	-	-	63,0	62,0	61,5	61,0	59,0	54,0	51,0	49,5	-	-	-	-	-	-
3PF	50-200-224	-	-	70,0	69,0	68,5	68,0	66,0	61,0	58,5	57,0	-	-	-	-	-	-
ENR	50-250-222	67,0	66,5	66,0	64,5	63,0	62,0	59,5	49,5	-	-	-	-	-	-	-	-
ENR	50-250-235	76,0	75,5	75,0	74,0	73,0	72,0	69,5	61,0	56,0	-	-	-	-	-	-	-
ENR	50-250-252	90,0	89,8	89,5	88,5	87,5	87,0	85,0	77,5	73,5	71,5	65,0	-	-	-	-	-
3PF	65-200-190	-	-	-	-	-	51,0	50,0	47,5	46,0	45,5	44,0	40,0	30,0	-	-	-
3PF	65-200-201	-	-	-	-	-	58,5	57,5	55,0	53,5	53,0	51,5	47,5	38,0	36,5	-	-
3PF	65-200-208	-	-	-	-	-	62,0	61,0	58,5	57,0	56,5	55,0	51,0	41,5	40,0	-	-
3PF	65-200-212	-	-	-	-	-	65,5	65,0	62,5	61,0	59,5	59,0	55,5	46,5	45,0	-	-
ENR	65-250-226	-	-	-	-	-	-	66,5	65,5	65,0	64,9	64,0	61,0	50,5	-	-	-
ENR	65-250-237	-	-	-	-	-	-	75,5	75,0	74,5	74,0	73,0	70,0	60,5	58,5	-	-
ENR	65-250-252	-	-	-	-	-	-	89,0	88,0	87,5	87,0	86,5	83,5	74,5	72,5	70,5	-

**BASE - JOINT 80-100 (ENR) PERFORMANCE TABLE**

Series pump	Size pump	Q=Flow rate															
		l/min m³/h	1200 72	1600 96	2000 120	2300 138	2600 156	3000 180	3150 189	3300 198	3500 210	3600 216	3800 228	4400 264	4700 282	5000 300	5200 312
		H=Head [m]															
ENR	80-200-190	47,5	45,5	43,0	40,0	36,4	30,5	-	-	-	-	-	-	-	-	-	-
ENR	80-200-199	54,0	53,0	50,5	47,5	44,0	38,8	36,5	34,0	-	-	-	-	-	-	-	-
ENR	80-200-207	61,0	60,0	58,0	56,0	53,0	48,0	46,0	44,0	41,0	39,1	-	-	-	-	-	-
ENR	80-200-214	66,5	66,0	64,5	63,0	60,5	56,5	55,0	53,0	50,0	48,5	45,5	-	-	-	-	-
ENR	80-250-222	64,0	62,5	60,0	56,5	52,0	45,0	-	-	-	-	-	-	-	-	-	-
ENR	80-250-234	73,5	72,5	70,0	67,0	63,0	55,5	52,5	-	-	-	-	-	-	-	-	-
ENR	80-250-243	82,5	82,0	80,0	77,0	72,5	65,0	61,5	58,5	-	-	-	-	-	-	-	-
ENR	80-250-255	93,0	92,5	91,0	88,5	85,0	78,5	75,5	72,0	67,5	-	-	-	-	-	-	-
ENR	100-200-182	-	39,5	38,5	37,5	36,0	33,5	32,5	31,3	29,7	28,9	27,2	21,8	-	-	-	-
ENR	100-200-190	-	44,5	43,5	43,0	41,5	40,0	38,9	37,9	36,5	35,7	34,0	28,5	25,5	-	-	-
ENR	100-200-194	-	47,0	46,5	45,5	45,0	43,0	42,0	41,5	39,9	39,2	37,6	32,5	29,5	-	-	-
ENR	100-200-197	-	49,5	49,0	48,5	47,5	46,0	45,0	44,0	43,0	42,0	40,5	35,5	33,0	30,0	-	-
ENR	100-200-201	-	52,0	51,5	51,0	50,0	48,5	48,0	47,0	46,0	45,5	44,0	39,3	36,7	33,5	-	-
ENR	100-200-209	-	56,5	56,0	55,5	55,0	53,5	53,0	52,5	51,0	50,5	49,5	45,0	42,5	39,8	38,0	-
ENR	100-200-213	-	59,0	58,5	58,0	57,5	56,0	55,5	55,0	54,0	53,0	52,0	47,5	45,5	43,0	41,0	-
ENR	100-250-221	-	62,0	61,0	60,0	59,0	56,5	56,0	55,0	53,5	52,5	50,5	44,0	-	-	-	-
ENR	100-250-225	-	65,5	64,5	63,5	62,5	60,5	59,5	58,5	57,0	56,0	54,5	48,0	44,0	-	-	-
ENR	100-250-232	-	71,0	70,5	69,5	68,5	66,5	65,5	64,5	63,0	62,0	60,5	54,0	50,0	-	-	-
ENR	100-250-242	-	80,0	79,0	78,5	77,5	76,0	75,5	74,5	73,0	72,0	70,5	64,0	60,0	56,0	-	-
ENR	100-250-248	-	85,0	84,5	84,0	83,0	81,5	81,0	80,5	79,0	78,5	77,0	71,0	67,5	64,0	61,0	-
ENR	100-250-255	-	91,0	90,5	90,0	89,5	88,5	88,0	87,0	86,0	85,5	84,0	78,0	75,0	71,5	68,5	-

## FIRE-FIGHTING UNITS

**AGA SUR (JOCKEY) PERFORMANCE TABLE**

Model	P <sub>2</sub>		Q=Flow rate							
	[HP]	[kW]	l/min m <sup>3</sup> /h	10 0,6	20 1,2	30 1,8	40 2,4	50 3	60 3,6	70 4,2
			H=Head [m]							
AGA 300T SUR	3	2,2	73,5	68,0	63,5	58,8	54,5	50,9	47,3	44,0

**PERFORMANCE TABLE FOR COMPACT (JOCKEY) PUMP**

Model	P <sub>2</sub>		Q=Flow rate					
	[HP]	[kW]	l/min m <sup>3</sup> /h	20 1,2	30 1,8	40 2,4	50 3	60 3,6
			H=Head [m]					
COMPACT A/10	1	0,75	56,5	53,0	48,5	43,5	37,1	20,0
COMPACT A/12	1,2	0,9	67,5	63,5	58,5	52,5	45,0	24,0
COMPACT A/15	1,5	1,1	79,0	74,5	69,0	62,5	54,0	28,0

**PERFORMANCE TABLE FOR MATRIX (JOCKEY) PUMP**

Model	P <sub>2</sub>		Q=Flow rate					
	[HP]	[kW]	l/min m <sup>3</sup> /h	30 1,8	45 2,7	60 3,6	80 4,8	100 6
			H=Head [m]					
MATRIX 5-9T/2.2	3	2,2	97,0	92,0	87,0	78,0	66,0	39,6

PERFORMANCE CURVES for series 3PS 32-160 (impeller diameter - 166 mm) in accordance with ISO 9906 Annex A

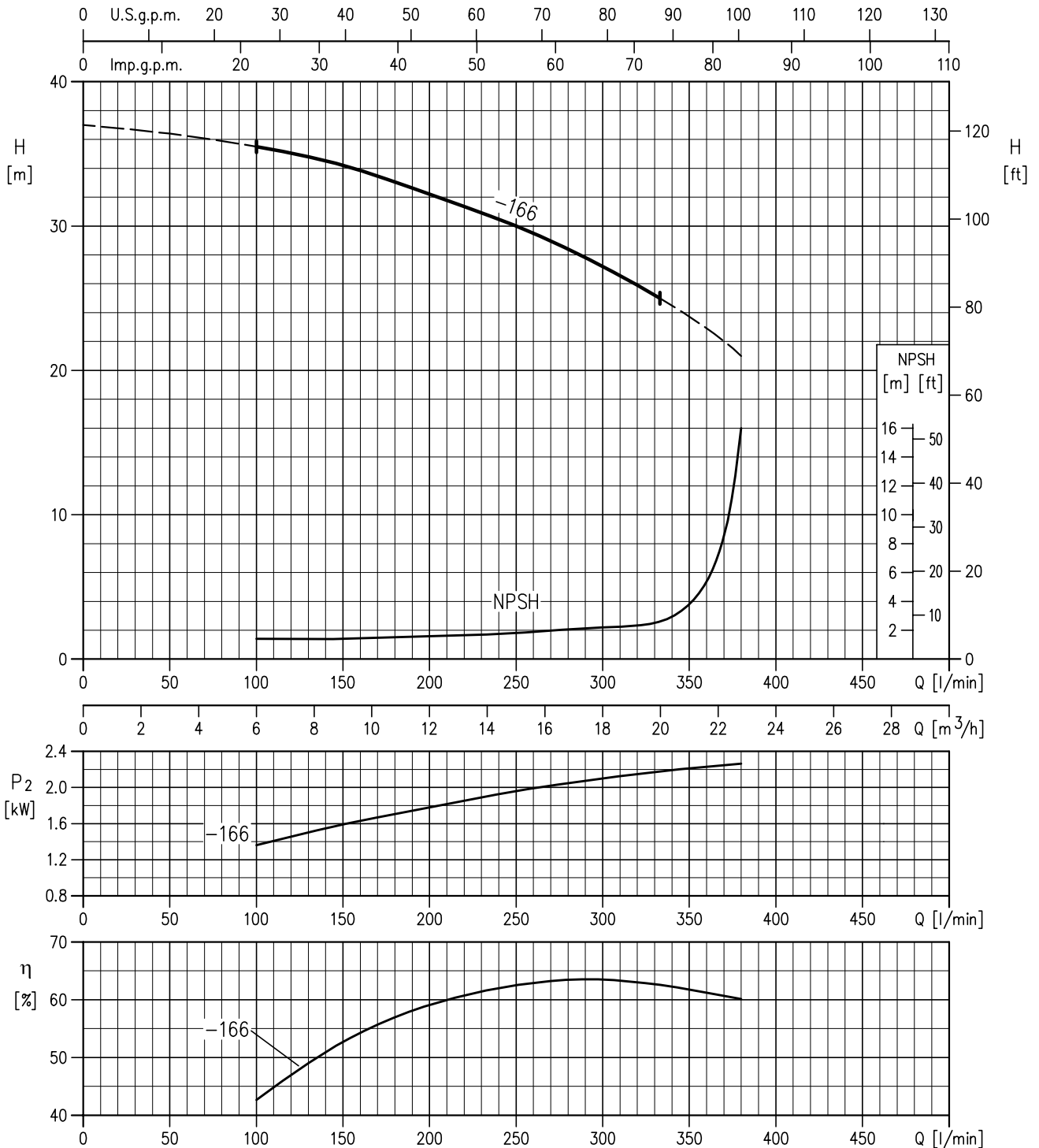

The contents of the publication should not be regarded as binding. EBARA Pumps Europe S.p.A. reserves the right to effect any modification it deems necessary, without prior notice.

PERFORMANCE CURVES for series 3PS 32-200 (impeller diameter - from 186 to 224 mm) in accordance with ISO 9906 Annex A

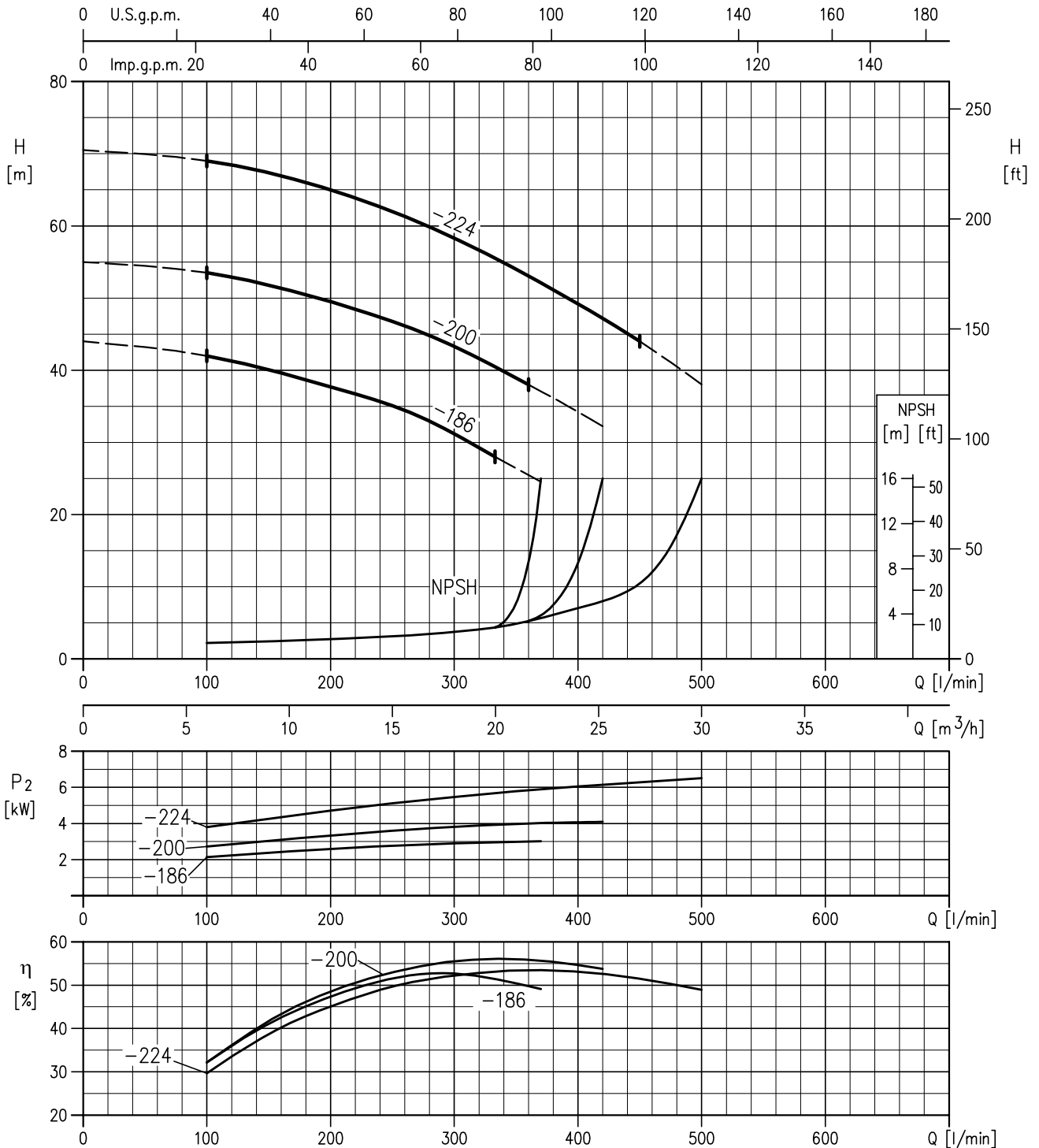

The contents of the publication should not be regarded as binding. EBARA Pompa Europe S.p.A. reserves the right to effect any modification it deems necessary, without prior notice.

PERFORMANCE CURVES for series ENR 32-250 (impeller diameter - from 245 to 255 mm) in accordance with ISO 9906 Annex A

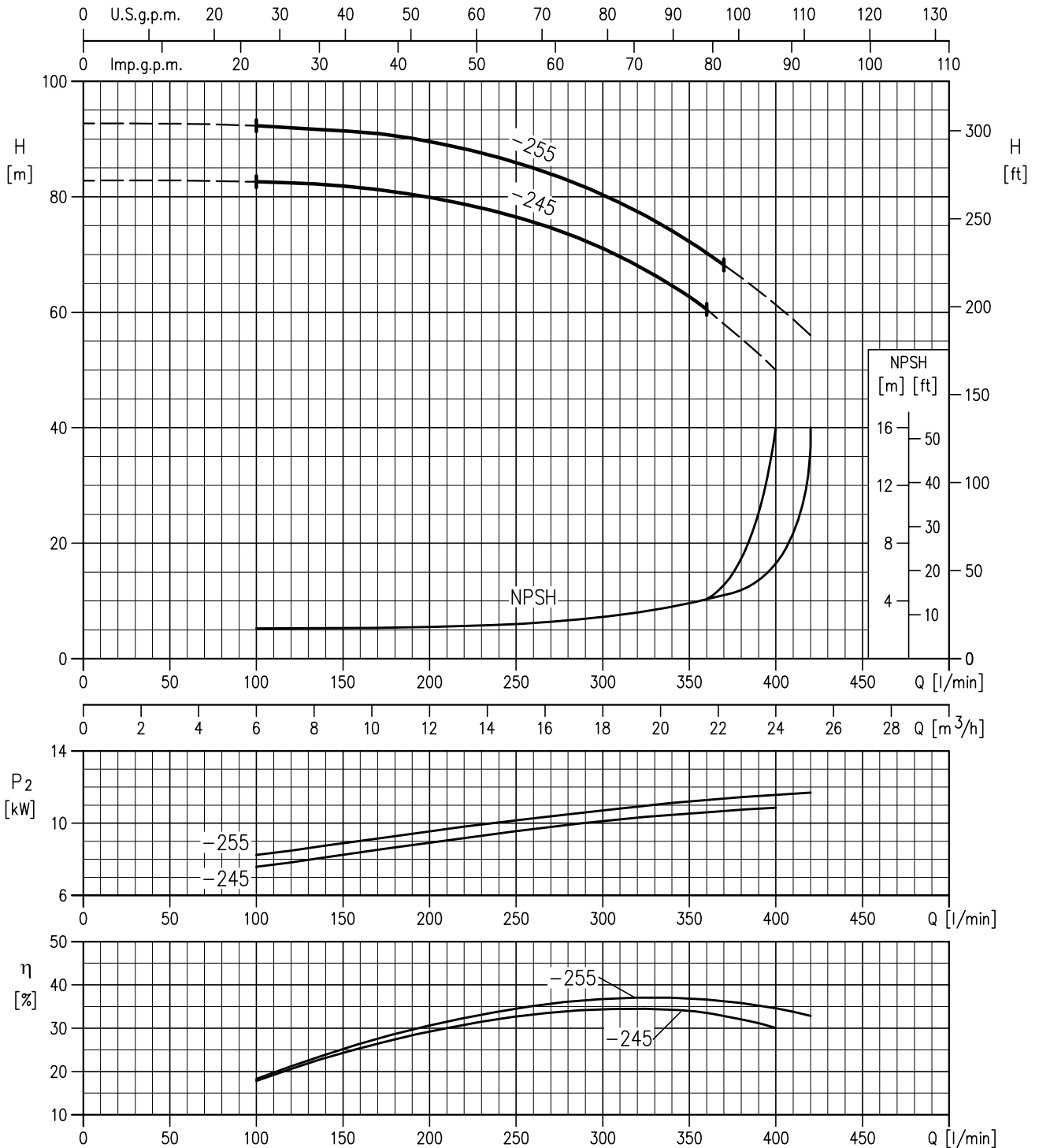

The contents of this publication should not be regarded as binding. EBARA Pumps Europe S.p.A. reserves the right to effect any modification it deems necessary, without prior notice.

PERFORMANCE CURVES for series 3PS 40-160 (impeller diameter - 166 mm) in accordance with ISO 9906 Annex A

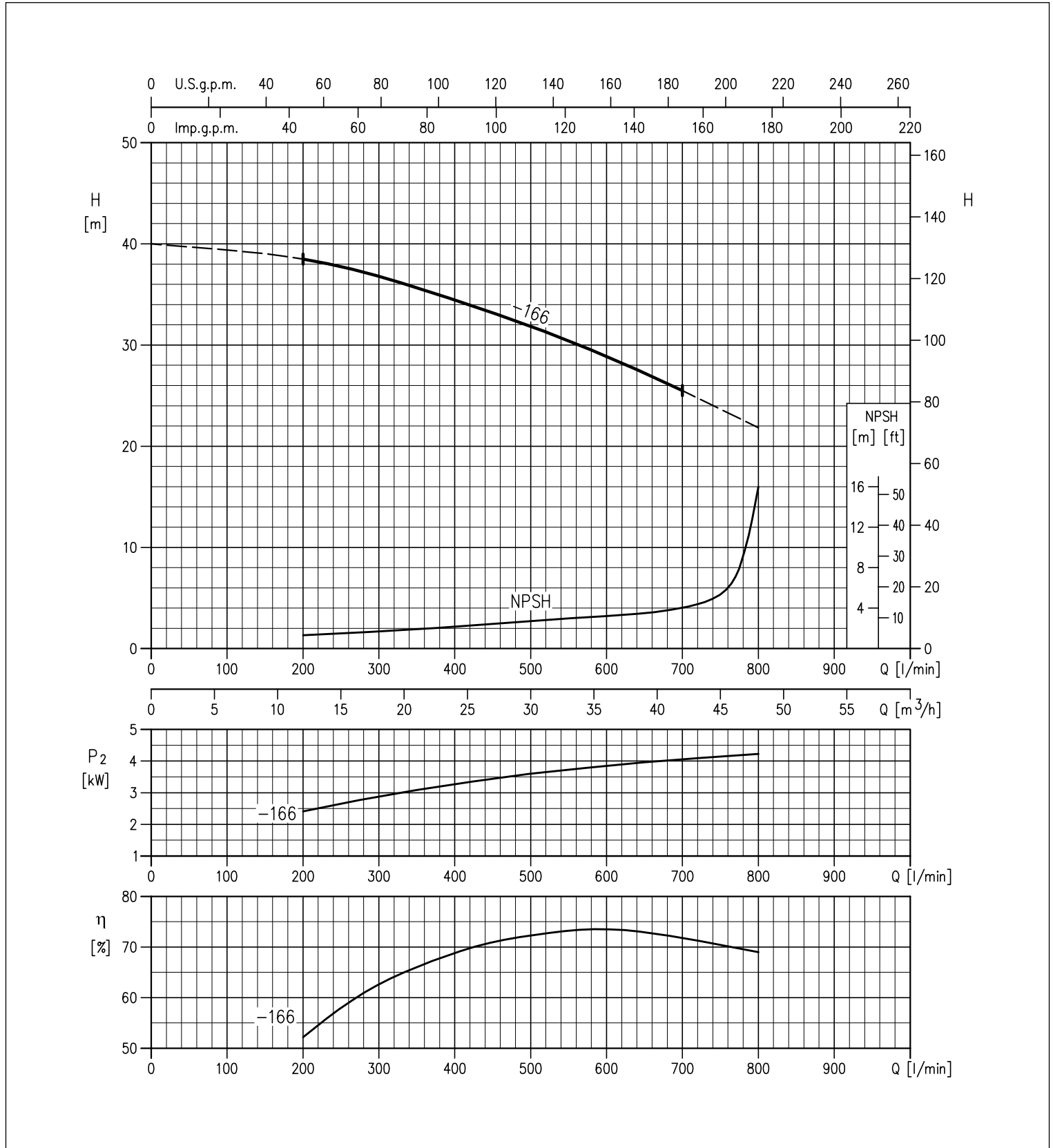

PERFORMANCE CURVES for series 3PS 40-200 (impeller diameter - from 183 to 224 mm) in accordance with ISO 9906 Annex A

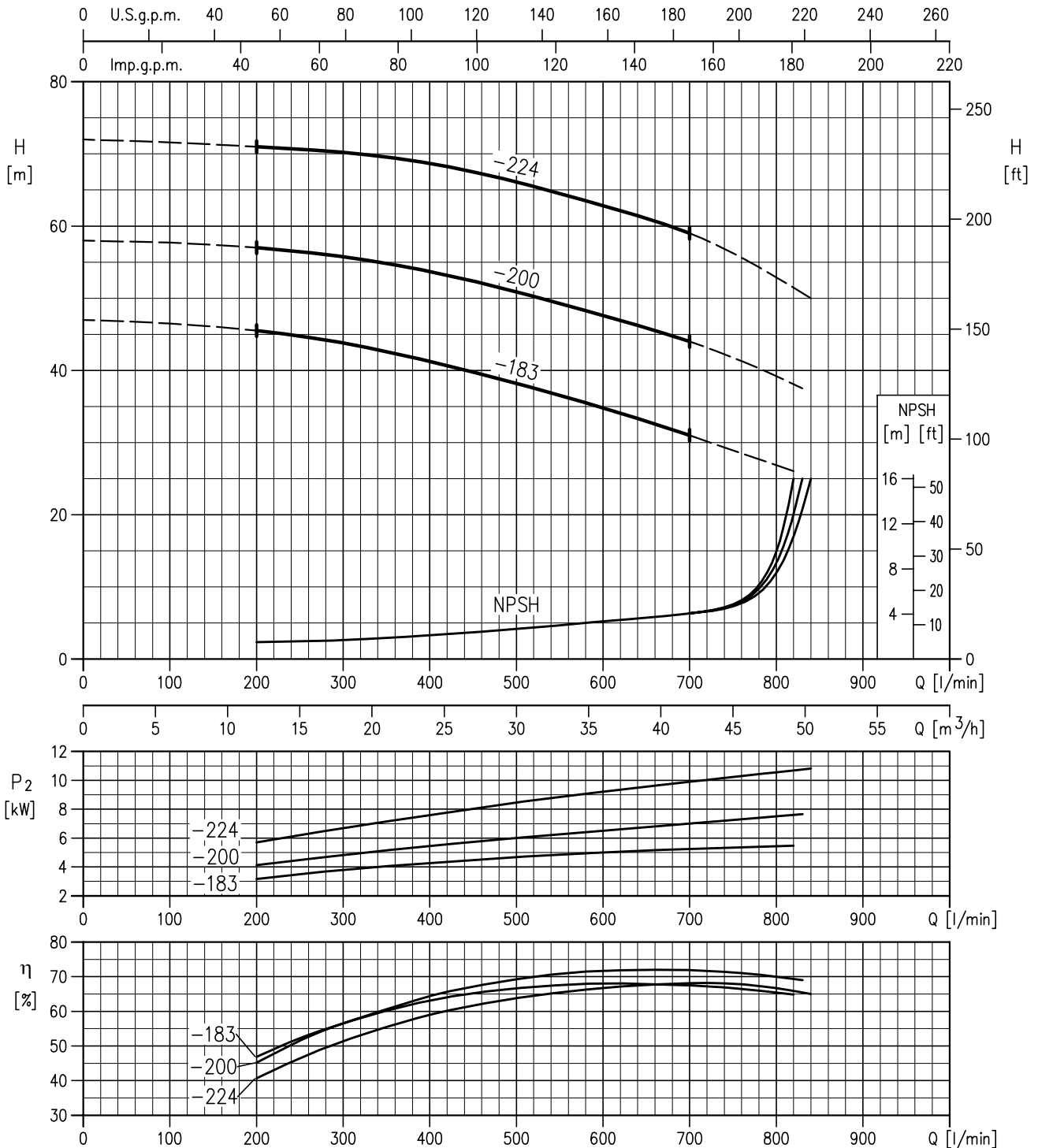

The contents of the publication should not be regarded as binding. EBARA Pumps Europe S.p.A. reserves the right to effect any modification it deems necessary, without prior notice.

PERFORMANCE CURVES for series ENR 40-250 (impeller diameter - from 220 to 252 mm) in accordance with ISO 9906 Annex A

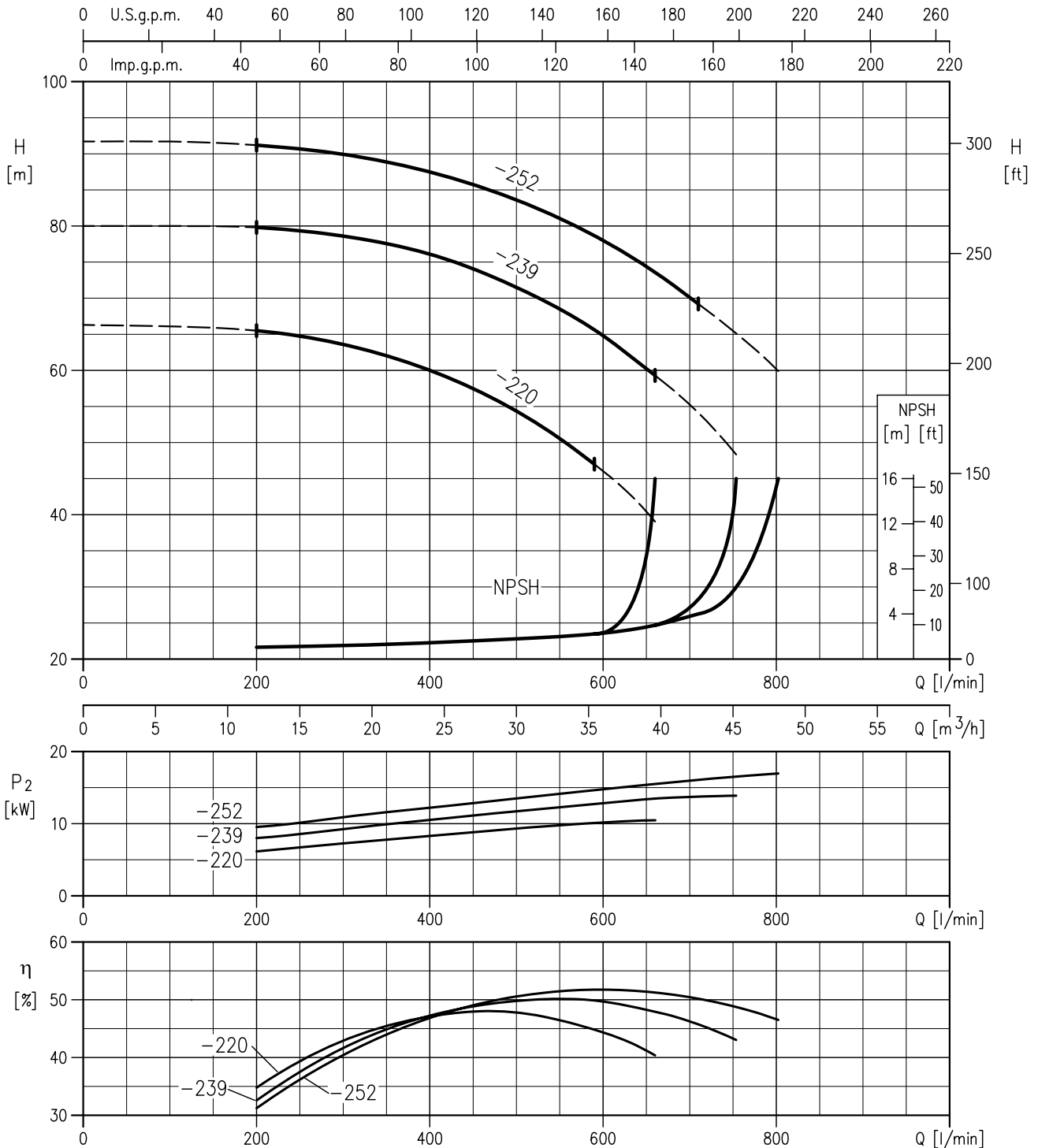

The contents of the publication should not be regarded as binding. EBARA Pompa Europe S.p.A. reserves the right to effect any modification deemed necessary, without prior notice.



# FFS-FFB

## FIRE-FIGHTING UNITS

PERFORMANCE CURVES for series 3PS 50-160 (impeller diameter - from 154 to 166 mm) in accordance with ISO 9906 Annex A

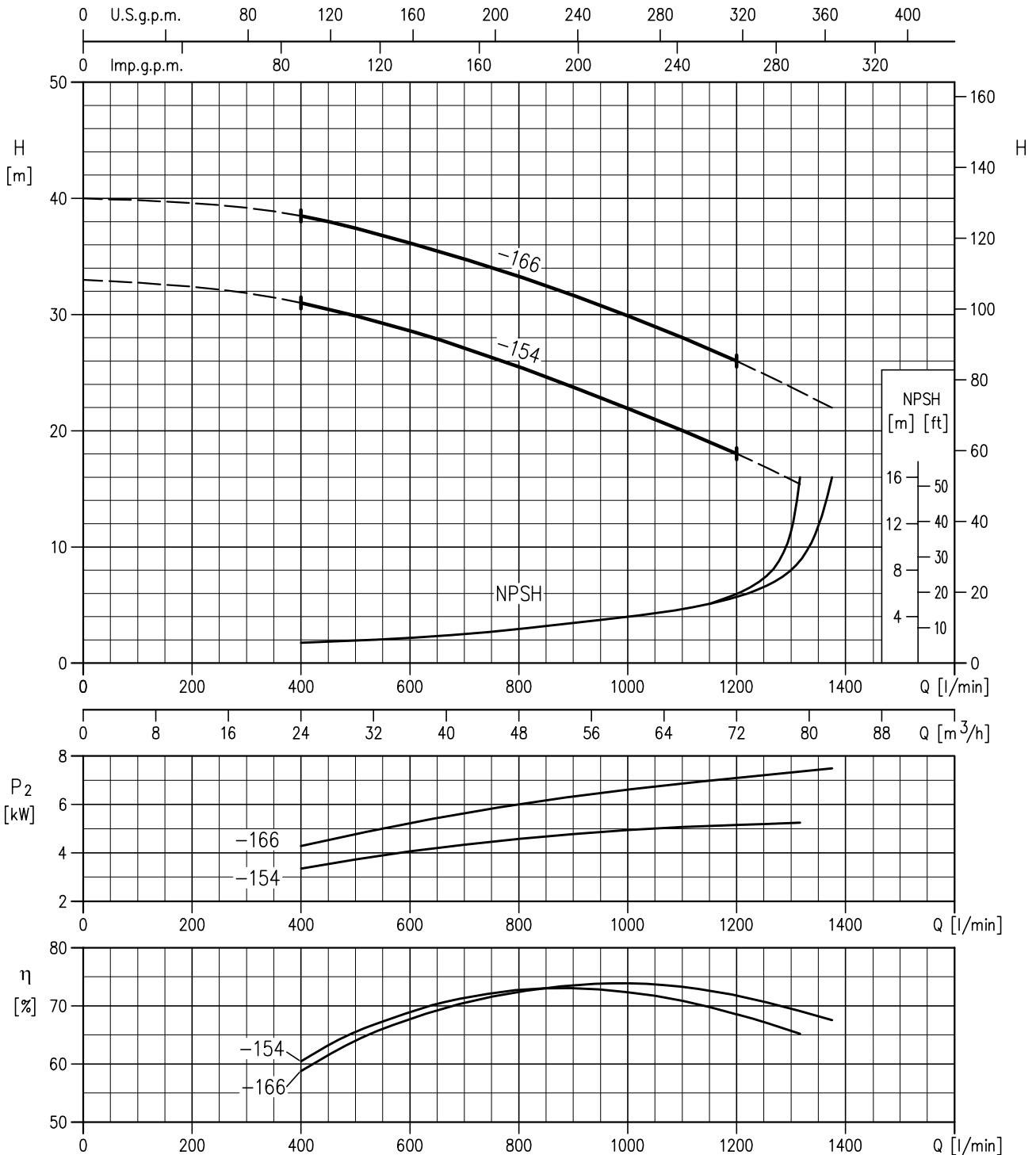

The contents of the publication should not be regarded as binding. EBARA Pumps Europe S.p.A. reserves the right to effect any modification it deems necessary, without prior notice.

PERFORMANCE CURVES for series 3PS 50-200 (impeller diameter - from 197 to 224 mm) in accordance with ISO 9906 Annex A

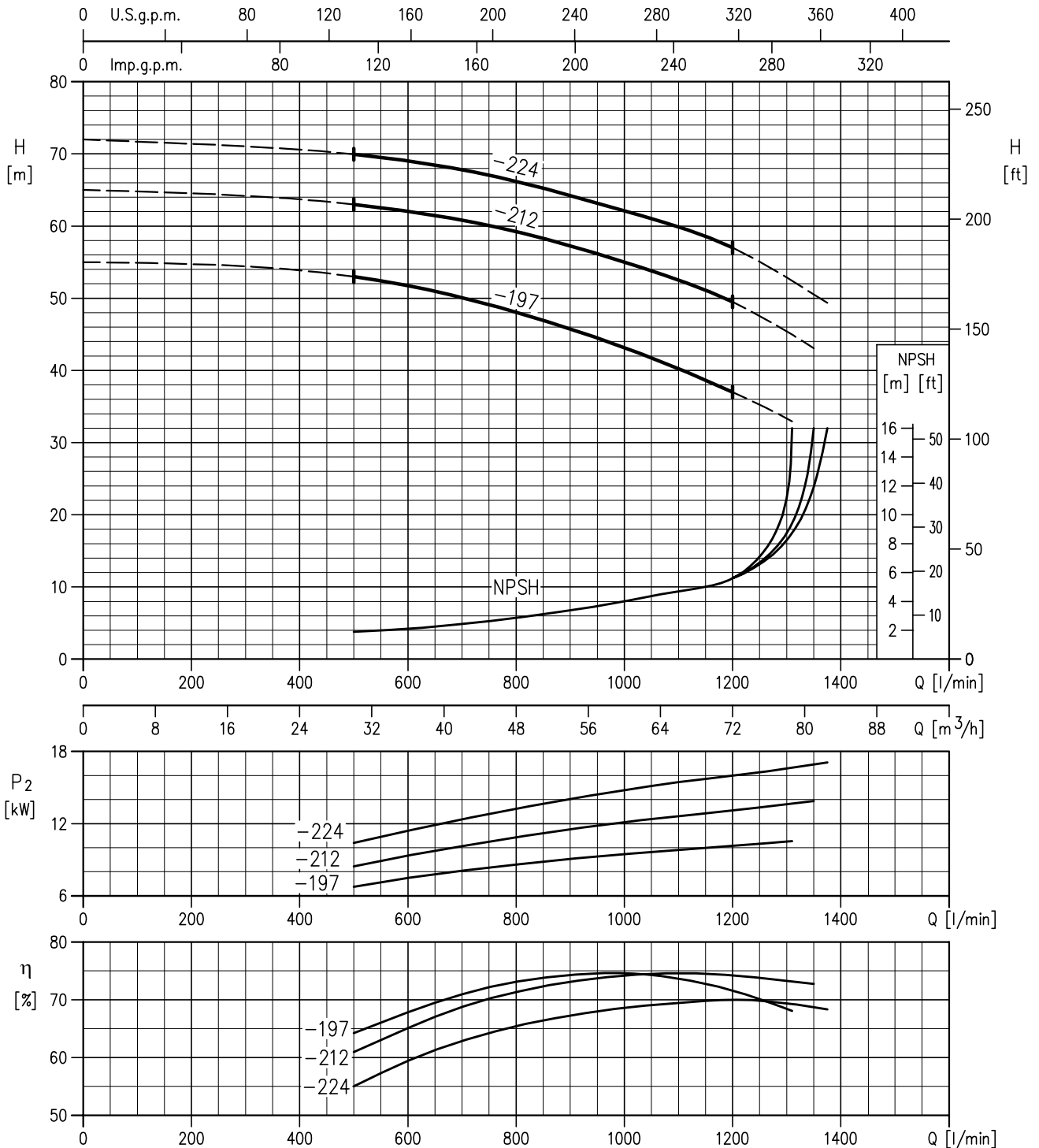

The contents of the publication should not be regarded as binding. EBARA Pompa Europe S.p.A. reserves the right to effect any modification it deems necessary, without prior notice.

PERFORMANCE CURVES for series ENR 50-250 (impeller diameter - from 222 to 252 mm) in accordance with ISO 9906 Annex A

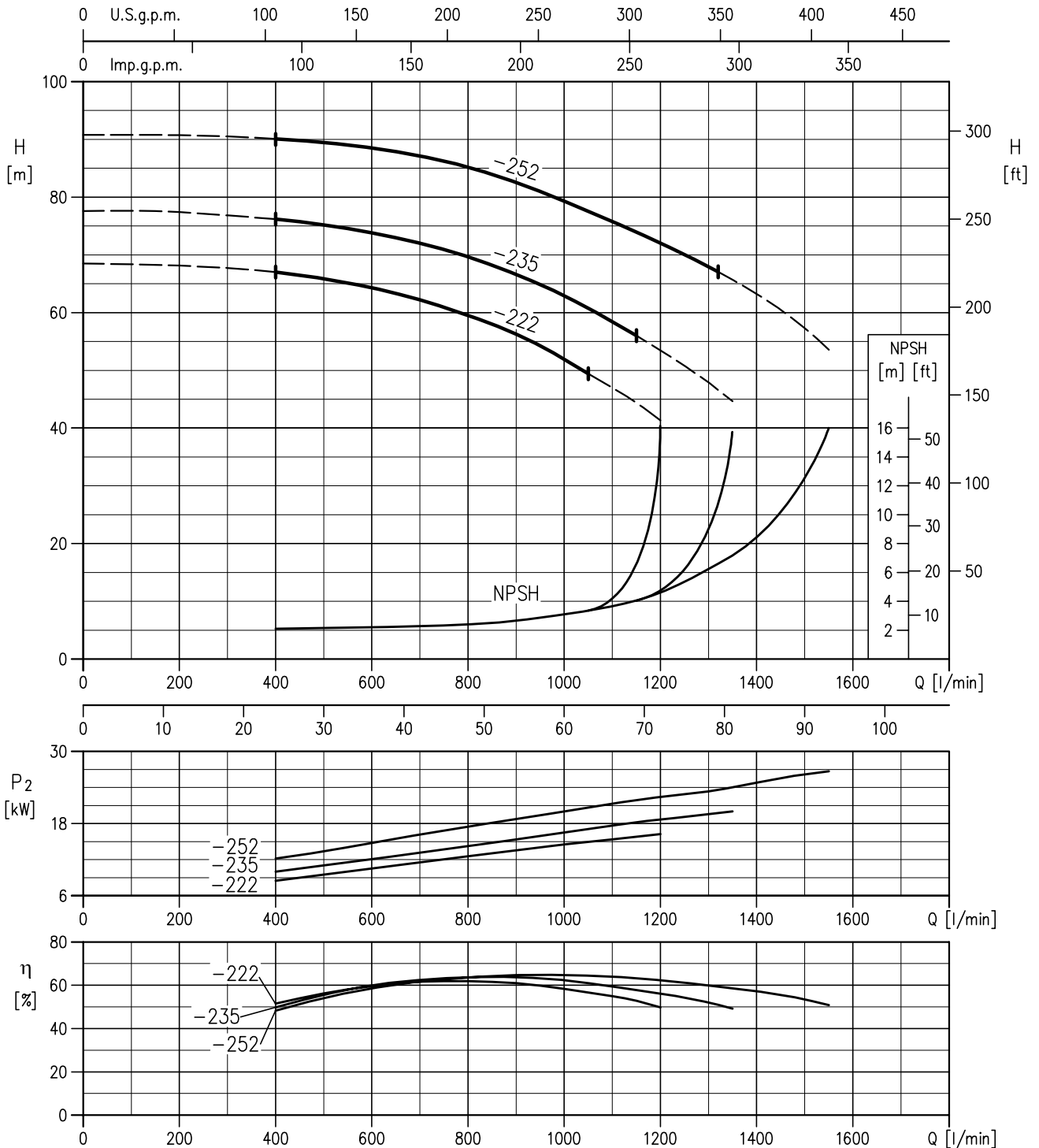

The contents of this publication should not be regarded as binding. EBARA Pumps Europe S.p.A. reserves the right to amend any modification it deems necessary, without prior notice.



# FFS-FFB

## FIRE-FIGHTING UNITS

PERFORMANCE CURVES for series 3PS 65-200 (impeller diameter - from 190 to 212 mm) in accordance with ISO 9906 Annex A

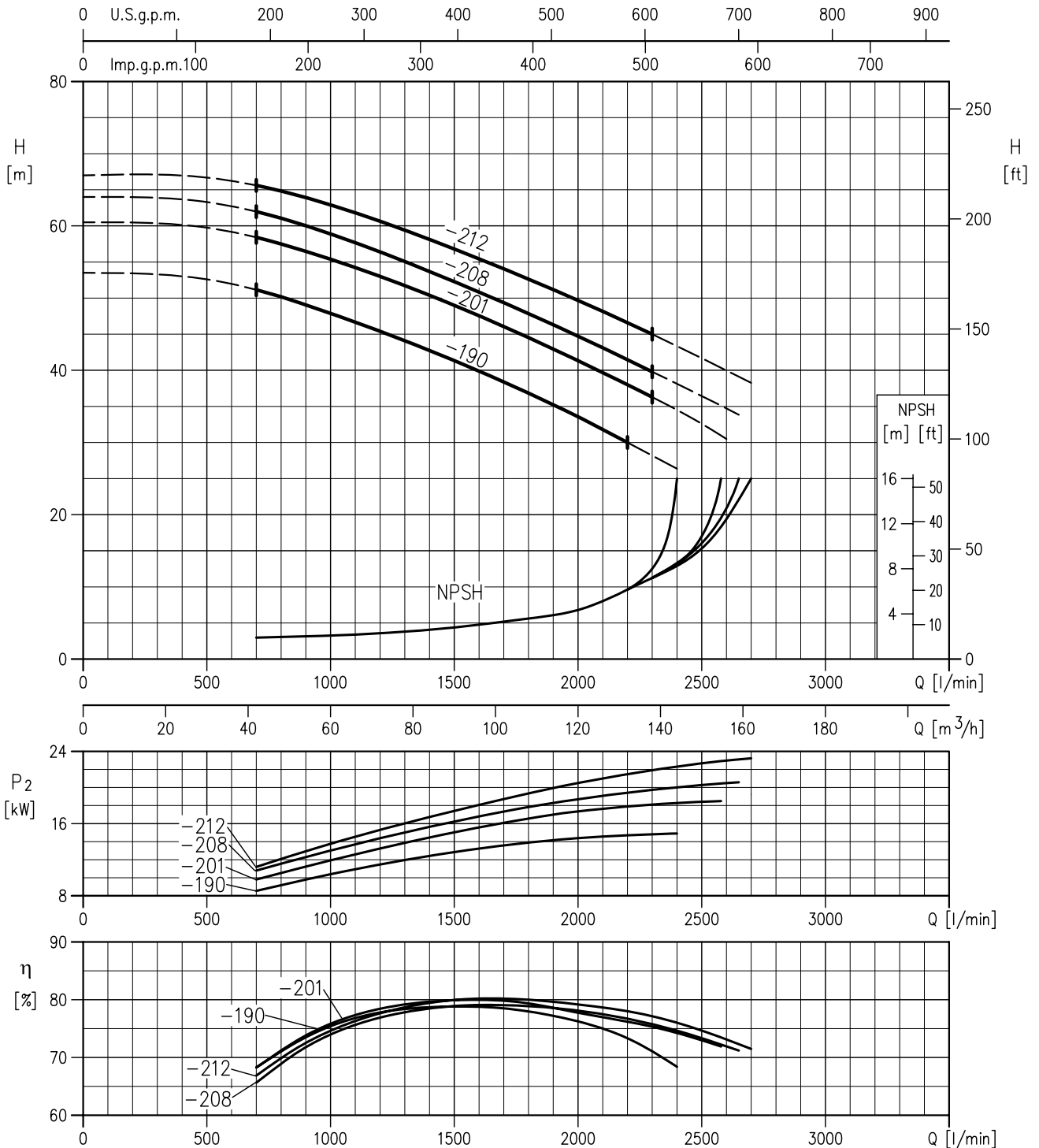

The contents of the publication should not be regarded as binding. EBARA Pompa Europe S.p.A. reserves the right to effect any modification it deems necessary, without prior notice.

PERFORMANCE CURVES for series ENR 65-250 (impeller diameter - from 226 to 252 mm) in accordance with ISO 9906 Annex A

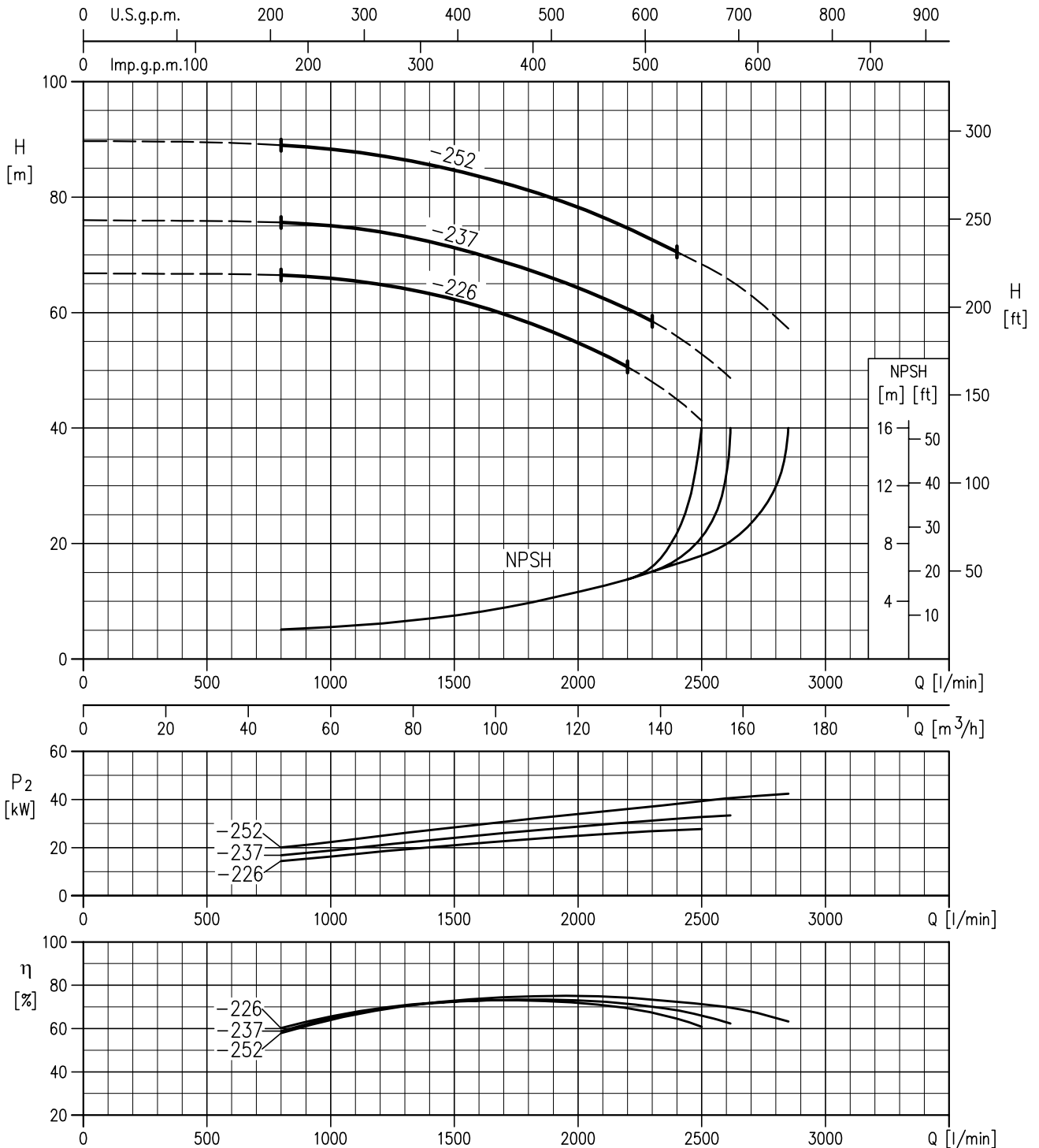

The contents of the publication should not be regarded as binding. EBARA Pumps Europe S.p.A. reserves the right to effect any modification it deems necessary, without prior notice.

PERFORMANCE CURVES for series ENR 80-200 (impeller diameter - from 190 to 214 mm) in accordance with ISO 9906 Annex A

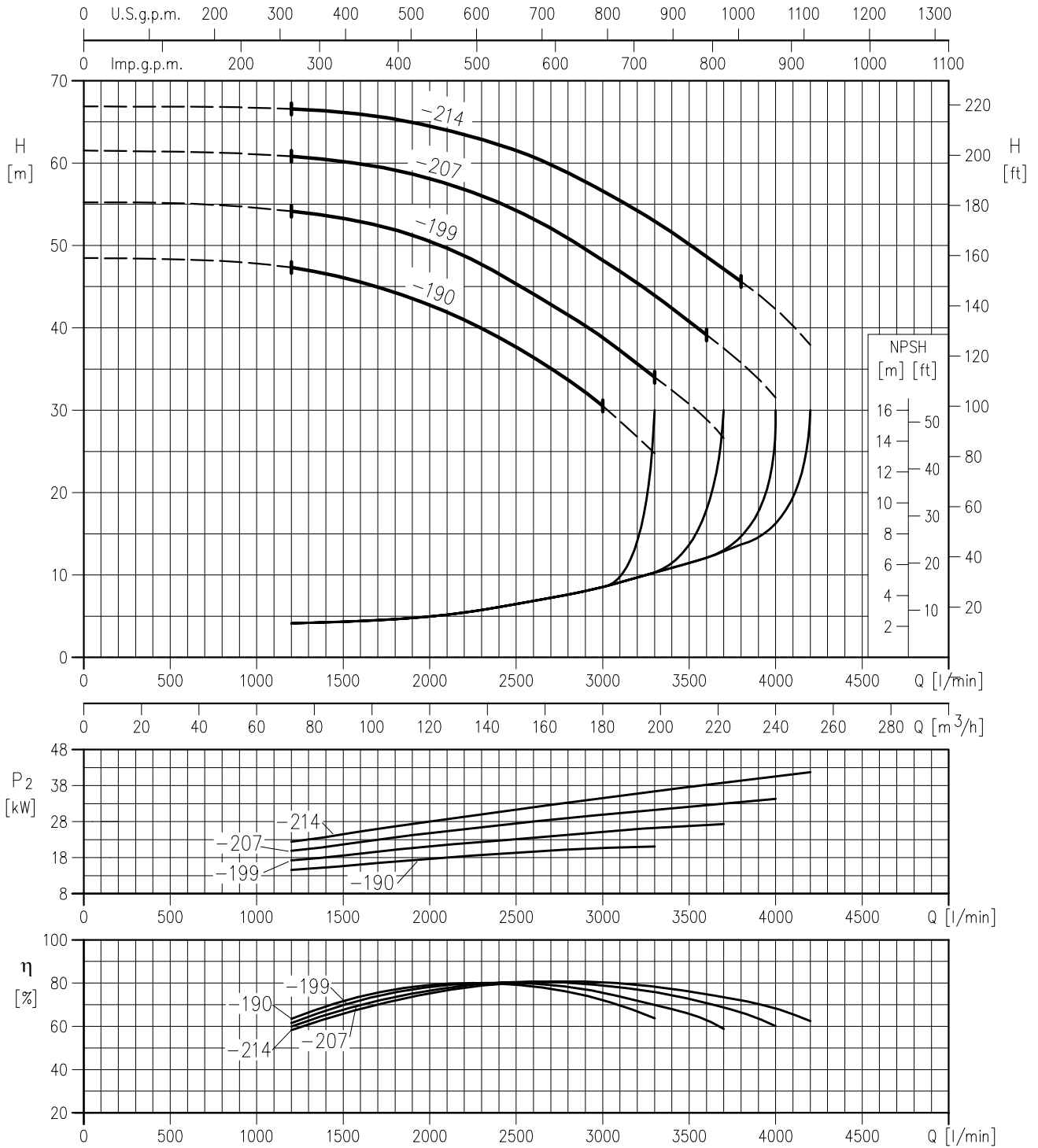

The contents of the publication should not be regarded as binding. EBARA Pumps Europe S.p.A. reserves the right to effect any modification deemed necessary, without prior notice.

PERFORMANCE CURVES for series ENR 80-250 (impeller diameter - from 222 to 255 mm) in accordance with ISO 9906 Annex A

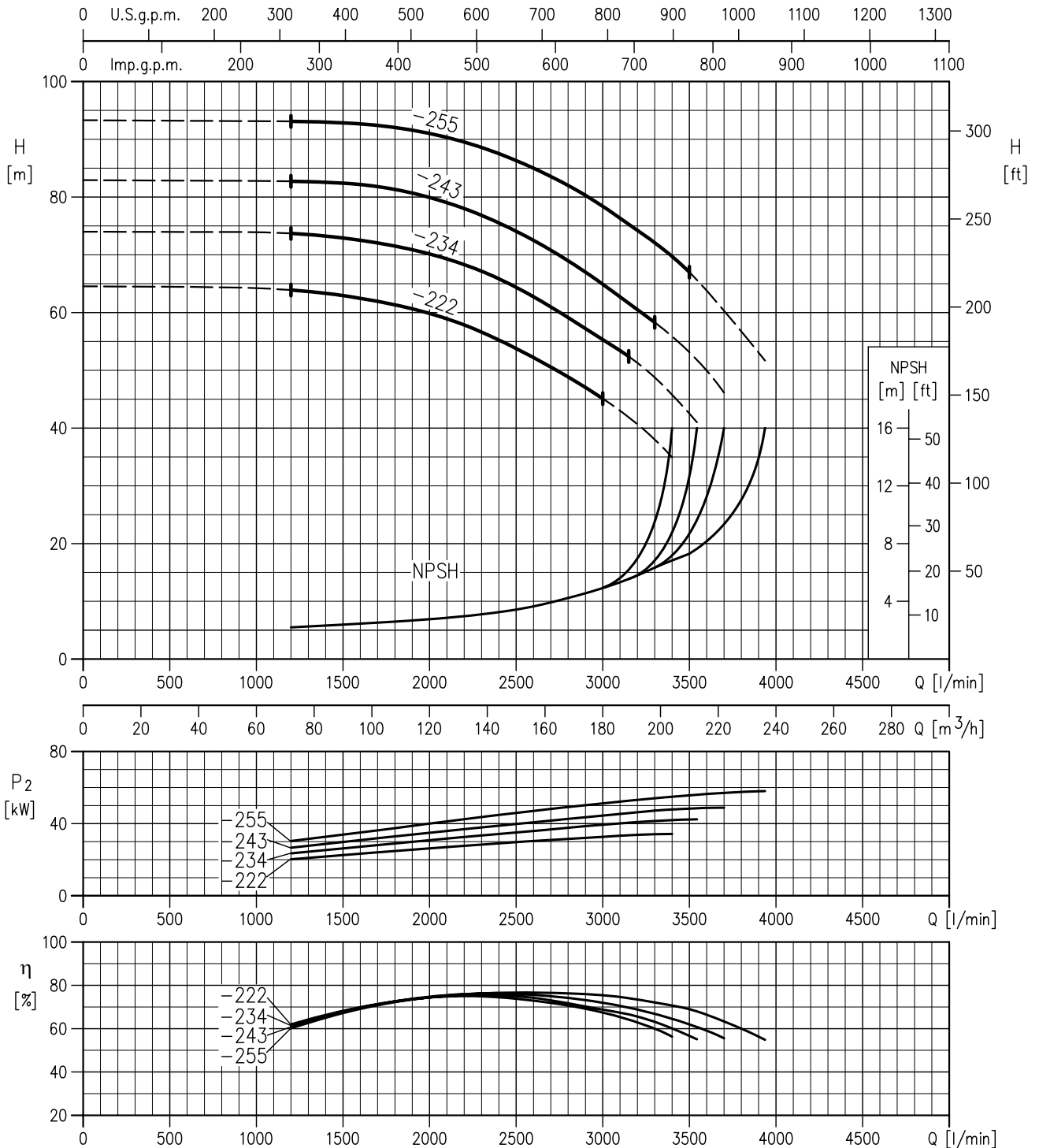

The contents of the publication should not be regarded as binding. EBARA Pumps Europe S.p.A. reserves the right to effect any modification it deems necessary, without prior notice.



# FFS-FFB

## FIRE-FIGHTING UNITS

PERFORMANCE CURVES for series ENR 100-200 (1/2) (impeller diameter - from 182 to 194 mm) in accordance with ISO 9906 Annex A

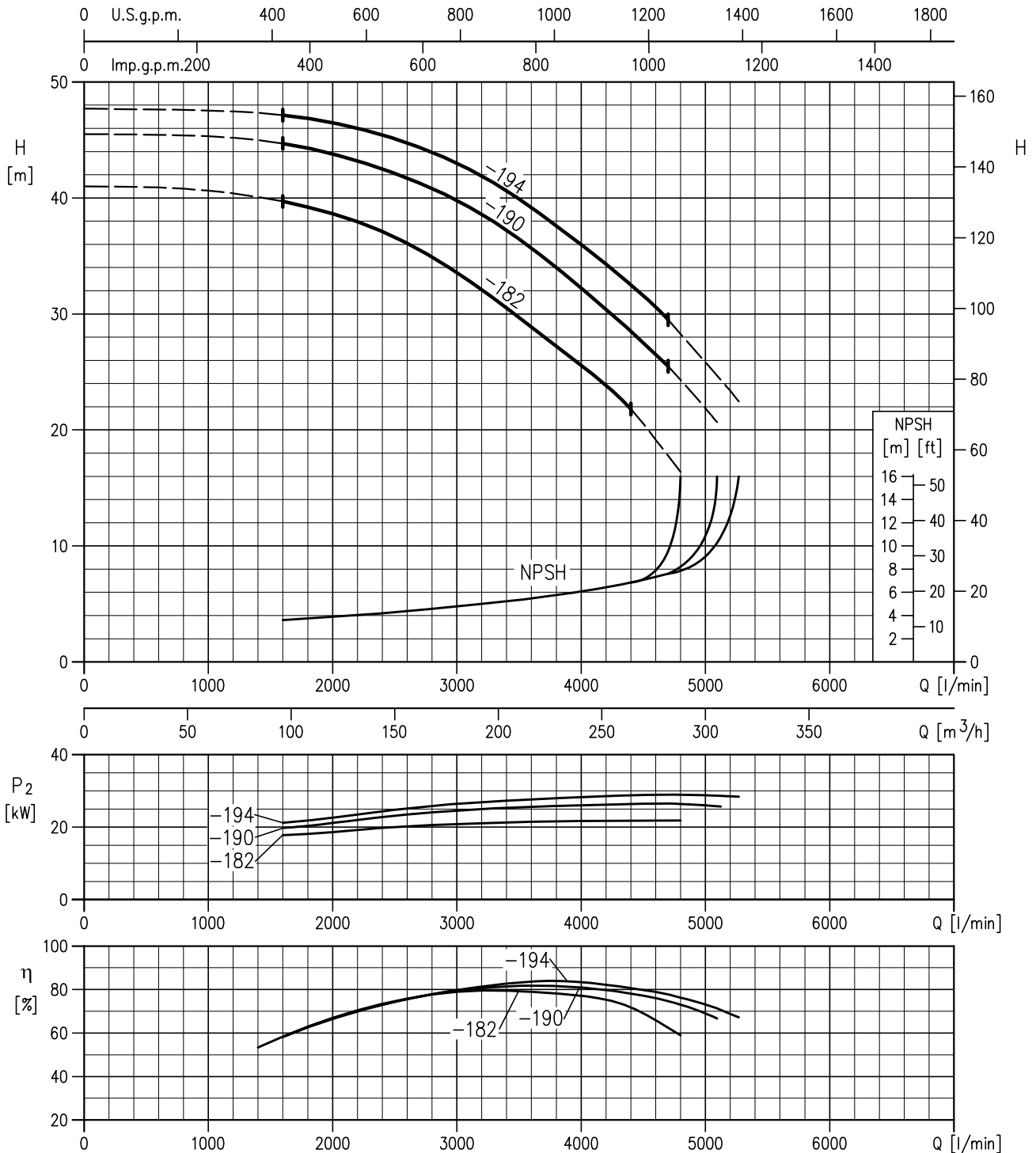

The contents of the publication should not be regarded as binding. EBARA Pompe Europe S.p.A. reserves the right to effect any modification it deems necessary, without prior notice.



# FFS-FFB

## FIRE-FIGHTING UNITS

PERFORMANCE CURVES for series ENR 100-200 (2/2) (impeller diameter - from 197 to 213 mm) in accordance with ISO 9906 Annex A

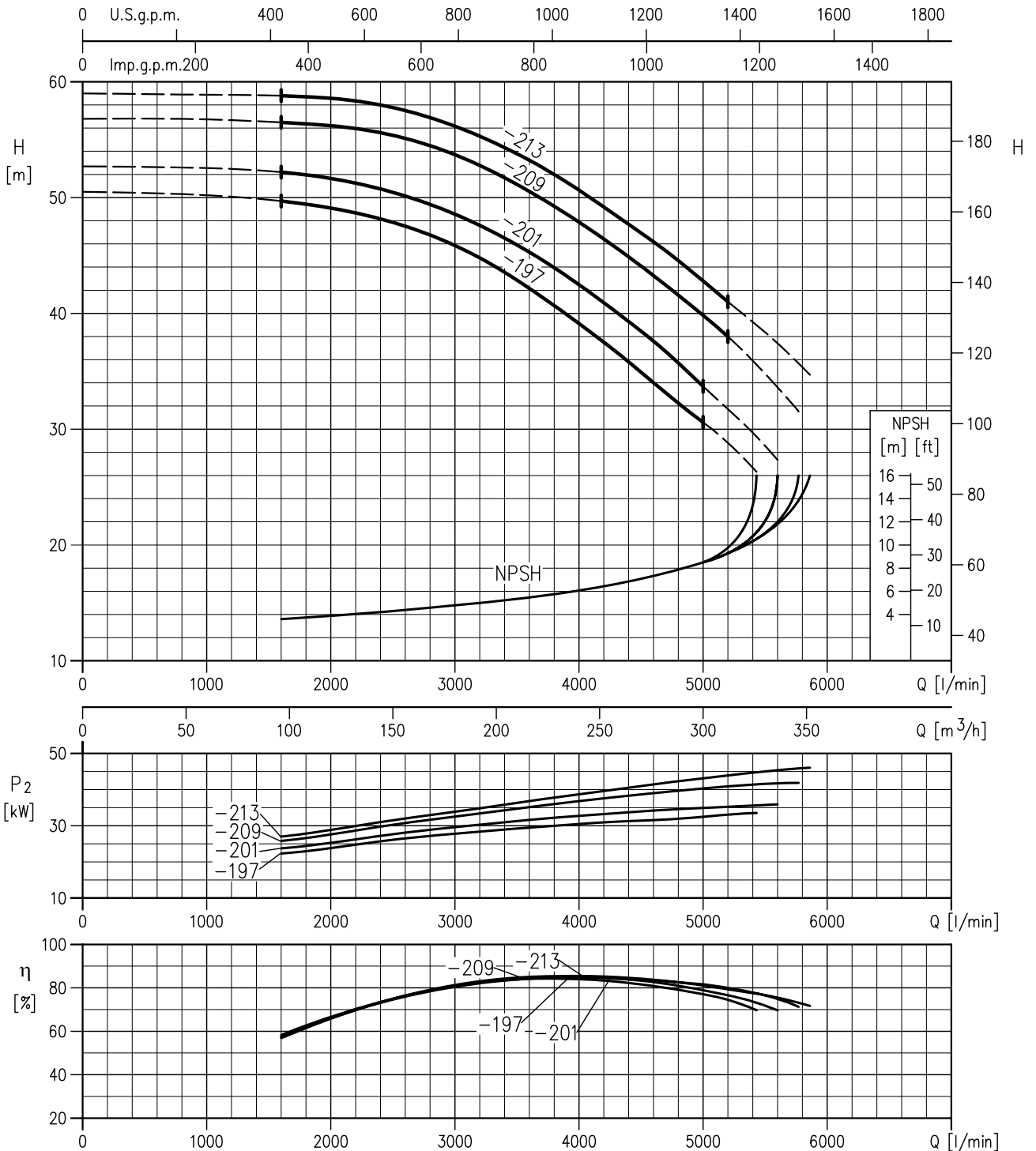

The contents of the publication should not be regarded as binding. EBARA Pumps Europe S.p.A. reserves the right to effect any modification it deems necessary, without prior notice.



# FFS-FFB

## FIRE-FIGHTING UNITS

PERFORMANCE CURVES for series ENR 100-250 (1/2) (impeller diameter - from 221 to 232 mm) in accordance with ISO 9906 Annex A

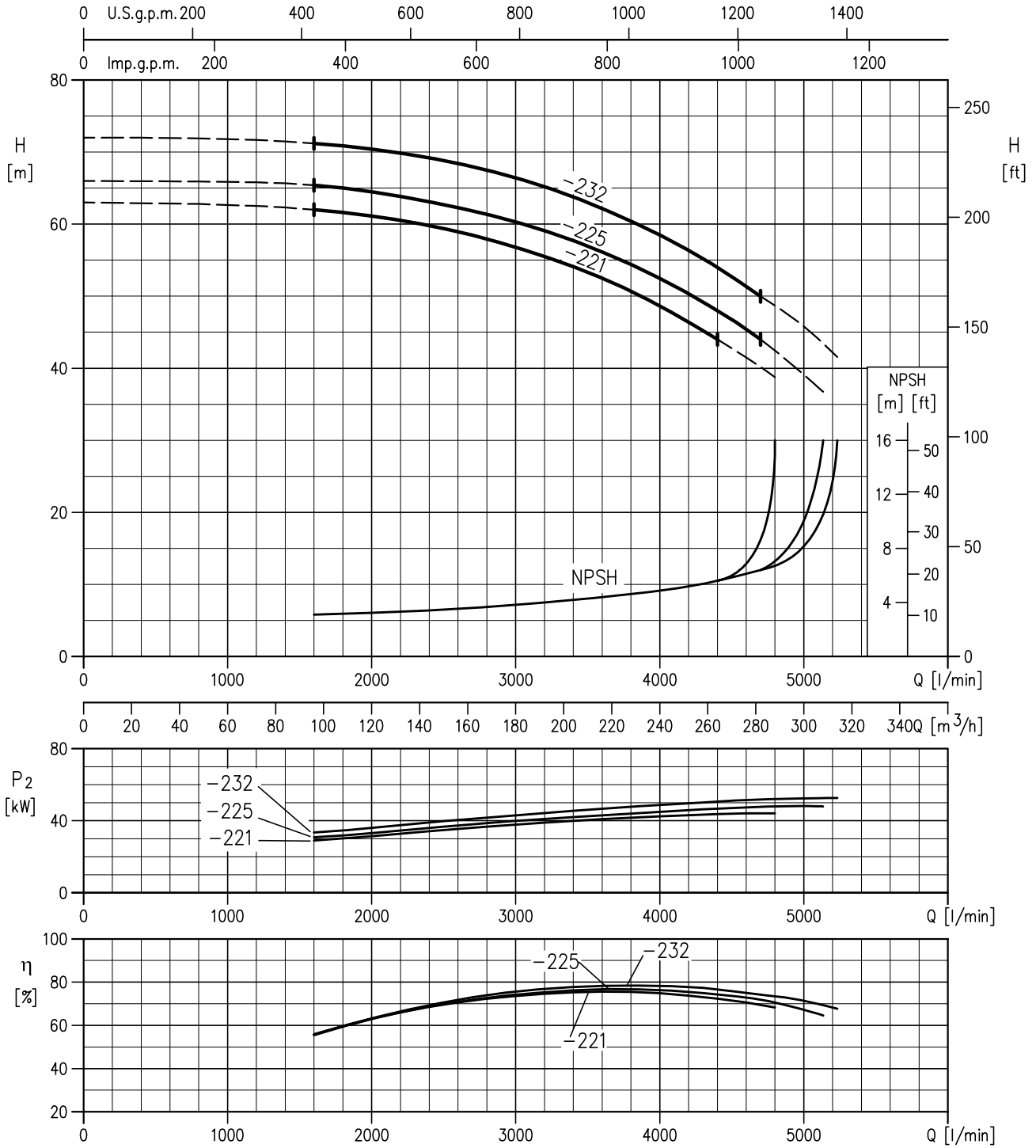

The contents of the publication should not be regarded as binding. EBARA Pompa Europe S.p.A. reserves the right to effect any modification it deems necessary, without prior notice.

PERFORMANCE CURVES for series ENR 100-250 (2/2) (impeller diameter - from 242 to 255 mm) in accordance with ISO 9906 Annex A

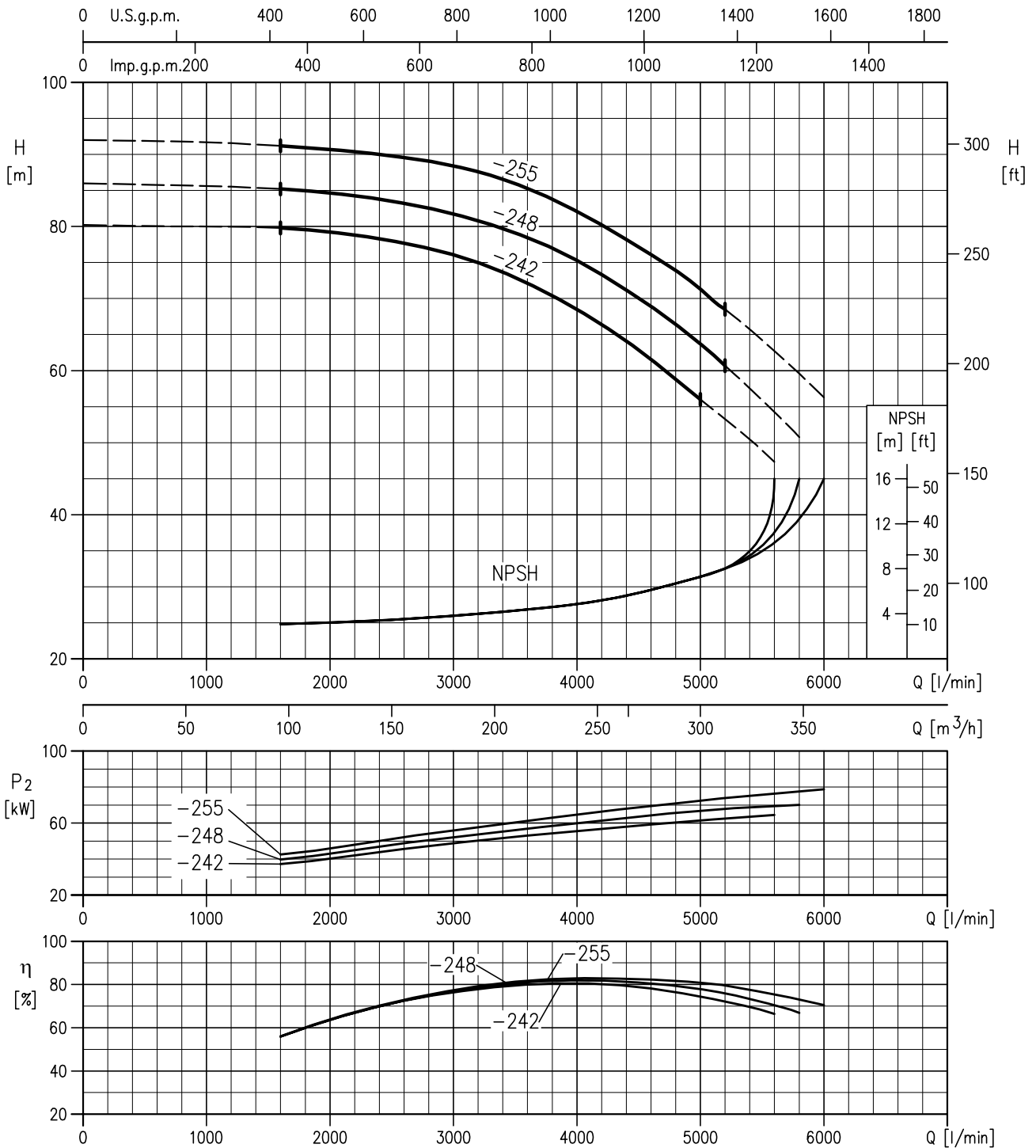

The contents of the publication should not be regarded as binding. EBARA Pumps Europe S.p.A. reserves the right to effect any modification it deems necessary, without prior notice.

**TABLE OF BASE-JOINT ELECTRICAL MODELS**

Pump	Size diameter impeller	Motor electric [kW]	FFS11/FFBE11	Pump pilot	FFS21/FFBE21	Pump pilot
3PF	32-160-166	3	FFS 11 3PS 32-160-166/3	COMPACT A/10	FFS 21 3PS 32-160-166/3	COMPACT A/10
3PF	32-200-186	4	FFS 11 3PS 32-200-186/4	COMPACT A/10	FFS 21 3PS 32-200-186/4	COMPACT A/10
3PF	32-200-200	5,5	FFS 11 3PS 32-200-200/5.5	COMPACT A/12	FFS 21 3PS 32-200-200/5.5	COMPACT A/12
3PF	32-200-224	7,5	FFS 11 3PS 32-200-224/7.5	COMPACT A/15	FFS 21 3PS 32-200-224/7.5	COMPACT A/15
ENR	32-250-245	11	FFBE 11 ENRS 32-250-245/11	MATRIX 5-9T/2.2	FFBE 21 ENRS 32-250-245/11	MATRIX 5-9T/2.2
ENR	32-250-255	15	FFBE 11 ENRS 32-250-255/15	MATRIX 5-9T/2.2	FFBE 21 ENRS 32-250-255/15	MATRIX 5-9T/2.2
3PF	40-160-166	5,5	FFS 11 3PS 40-160-166/5.5	COMPACT A/10	FFS 21 3PS 40-160-166/5.5	COMPACT A/10
3PF	40-200-183	7,5	FFS 11 3PS 40-200-183/7.5	COMPACT A/10	FFS 21 3PS 40-200-183/7.5	COMPACT A/10
3PF	40-200-200	9,2	FFS 11 3PS 40-200-200/9.2	COMPACT A/12	FFS 21 3PS 40-200-200/9.2	COMPACT A/12
3PF	40-200-224	15	FFS 11 3PS 40-200-224/15	COMPACT A/15	FFS 21 3PS 40-200-224/15	COMPACT A/15
ENR	40-250-220	11	FFBE 11 ENRS 40-250-220/11	MATRIX 5-9T/2.2	FFBE 21 ENRS 40-250-220/11	MATRIX 5-9T/2.2
ENR	40-250-239	15	FFBE 11 ENRS 40-250-239/15	MATRIX 5-9T/2.2	FFBE 21 ENRS 40-250-239/15	MATRIX 5-9T/2.2
ENR	40-250-252	18,5	FFBE 11 ENRS 40-250-252/18.5	MATRIX 5-9T/2.2	FFBE 21 ENRS 40-250-252/18.5	MATRIX 5-9T/2.2
3PF	50-160-166	9,2	FFS 11 3PS 50-160-166/9.2	COMPACT A/10	FFS 21 3PS 50-160-166/9.2	COMPACT A/10
3PF	50-200-197	11	FFS 11 3PS 50-200-197/11	COMPACT A/12	FFS 21 3PS 50-200-197/11	COMPACT A/12
3PF	50-200-212	15	FFS 11 3PS 50-200-212/15	COMPACT A/15	FFS 21 3PS 50-200-212/15	COMPACT A/15
3PF	50-200-224	18,5	FFS 11 3PS 50-200-224/18.5	COMPACT A/15	FFS 21 3PS 50-200-224/18.5	COMPACT A/15
ENR	50-250-222	18,5	FFBE 11 ENRS 50-250-222/18.5	MATRIX 5-9T/2.2	FFBE 21 ENRS 50-250-222/18.5	MATRIX 5-9T/2.2
ENR	50-250-235	22	FFBE 11 ENRS 50-250-235/22	MATRIX 5-9T/2.2	FFBE 21 ENRS 50-250-235/22	MATRIX 5-9T/2.2
ENR	50-250-252	30	FFBE 11 ENRS 50-250-252/30	MATRIX 5-9T/2.2	FFBE 21 ENRS 50-250-252/30	MATRIX 5-9T/2.2
3PF	65-200-190	15	FFS 11 3PS 65-200-190/15	COMPACT A/12	FFS 21 3PS 65-200-190/15	COMPACT A/12
3PF	65-200-201	18,5	FFS 11 3PS 65-200-201/18.5	COMPACT A/12	FFS 21 3PS 65-200-201/18.5	COMPACT A/12
3PF	65-200-208	22	FFS 11 3PS 65-200-208/22	COMPACT A/15	FFS 21 3PS 65-200-208/22	COMPACT A/15
3PF	65-200-212	30	FFS 11 3PS 65-200-212/30	COMPACT A/15	FFS 21 3PS 65-200-212/30	COMPACT A/15
ENR	65-250-226	30	FFBE 11 ENRS 65-250-226/30	MATRIX 5-9T/2.2	FFBE 21 ENRS 65-250-226/30	MATRIX 5-9T/2.2
ENR	65-250-237	37	FFBE 11 ENRS 65-250-237/37	MATRIX 5-9T/2.2	FFBE 21 ENRS 65-250-237/37	MATRIX 5-9T/2.2
ENR	65-250-252	45	FFBE 11 ENRS 65-250-252/45	MATRIX 5-9T/2.2	FFBE 21 ENRS 65-250-252/45	MATRIX 5-9T/2.2
ENR	80-200-190	22	FFBE 11 ENRS 80-200-190/22	AGA 300T SUR	FFBE 21 ENRS 80-200-190/22	AGA 300T SUR
ENR	80-200-199	30	FFBE 11 ENRS 80-200-199/30	AGA 300T SUR	FFBE 21 ENRS 80-200-199/30	AGA 300T SUR
ENR	80-200-207	37	FFBE 11 ENRS 80-200-207/37	AGA 300T SUR	FFBE 21 ENRS 80-200-207/37	AGA 300T SUR
ENR	80-200-214	45	FFBE 11 ENRS 80-200-214/45	AGA 300T SUR	FFBE 21 ENRS 80-200-214/45	AGA 300T SUR
ENR	80-250-222	37	FFBE 11 ENRS 80-250-222/37	MATRIX 5-9T/2.2	FFBE 21 ENRS 80-250-222/37	MATRIX 5-9T/2.2
ENR	80-250-234	45	FFBE 11 ENRS 80-250-234/45	MATRIX 5-9T/2.2	FFBE 21 ENRS 80-250-234/45	MATRIX 5-9T/2.2
ENR	80-250-243	55	FFBE 11 ENRS 80-250-243/55	MATRIX 5-9T/2.2	FFBE 21 ENRS 80-250-243/55	MATRIX 5-9T/2.2
ENR	80-250-255	75	FFBE 11 ENRS 80-250-255/75	MATRIX 5-9T/2.2	FFBE 21 ENRS 80-250-255/75	MATRIX 5-9T/2.2
ENR	100-200-182	22	FFBE 11 ENRS 100-200-182/22	AGA 300T SUR	FFBE 21 ENRS 100-200-182/22	AGA 300T SUR
ENR	100-200-194	30	FFBE 11 ENRS 100-200-194/30	AGA 300T SUR	FFBE 21 ENRS 100-200-194/30	AGA 300T SUR
ENR	100-200-201	37	FFBE 11 ENRS 100-200-201/37	AGA 300T SUR	FFBE 21 ENRS 100-200-201/37	AGA 300T SUR
ENR	100-200-209	45	FFBE 11 ENRS 100-200-209/45	AGA 300T SUR	FFBE 21 ENRS 100-200-209/45	AGA 300T SUR
ENR	100-200-213	55	FFBE 11 ENRS 100-200-213/55	AGA 300T SUR	FFBE 21 ENRS 100-200-213/55	AGA 300T SUR
ENR	100-250-221	45	FFBE 11 ENRS 100-250-221/45	MATRIX 5-9T/2.2	FFBE 21 ENRS 100-250-221/45	MATRIX 5-9T/2.2
ENR	100-250-232	55	FFBE 11 ENRS 100-250-232/55	MATRIX 5-9T/2.2	FFBE 21 ENRS 100-250-232/55	MATRIX 5-9T/2.2
ENR	100-250-248	75	FFBE 11 ENRS 100-250-248/75	MATRIX 5-9T/2.2	FFBE 21 ENRS 100-250-248/75	MATRIX 5-9T/2.2
ENR	100-250-255	90	FFBE 11 ENRS 100-250-255/90	MATRIX 5-9T/2.2	FFBE 21 ENRS 100-250-255/90	MATRIX 5-9T/2.2

For performance data refer to pages 14 to 32.

### FFS11 DIMENSIONS - 3PS ELECTRICAL PUMP+PILOT

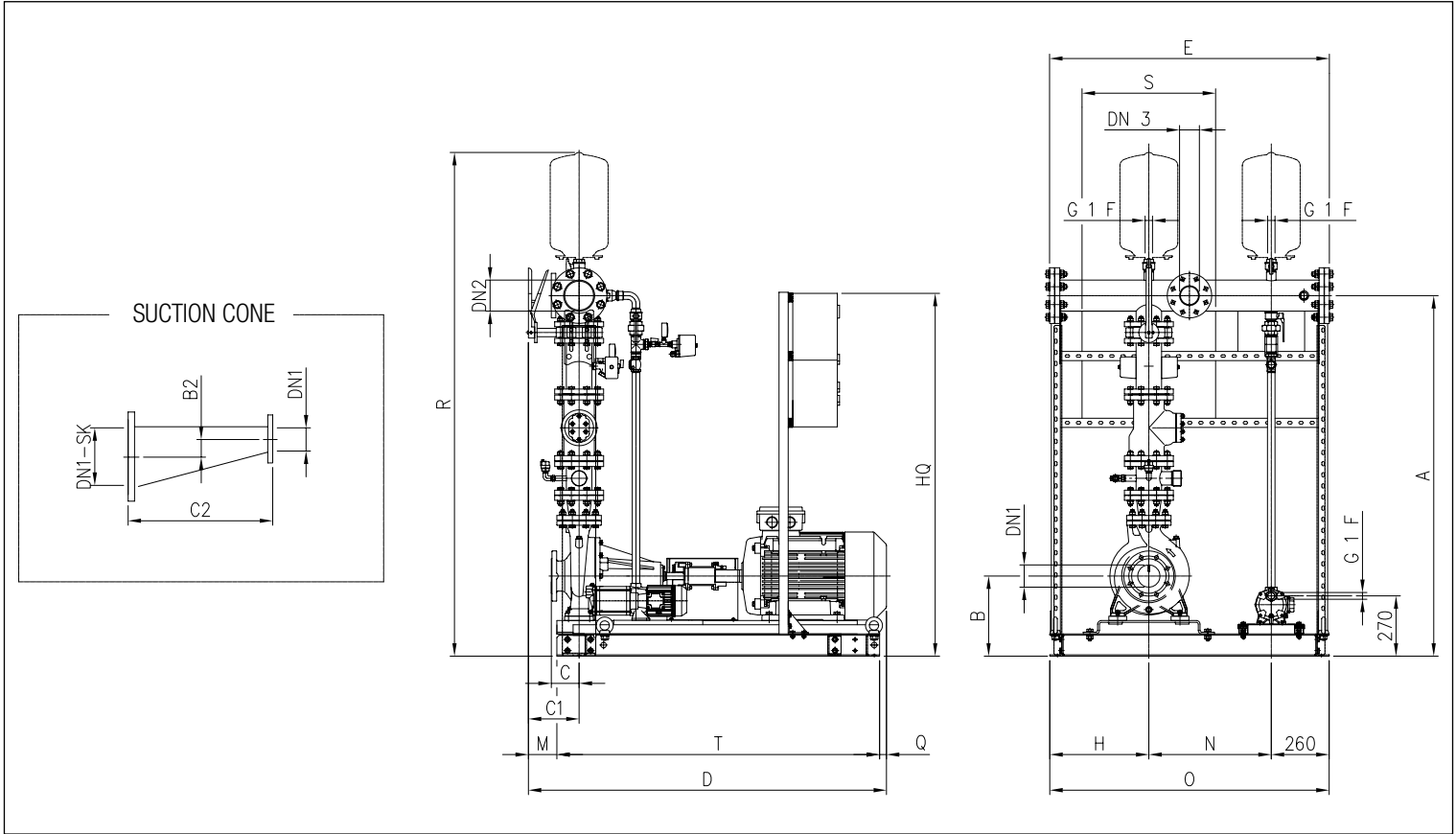

### DIMENSIONS CHART

Model	Pilot pump	Dimensions [mm]																				Weight [kg]				
		A	B	C	C1	D	E	H	DN1	DN2	DN3	R	M	N	O	Q	HQ	S	T	DN1-SK [1]	[2]		B2 [1]	[2]	C2 [1]	[2]
FFS11 3PS 32-160-166/3	COMPACT A 10	1075	280	80	165	1215	1035	330	50	65	G1½	1690	65	450	1040	-	1230	400	1150	65	80	10	15	72	120	237
FFS11 3PS 32-200-186/4	COMPACT A 10	1125	310	80	165	1215	1035	330	50	65	G1½	1740	65	450	1040	-	1230	400	1150	65	80	10	15	72	120	254
FFS11 3PS 32-200-200/5.5	COMPACT A/12	1125	310	80	165	1215	1035	330	50	65	G1½	1740	65	450	1040	-	1260	400	1150	65	80	10	15	72	120	270
FFS11 3PS 32-200-224/7.5	COMPACT A/15	1125	310	80	165	1215	1035	330	50	65	G1½	1740	65	450	1040	-	1260	400	1150	65	80	10	15	72	120	276
FFS11 3PS 40-160-166/5.5	COMPACT A/10	1165	280	80	170	1220	1040	330	65	80	G2	1780	70	450	1040	-	1230	400	1150	100	80	20	15	135	120	270
FFS11 3PS 40-200-183/7.5	COMPACT A/10	1210	310	100	170	1220	1040	330	65	80	G3	1825	70	450	1040	-	1260	400	1150	100	80	20	15	135	120	289
FFS11 3PS 40-200-200/9.2	COMPACT A/12	1210	310	100	170	1220	1040	330	65	80	G4	1825	70	450	1040	-	1360	500	1150	100	80	20	15	135	120	303
FFS11 3PS 40-200-224/15	COMPACT A/15	1210	310	100	170	1240	1040	330	65	80	G5	1825	70	450	1040	20	1410	500	1150	100	80	20	15	135	120	349
FFS11 3PS 5Q-160-166/9.2	COMPACT A/10	1425	310	100	180	1230	1040	330	65	100	G2½	2055	80	450	1040	-	1360	500	1150	125	80	30	15	205	120	329
FFS11 3PS 5Q-200-197/11	COMPACT A/12	1445	310	100	180	1250	1040	330	65	100	G2½	2075	80	450	1040	20	1410	500	1150	125	80	30	15	205	120	360
FFS11 3PS 5Q-200-212/15	COMPACT A/12	1445	310	100	180	1250	1040	330	65	100	G2½	2075	80	450	1040	20	1410	500	1150	125	80	30	15	205	120	377
FFS11 3PS 5Q-200-224/18.5	COMPACT A/15	1445	310	100	180	1295	1040	330	65	100	G2½	2075	80	450	1040	65	1410	500	1150	125	80	30	15	205	120	391
FFS11 3PS 65-200-190/15	COMPACT A/12	1555	330	100	230	1340	1040	330	80	125	DN80	2200	130	450	1040	60	1430	500	1150	150	200	35	60	235	375	421
FFS11 3PS 65-200-201/18.5	COMPACT A 12	1555	330	100	230	1385	1040	330	80	125	DN81	2200	130	450	1040	105	1530	600	1150	150	200	35	60	235	375	435
FFS11 3PS 65-200-208/22	COMPACT A 15	1555	330	100	230	1420	1040	330	80	125	DN82	2200	130	450	1040	140	1530	600	1150	150	200	35	60	235	375	519
FFS11 3PS 65-200-212/30	COMPACT A 15	1585	360	100	230	1580	1255	445	80	125	DN83	2230	130	550	1255	140	1630	600	1450	150	200	35	60	235	375	628

[1]= Underhead  
[2]= Overhead

## FFBE11 FIRE-FIGHTING UNITS

### FFBE11 DIMENSIONS - ENRS ELECTRICAL PUMP+PILOT

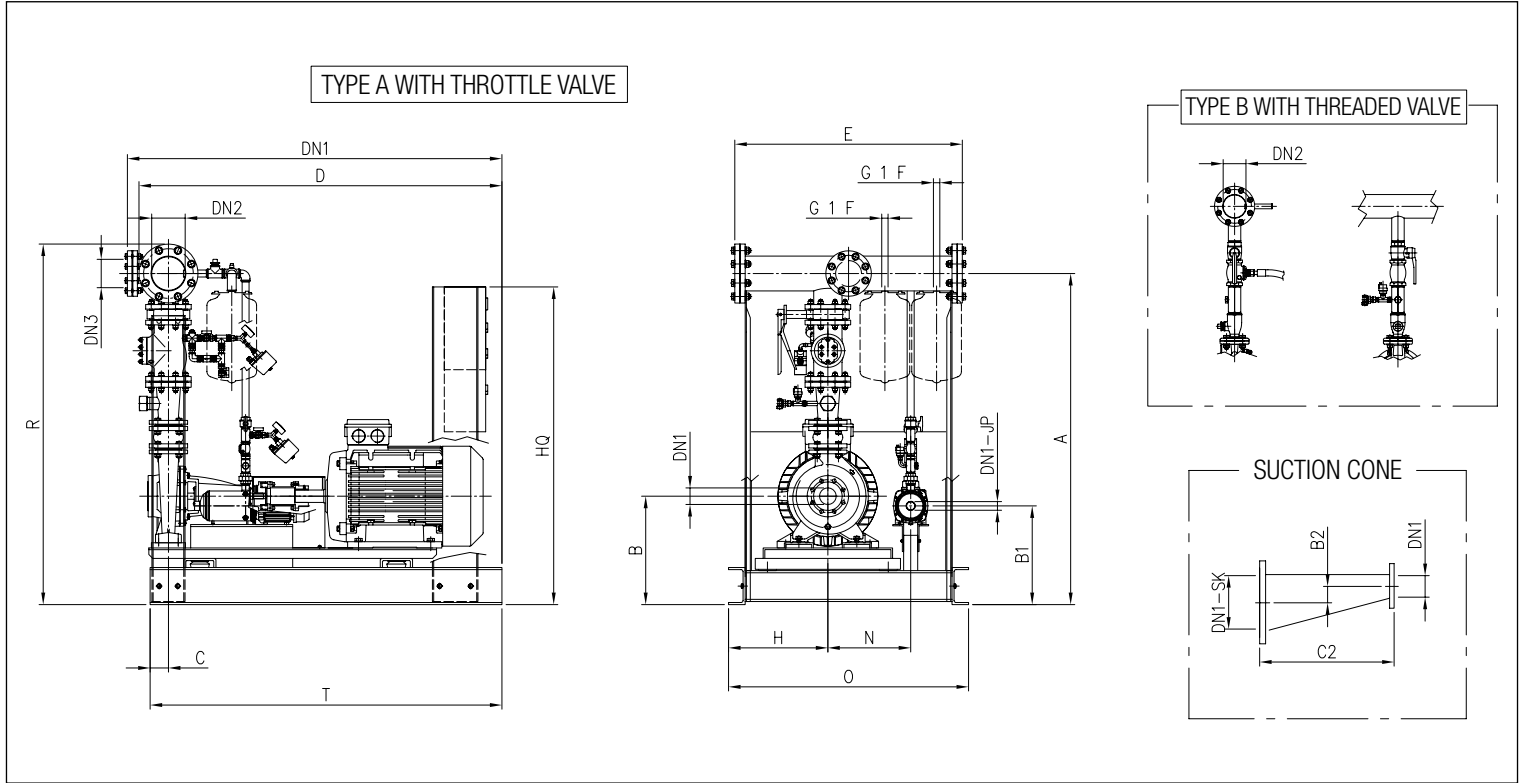

### DIMENSIONS CHART

Model	Pilot pump	Type	Dimensions [mm]																						
			A	B	B1	C	D	D1	E	H	N	DN1	DN1-JP	DN2	DN3	R	HQ	O	T	DN1-SK [1] [2]	B2 [1] [2]	C2 [1] [2]			
FFBE11 ENRS32-250-245/11E+2.2P	MATRIX 5-9T/2.2	B	973	385	330	65	1228	1203	890	315	310	50	G1¼	65	G1½	1066	1505	910	1200	65	80	8	14	180	185
FFBE11 ENRS32-250-255/15E+2.2P	MATRIX 5-9T/2.2	B	973	385	330	65	1228	1203	890	315	310	50	G1¼	65	G1½	1066	1505	910	1200	65	80	8	14	180	185
FFBE11 ENRS40-250-220/11E+2.2P	MATRIX 5-9T/2.2	B	1034	385	330	65	1235	1214	894	315	310	65	G1¼	80	G2	1134	1505	910	1200	100	100	19	19	197	197
FFBE11 ENRS40-250-239/15E+2.2P	MATRIX 5-9T/2.2	B	1034	385	330	65	1235	1214	894	315	310	65	G1¼	80	G2	1134	1505	910	1200	100	100	19	19	197	197
FFBE11 ENRS40-250-252/18.5E+2.2P	MATRIX 5-9T/2.2	B	1034	385	330	65	1235	1214	894	315	310	65	G1¼	80	G2	1134	1505	910	1200	100	100	19	19	197	197
FFBE11 ENRS50-250-222/18.5E+2.2P	MATRIX 5-9T/2.2	B	1232	385	330	65	1245	1232	898	315	310	65	G1¼	100	G2½	1232	1505	910	1200	100	125	19	32	197	227
FFBE11 ENRS50-250-235/22E+2.2P	MATRIX 5-9T/2.2	B	1154	417	350	65	1445	1432	998	370	340	65	G1¼	100	G2½	1264	1517	1020	1400	100	125	19	32	197	227
FFBE11 ENRS50-250-252/30E+2.2P	MATRIX 5-9T/2.2	B	1174	437	350	65	1445	1432	998	370	340	65	G1¼	100	G2½	1284	1517	1020	1400	100	125	19	32	197	227
FFBE11 ENRS65-250-226/30E+2.2P	MATRIX 5-9T/2.2	A	1443	437	350	65	1460	1485	1102	370	340	80	G1¼	125	80	1568	1517	1020	1400	150	200	40	65	340	550
FFBE11 ENRS65-250-237/37E+2.2P	MATRIX 5-9T/2.2	A	1443	437	350	65	1460	1485	1102	370	340	80	G1¼	125	80	1568	1517	1020	1400	150	200	40	65	340	550
FFBE11 ENRS65-250-252/45E+2.2P	MATRIX 5-9T/2.2	A	1521	515	480	125	1700	1725	1102	450	430	80	G1¼	125	80	1646	1535	1160	1700	150	200	40	65	340	550
FFBE11 ENRS80-200-190/22E+2.2P	AGA 300T SUR	A	1517	417	430	65	1478	1501	1002	370	340	100	G1½	150	100	1660	1517	1020	1400	200	250	52	80	450	650
FFBE11 ENRS80-200-199/30E+2.2P	AGA 300T SUR	A	1537	437	430	65	1478	1501	1002	370	340	100	G1½	150	100	1680	1517	1020	1400	200	250	52	80	450	650
FFBE11 ENRS80-200-207/37E+2.2P	AGA 300T SUR	A	1537	490	430	65	1478	1501	1002	370	430	100	G1½	150	100	1680	1517	1020	1400	200	250	52	80	450	650
FFBE11 ENRS80-200-214/45E+2.2P	AGA 300T SUR	A	1615	515	560	125	1718	1741	1102	450	430	100	G1½	150	100	1758	1535	1160	1700	200	250	52	80	450	650
FFBE11 ENRS80-250-222/37E+2.2P	MATRIX 5-9T/2.2	A	1567	437	350	65	1710	1501	1002	370	340	100	G1¼	150	100	1710	1517	1020	1400	200	250	53	80	450	450
FFBE11 ENRS80-250-234/45E+2.2P	MATRIX 5-9T/2.2	A	1645	515	480	125	1788	1741	1102	450	430	100	G1¼	150	100	1788	1535	1160	1700	200	200	53	80	450	450
FFBE11 ENRS80-250-243/55E+2.2P	MATRIX 5-9T/2.2	A	1670	540	480	125	1813	1741	1102	450	430	100	G1¼	150	100	1813	1535	1160	1700	200	200	53	80	450	450
FFBE11 ENRS80-250-255/75E+2.2P	MATRIX 5-9T/2.2	A	1700	570	480	125	1843	1741	1102	450	430	100	G1¼	150	100	1843	1535	1160	1700	200	200	53	80	450	450
FFBE11 ENRS100-200-182/22E+2.2P	AGA 300T SUR	A	1685	437	430	65	1855	1529	1006	370	340	125	G1½	200	125	1855	1517	1020	1400	250	250	52	52	550	550
FFBE11 ENRS100-200-194/30E+2.2P	AGA 300T SUR	A	1685	437	430	65	1855	1529	1006	370	340	125	G1½	200	125	1855	1517	1020	1400	250	250	52	52	550	550
FFBE11 ENRS100-200-201/37E+2.2P	AGA 300T SUR	A	1685	437	430	65	1855	1529	1106	370	340	125	G1½	200	125	1855	1517	1020	1400	250	250	52	52	550	550
FFBE11 ENRS100-200-209/45E+2.2P	AGA 300T SUR	A	1763	515	560	125	1933	1769	1106	450	430	125	G1½	200	125	1933	1535	1160	1700	250	250	52	52	550	550
FFBE11 ENRS100-200-213/55E+2.2P	AGA 300T SUR	A	1788	540	560	125	1958	1769	1106	450	430	125	G1½	200	125	1958	1535	1160	1700	250	250	67	67	550	550
FFBE11 ENRS100-250-221/45E+2.2P	MATRIX 5-9T/2.2	A	1793	515	480	125	1933	1769	1106	450	430	125	G1¼	200	125	1933	1535	1160	1700	250	250	67	67	550	550
FFBE11 ENRS100-250-232/55E+2.2P	MATRIX 5-9T/2.2	A	1788	540	480	125	1958	1769	1106	450	430	125	G1¼	200	125	1958	1535	1160	1700	250	250	67	67	550	550
FFBE11 ENRS100-250-248/75E+2.2P	MATRIX 5-9T/2.2	A	1818	570	480	125	1988	1769	1106	450	430	125	G1¼	200	125	1988	1535	1160	1700	250	250	67	67	550	550
FFBE11 ENRS100-250-255/90E+2.2P	MATRIX 5-9T/2.2	A	1818	570	480	125	1988	1769	1106	450	430	125	G1¼	200	125	1988	1535	1160	1700	250	250	67	67	550	550

[1]= Underhead  
[2]= Overhead

The contents of this publication should not be regarded as binding. EBARA Pumps Europe S.p.A. reserves the right to effect any modification it deems necessary, without prior notice.

# FFS-FFB

## FFS21 FIRE-FIGHTING UNITS

### FFS21 DIMENSIONS - 3PS ELECTRICAL PUMP+PILOT

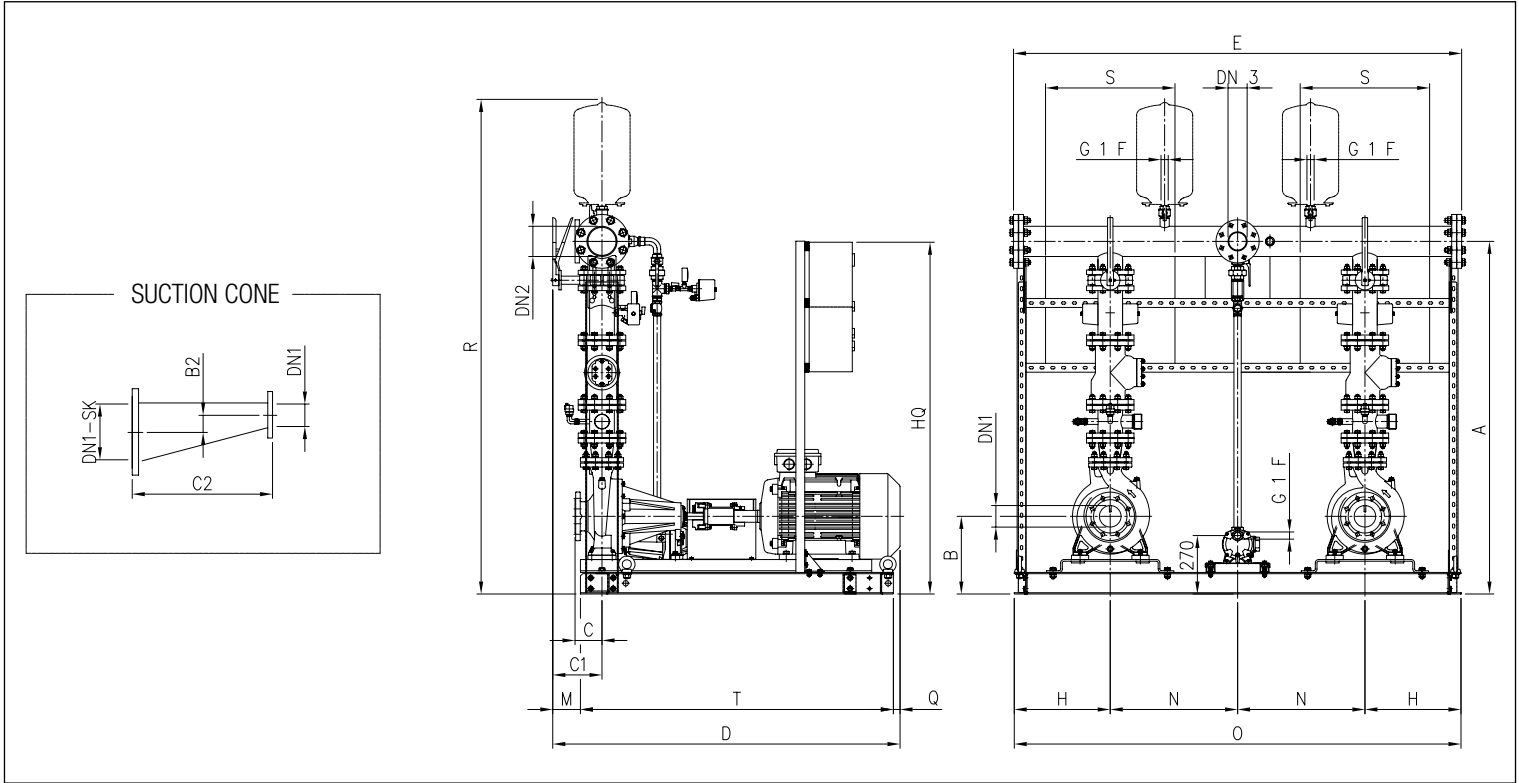

### DIMENSIONS CHART

Model	Pilot pump	Dimensions [mm]																				Weight [kg]				
		A	B	C	C1	D	E	H	DN1	DN2	DN3	R	M	N	O	Q	HQ	S	T	DN1-SK [1]	[2]		B2 [1]	[2]	C1 [1]	[2]
FFS21 3PS 32-160-166/3	COMPACT A 10	1075	280	80	165	1215	1035	330	50	65	G1½	1690	65	450	1040	-	1230	400	1150	65	80	10	15	72	120	359
FFS21 3PS 32-200-186/4	COMPACT A 10	1125	310	80	165	1215	1035	330	50	65	G1½	1740	65	450	1040	-	1230	400	1150	65	80	10	15	72	120	393
FFS21 3PS 32-200-200/5.5	COMPACT A/12	1125	310	80	165	1215	1035	330	50	65	G1½	1740	65	450	1040	-	1260	400	1150	65	80	10	15	72	120	426
FFS21 3PS 32-200-224/7.5	COMPACT A/15	1125	310	80	165	1215	1035	330	50	65	G1½	1740	65	450	1040	-	1260	400	1150	65	80	10	15	72	120	437
FFS21 3PS 40-160-166/5.5	COMPACT A/10	1165	280	80	170	1220	1040	330	65	80	G2	1780	70	450	1040	-	1230	400	1150	100	80	20	15	135	120	422
FFS21 3PS 40-200-183/7.5	COMPACT A/10	1210	310	100	170	1220	1040	330	65	80	G3	1825	70	450	1040	-	1260	400	1150	100	80	20	15	135	120	459
FFS21 3PS 40-200-200/9.2	COMPACT A/12	1210	310	100	170	1220	1040	330	65	80	G4	1825	70	450	1040	-	1360	500	1150	100	80	20	15	135	120	486
FFS21 3PS 40-200-224/15	COMPACT A/15	1210	310	100	170	1240	1040	330	65	80	G5	1825	70	450	1040	20	1410	500	1150	100	80	20	15	135	120	577
FFS21 3PS 50-160-166/9.2	COMPACT A/10	1425	310	100	180	1230	1040	330	65	100	G2½	2055	80	450	1040	-	1360	500	1150	125	80	30	15	205	120	521
FFS21 3PS 50-200-197/11	COMPACT A/12	1445	310	100	180	1250	1040	330	65	100	G2½	2075	80	450	1040	20	1410	500	1150	125	80	30	15	205	120	582
FFS21 3PS 50-200-212/15	COMPACT A/12	1445	310	100	180	1250	1040	330	65	100	G2½	2075	80	450	1040	20	1410	500	1150	125	80	30	15	205	120	616
FFS21 3PS 50-200-224/18.5	COMPACT A/15	1445	310	100	180	1295	1040	330	65	100	G2½	2075	80	450	1040	65	1410	500	1150	125	80	30	15	205	120	644
FFS21 3PS 65-200-190/15	COMPACT A/12	1555	330	100	230	1340	1040	330	80	125	DN80	2200	130	450	1040	60	1430	500	1150	150	200	35	60	235	375	715
FFS21 3PS 65-200-201/18.5	COMPACT A 12	1555	330	100	230	1385	1040	330	80	125	DN81	2200	130	450	1040	105	1530	600	1150	150	200	35	60	235	375	735
FFS21 3PS 65-200-208/22	COMPACT A 15	1555	330	100	230	1420	1040	330	80	125	DN82	2200	130	450	1040	140	1530	600	1150	150	200	35	60	235	375	881
FFS21 3PS 65-200-212/30	COMPACT A 15	1585	360	100	230	1580	1255	445	80	125	DN83	2230	130	550	1255	140	1630	600	1450	150	200	35	60	235	375	1113

[1]= Underhead  
[2]= Overhead

### FFBE21 DIMENSIONS - ENRS ELECTRICAL PUMP+PILOT

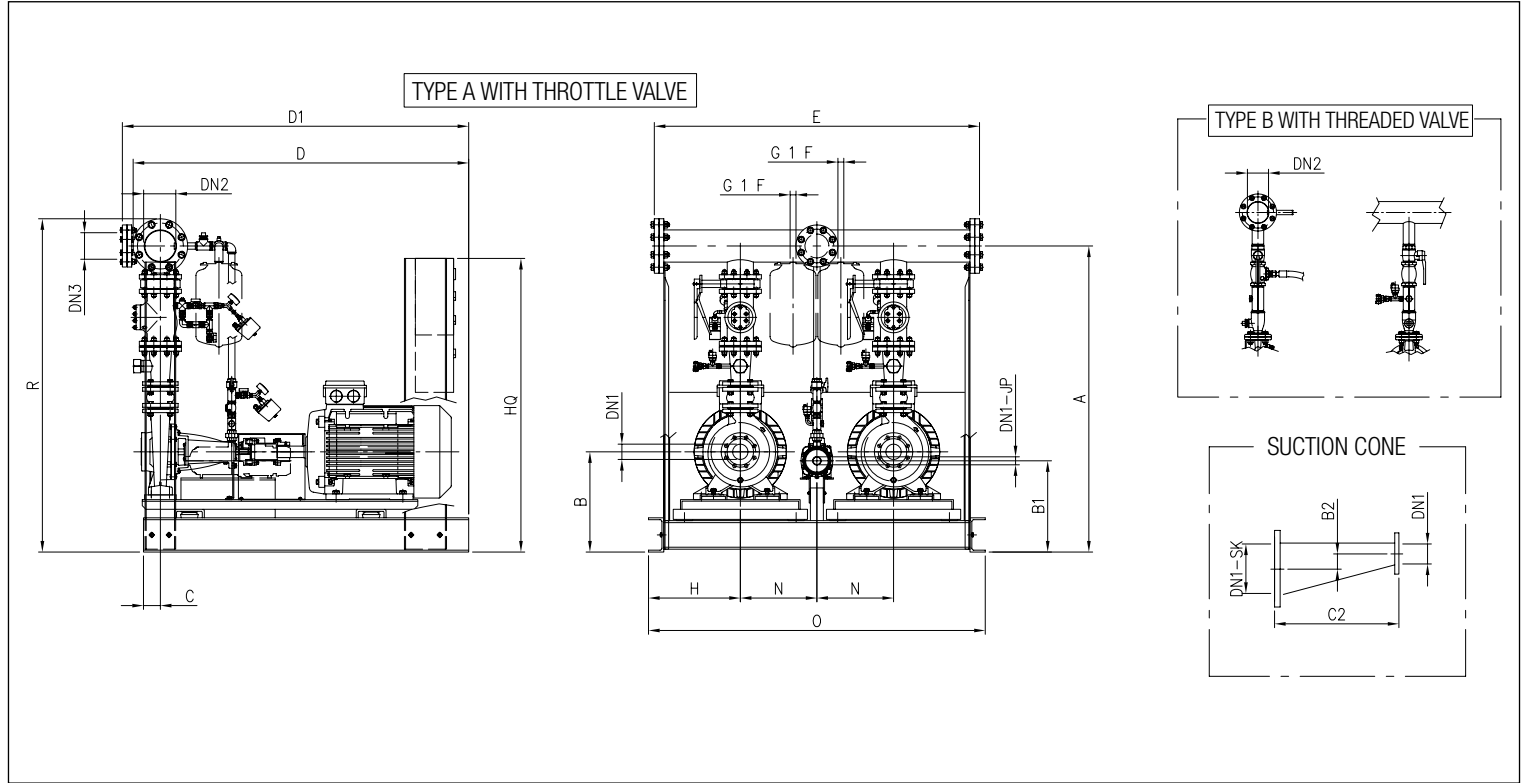

### DIMENSIONS CHART

Model	Pilot pump	Type	Dimensions [mm]																						
			A	B	B1~	C	D	D1	E	H	N	DN1	DN1-JP	DN2	DN3	R	HQ	O	T	DN1-SK [1] [2]	B2 [1] [2]	C2 [1] [2]			
FFBE21 ENRS32-250-245/11E+2.2P	MATRIX 5-9T/2.2	B	973	385	330	65	1228	1203	1230	315	310	50	G1¼	65	G1½	1066	1505	1250	1200	65	80	8	14	180	185
FFBE21 ENRS32-250-255/15E+2.2P	MATRIX 5-9T/2.2	B	973	385	330	65	1228	1203	1230	315	310	50	G1¼	65	G1½	1066	1505	1250	1200	65	80	8	14	180	185
FFBE21 ENRS40-250-220/11E+2.2P	MATRIX 5-9T/2.2	B	1034	385	330	65	1235	1214	1234	315	310	65	G1¼	80	G2	1134	1505	1250	1200	100	100	19	19	197	197
FFBE21 ENRS40-250-239/15E+2.2P	MATRIX 5-9T/2.2	B	1034	385	330	65	1235	1214	1234	315	310	65	G1¼	80	G2	1134	1505	1250	1200	100	100	19	19	197	197
FFBE21 ENRS40-250-252/18.5E+2.2P	MATRIX 5-9T/2.2	B	1034	385	330	65	1235	1214	1234	315	310	65	G1¼	80	G2	1134	1505	1250	1200	100	100	19	19	197	197
FFBE21 ENRS50-250-222/18.5E+2.2P	MATRIX 5-9T/2.2	B	1122	385	330	65	1245	1232	1238	315	310	65	G1¼	100	G2½	1232	1505	1250	1200	100	125	19	32	197	227
FFBE21 ENRS50-250-235/22E+2.2P	MATRIX 5-9T/2.2	B	1154	417	350	65	1445	1432	1403	370	340	65	G1¼	100	G2½	1264	1517	1420	1400	100	125	19	32	197	227
FFBE21 ENRS50-250-252/30E+2.2P	MATRIX 5-9T/2.2	B	1174	437	350	65	1445	1432	1403	370	340	65	G1¼	100	G2½	1284	1517	1420	1400	100	125	19	32	197	227
FFBE21 ENRS65-250-226/30E+2.2P	MATRIX 5-9T/2.2	A	1443	437	350	65	1460	1485	1407	370	340	80	G1¼	125	80	1568	1517	1420	1400	150	200	40	65	340	550
FFBE21 ENRS65-250-237/37E+2.2P	MATRIX 5-9T/2.2	A	1443	437	350	65	1460	1485	1407	370	340	80	G1¼	125	80	1568	1517	1420	1400	150	200	40	65	340	550
FFBE21 ENRS65-250-252/45E+2.2P	MATRIX 5-9T/2.2	A	1521	515	480	125	1700	1725	1697	450	430	80	G1¼	125	80	1646	1535	1760	1700	150	200	40	65	340	550
FFBE21 ENRS80-200-190/22E+2.2P	AGA 300T SUR	A	1517	417	430	65	1478	1501	1407	370	340	100	G1½	150	100	1660	1517	1420	1400	200	250	52	80	450	650
FFBE21 ENRS80-200-199/30E+2.2P	AGA 300T SUR	A	1537	437	430	65	1478	1501	1407	370	340	100	G1½	150	100	1680	1517	1420	1400	200	250	52	80	450	650
FFBE21 ENRS80-200-207/37E+2.2P	AGA 300T SUR	A	1537	437	430	65	1478	1501	1407	370	340	100	G1½	150	100	1680	1517	1420	1400	200	250	52	80	450	650
FFBE21 ENRS80-200-214/45E+2.2P	AGA 300T SUR	A	1615	515	560	125	1718	1741	1697	450	430	100	G1½	150	100	1758	1535	1760	1700	200	250	52	80	450	650
FFBE21 ENRS80-250-222/37E+2.2P	MATRIX 5-9T/2.2	A	1567	437	350	65	1478	1501	1407	370	340	100	G1¼	150	100	1710	1517	1420	1400	200	200	200	200	450	450
FFBE21 ENRS80-250-234/45E+2.2P	MATRIX 5-9T/2.2	A	1645	515	480	125	1718	1741	1697	450	430	100	G1¼	150	100	1788	1535	1760	1700	200	200	200	200	450	450
FFBE21 ENRS100-200-209/45E+2.2P	AGA 300T SUR	A	1763	515	480	125	1745	1769	1701	450	430	100	G1¼	150	100	1813	1535	1760	1700	200	200	200	200	450	450
FFBE21 ENRS80-250-255/75E+2.2P	MATRIX 5-9T/2.2	A	1700	570	480	125	1718	1741	1697	450	430	100	G1¼	150	100	1843	1535	1760	1700	200	200	200	200	450	450
FFBE21 ENRS100-200-182/22E+2.2P	AGA 300T SUR	A	1685	437	430	65	1505	1529	1411	370	340	125	G1½	200	125	1855	1517	1420	1400	250	250	67	67	550	550
FFBE21 ENRS100-200-194/30E+2.2P	AGA 300T SUR	A	1685	437	430	65	1505	1529	1411	370	340	125	G1½	200	125	1855	1517	1420	1400	250	250	67	67	550	550
FFBE21 ENRS100-200-201/37E+2.2P	AGA 300T SUR	A	1685	437	430	65	1505	1529	1411	370	340	125	G1½	200	125	1855	1517	1420	1400	250	250	67	67	550	550
FFBE21 ENRS100-200-209/45E+2.2P	AGA 300T SUR	A	1763	515	560	125	1745	1769	1701	450	430	125	G1¼	200	125	1933	1535	1760	1700	250	250	67	67	550	550
FFBE21 ENRS100-200-213/55E+2.2P	AGA 300T SUR	A	1788	540	560	125	1745	1769	1701	450	430	125	G1½	200	125	1958	1535	1760	1700	250	250	67	67	550	550
FFBE21 ENRS100-250-22¼/45E+2.2P	MATRIX 5-9T/2.2	A	1763	515	480	125	1745	1769	1701	450	430	125	G1¼	200	125	1933	1535	1760	1700	250	250	67	67	620	620
FFBE21 ENRS100-250-232/55E+2.2P	MATRIX 5-9T/2.2	A	1788	540	480	125	1745	1769	1701	450	430	125	G1¼	200	125	1958	1535	1760	1700	250	250	67	67	620	620
FFBE21 ENRS100-250-248/75E+2.2P	MATRIX 5-9T/2.2	A	1818	570	480	125	1745	1769	1701	450	430	125	G1¼	200	125	1988	1535	1760	1700	250	250	67	67	620	620
FFBE21 ENRS100-250-255/90E+2.2P	MATRIX 5-9T/2.2	A	1818	570	480	125	1745	1769	1701	450	430	125	G1¼	200	125	1988	1535	1760	1700	250	250	67	67	620	620

[1]= Underhead  
[2]= Overhead

The contents of this publication should not be regarded as binding. EBARA Pumps Europe S.p.A. reserves the right to effect any modification it deems necessary, without prior notice.

## FFBD FIRE-FIGHTING UNITS

TABLE OF BASE-JOINT DIESEL MODELS

Pump	Size diameter impeller	Motor diesel [kW]	FFBD11	Pump pilot	FFBD21	Pump pilot
3PF	32-200-186	4,6	FFBD11 3PFS 32-200-186/4.6	COMPACT A/10	FFBD21 3PFS 32-200-186/4.6	COMPACT A/10
3PF	32-200-200	6,8	FFBD11 3PFS 32-200-200/6.8	COMPACT A/12	FFBD21 3PFS 32-200-200/6.8	COMPACT A/12
3PF	32-200-224	7,8	FFBD11 3PFS 32-200-224/7.8	COMPACT A/15	FFBD21 3PFS 32-200-224/7.8	COMPACT A/15
ENR	32-250-255	14,9	FFBD11 ENRS 32-250-255/14.9	MATRIX 5-9T/2.2	FFBD21 ENRS 32-250-255/14.9	MATRIX 5-9T/2.2
3PF	40-160-166	6,8	FFBD11 3PFS 40-160-166/6.8	COMPACT A/10	FFBD21 3PFS 40-160-166/6.8	COMPACT A/10
3PF	40-200-183	7,8	FFBD11 3PFS 40-200-183/7.8	COMPACT A/10	FFBD21 3PFS 40-200-183/7.8	COMPACT A/10
3PF	40-200-224	14,9	FFBD11 3PFS 40-200-224/14.9	COMPACT A/15	FFBD21 3PFS 40-200-224/14.9	COMPACT A/15
ENR	40-250-239	14,9	FFBD11 ENRS 40-250-239/14.9	MATRIX 5-9T/2.2	FFBD21 ENRS 40-250-239/14.9	MATRIX 5-9T/2.2
ENR	40-250-252	18,8	FFBD11 ENRS 40-250-252/18.8	MATRIX 5-9T/2.2	FFBD21 ENRS 40-250-252/18.8	MATRIX 5-9T/2.2
3PF	50-160-154	7,8	FFBD11 3PFS 50-160-154/7.8	COMPACT A/10	FFBD21 3PFS 50-160-154/7.8	COMPACT A/10
3PF	50-200-212	14,9	FFBD11 3PFS 50-200-212/14.9	COMPACT A/12	FFBD21 3PFS 50-200-212/14.9	COMPACT A/12
3PF	50-200-224	18,8	FFBD11 3PFS 50-200-224/18.8	COMPACT A/15	FFBD21 3PFS 50-200-224/18.8	COMPACT A/15
ENR	50-250-222	18,8	FFBD11 ENRS 50-250-222/18.8	MATRIX 5-9T/2.2	FFBD21 ENRS 50-250-222/18.8	MATRIX 5-9T/2.2
ENR	50-250-252	28,6	FFBD11 ENRS 50-250-252/28.6	MATRIX 5-9T/2.2	FFBD21 ENRS 50-250-252/28.6	MATRIX 5-9T/2.2
3PF	65-200-190	18,8	FFBD11 3PFS 65-200-190/18.8	COMPACT A/12	FFBD21 3PFS 65-200-190/18.8	COMPACT A/12
3PF	65-200-212	28,6	FFBD11 3PFS 65-200-212/28.6	COMPACT A/15	FFBD21 3PFS 65-200-212/28.6	COMPACT A/15
ENR	65-250-226	28,6	FFBD11 ENRS 65-250-226/28.6	MATRIX 5-9T/2.2	FFBD21 ENRS 65-250-226/28.6	MATRIX 5-9T/2.2
ENR	65-250-237	35	FFBD11 ENRS 65-250-237/35	MATRIX 5-9T/2.2	FFBD21 ENRS 65-250-237/35	MATRIX 5-9T/2.2
ENR	65-250-252	53	FFBD11 ENRS 65-250-252/53	MATRIX 5-9T/2.2	FFBD21 ENRS 65-250-252/53	MATRIX 5-9T/2.2
ENR	80-200-199	28,6	FFBD11 ENRS 80-200-199/28.6	AGA 300T SUR	FFBD21 ENRS 80-200-199/28.6	AGA 300T SUR
ENR	80-200-207	35	FFBD11 ENRS 80-200-207/35	AGA 300T SUR	FFBD21 ENRS 80-200-207/35	AGA 300T SUR
ENR	80-200-214	53	FFBD11 ENRS 80-200-214/53	AGA 300T SUR	FFBD21 ENRS 80-200-214/53	AGA 300T SUR
ENR	80-250-222	35	FFBD11 ENRS 80-250-222/35	MATRIX 5-9T/2.2	FFBD21 ENRS 80-250-222/35	MATRIX 5-9T/2.2
ENR	80-250-243	53	FFBD11 ENRS 80-250-243/53	MATRIX 5-9T/2.2	FFBD21 ENRS 80-250-243/53	MATRIX 5-9T/2.2
ENR	80-250-255	73,5	FFBD11 ENRS 80-250-255/73.5	MATRIX 5-9T/2.2	FFBD21 ENRS 80-250-255/73.5	MATRIX 5-9T/2.2
ENR	100-200-190	28,6	FFBD11 ENRS 100-200-190/28.6	AGA 300T SUR	FFBD21 ENRS 100-200-190/28.6	AGA 300T SUR
ENR	100-200-197	35	FFBD11 ENRS 100-200-197/35	AGA 300T SUR	FFBD21 ENRS 100-200-197/35	AGA 300T SUR
ENR	100-200-213	53	FFBD11 ENRS 100-200-213/53	AGA 300T SUR	FFBD21 ENRS 100-200-213/53	AGA 300T SUR
ENR	100-250-225	53	FFBD11 ENRS 100-250-225/53	MATRIX 5-9T/2.2	FFBD21 ENRS 100-250-225/53	MATRIX 5-9T/2.2
ENR	100-250-242	73,5	FFBD11 ENRS 100-250-242/73.5	MATRIX 5-9T/2.2	FFBD21 ENRS 100-250-242/73.5	MATRIX 5-9T/2.2
ENR	100-250-255	110	FFBD11 ENRS 100-250-255/110	MATRIX 5-9T/2.2	FFBD21 ENRS 100-250-255/110	MATRIX 5-9T/2.2

For performance data refer to pages 14 to 32.

### FFBD11 DIMENSIONS - 3PFS-ENRS MOTOR PUMP+PILOT

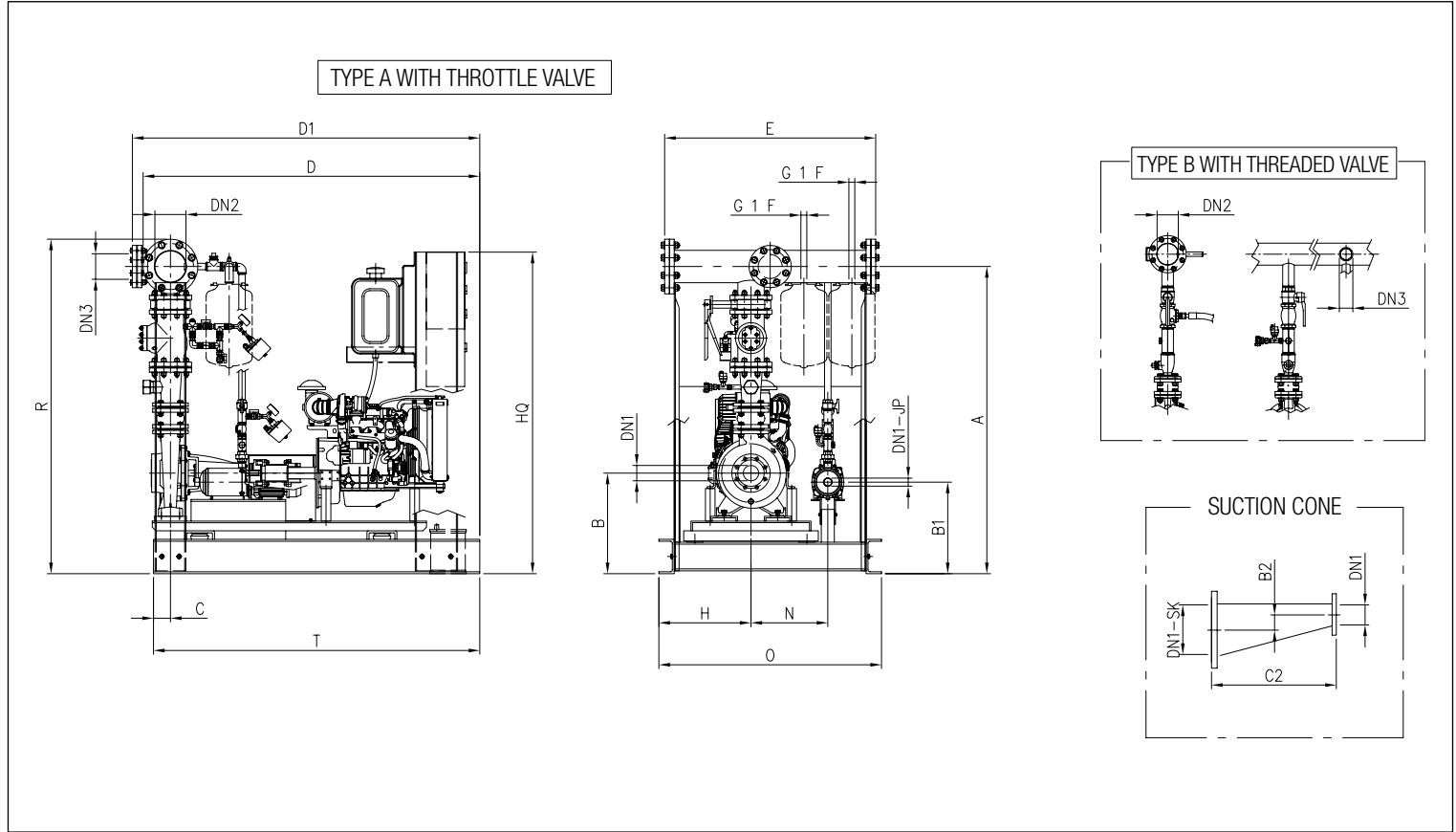

### DIMENSIONS CHART

Model	Pilot pump	Type	Dimensions [mm]																						
			A	B	B1	C	D	D1	E	H	N	DN1	DN1-JP	DN2	DN3	R	HQ	O	T	DN1-SK [1] [2]	B2 [1] [2]	C2 [1] [2]			
FFBD11 3PFS32-160-166/4.6D+0.75P	COMPACT A/10	B	983	365	~364	65	1228	1203	890	315	310	50	G 1	65	G1½	1076	1505	910	1200	65	80	8	14	180	185
FFBD11 3PFS32-200-186/4.6D+0.75P	COMPACT A/10	B	1003	365	~364	65	1228	1203	890	315	310	50	G 1	65	G1½	1096	1505	910	1200	65	80	8	14	180	185
FFBD11 3PFS32-200-200/6.7D+0.9P	COMPACT A/12	B	1003	365	~364	65	1228	1203	890	315	310	50	G 1	65	G1½	1096	1505	910	1200	65	80	8	14	180	185
FFBD11 3PFS32-200-224/7.8D+1.1P	COMPACT A/15	B	1003	365	~364	65	1228	1203	890	315	310	50	G 1	65	G1½	1096	1505	910	1200	65	80	8	14	180	185
FFBD11 3PFS40-160-166/6.7D+0.75P	COMPACT A/10	B	1044	365	~364	65	1235	1214	894	315	310	65	G 1	80	G 2	1144	1505	910	1200	100	100	19	19	197	197
FFBD11 3PFS40-200-183/7.8D+0.75P	COMPACT A/10	B	1064	365	~364	65	1235	1214	894	315	310	65	G 1	80	G 2	1164	1505	910	1200	100	100	19	19	197	197
FFBD11 3PFS40-200-224/14.9D+1.1P	COMPACT A/15	B	1089	390	~364	65	1235	1214	894	315	310	65	G 1	80	G 2	1189	1505	910	1200	100	100	19	19	197	197
FFBD11 3PFS50-160-154/7.8D+0.75P	COMPACT A/10	B	1162	365	~364	65	1245	1232	898	315	310	65	G 1	100	G 2½	1272	1505	910	1200	100	125	19	32	197	227
FFBD11 3PFS50-200-212/14.9D+0.9P	COMPACT A/12	B	1207	390	~364	65	1245	1232	898	315	310	65	G 1	100	G 2½	1317	1505	910	1200	100	125	19	32	197	227
FFBD11 3PFS50-200-224/18.8D+1.1P	COMPACT A/15	B	1234	417	~384	65	1445	1432	998	370	340	65	G 1	100	G 2½	1344	1517	1020	1400	100	125	19	32	197	227
FFBD11 3PFS65-200-190/18.8D+0.9P	COMPACT A/12	A	1398	417	~384	65	1460	1485	1002	370	340	80	G 1	125	DN80	1523	1517	1020	1400	150	200	40	65	340	550
FFBD11 3PFS65-200-212/28.6D+1.1P	COMPACT A/15	A	1432	451	~384	65	1460	1485	1002	370	340	80	G 1	125	DN80	1557	1517	1020	1400	150	200	40	65	340	550
FFBD11 ENRS32-250-255/14.9D+2.2P	MATRIX 5-9T/2.2	B	1073	390	~330	65	1228	1203	890	315	310	50	G 1¼	65	G 1½	1166	1505	910	1200	65	80	8	14	180	185
FFBD11 ENRS40-250-239/14.9D+2.2P	MATRIX 5-9T/2.2	B	1134	390	~330	65	1235	1214	894	315	310	65	G 1¼	80	G 2	1234	1505	910	1200	100	100	19	19	197	197
FFBD11 ENRS40-250-252/18.8D+2.2P	MATRIX 5-9T/2.2	B	1161	417	~350	65	1435	1414	994	370	340	65	G 1¼	80	G 2	1261	1517	1020	1400	100	100	19	19	197	197
FFBD11 ENRS50-250-222/18.8D+2.2P	MATRIX 5-9T/2.2	B	1259	417	~350	65	1445	1432	994	370	340	65	G 1¼	100	G 2½	1369	1517	1020	1400	100	125	19	32	197	227
FFBD11 ENRS50-250-252/28.6D+2.2P	MATRIX 5-9T/2.2	B	1293	451	~350	65	1445	1432	998	370	340	65	G 1¼	100	G 2½	1403	1517	1020	1400	100	125	19	32	197	227
FFBD11 ENRS65-250-226/28.6D+2.2P	MATRIX 5-9T/2.2	A	1457	451	~350	65	1460	1485	1002	370	340	80	G 1¼	125	DN80	1582	1517	1020	1400	150	200	40	65	340	550
FFBD11 ENRS80-200-199/28.6D+2.2P	AGA 300T SUR	A	1551	451	~430	65	1478	1501	1002	370	340	100	G 1½	150	DN100	1694	1517	1020	1400	200	250	52	80	450	650
FFBD11 ENRS100-200-190/28.6D+2.2P	AGA 300T SUR	A	1699	451	~430	65	1505	1529	1006	370	340	125	G 1½	200	DN125	1869	1517	1020	1400	250	250	67	67	550	550

[1]= Underhead  
[2]= Overhead

The contents of the publication should not be regarded as binding. EBARA Pump Europe S.p.A. reserves the right to effect any modification, without prior notice.

## FFBD11 FIRE-FIGHTING UNITS

### FFBD11 DIMENSIONS - ENRS MOTOR PUMP+PILOT

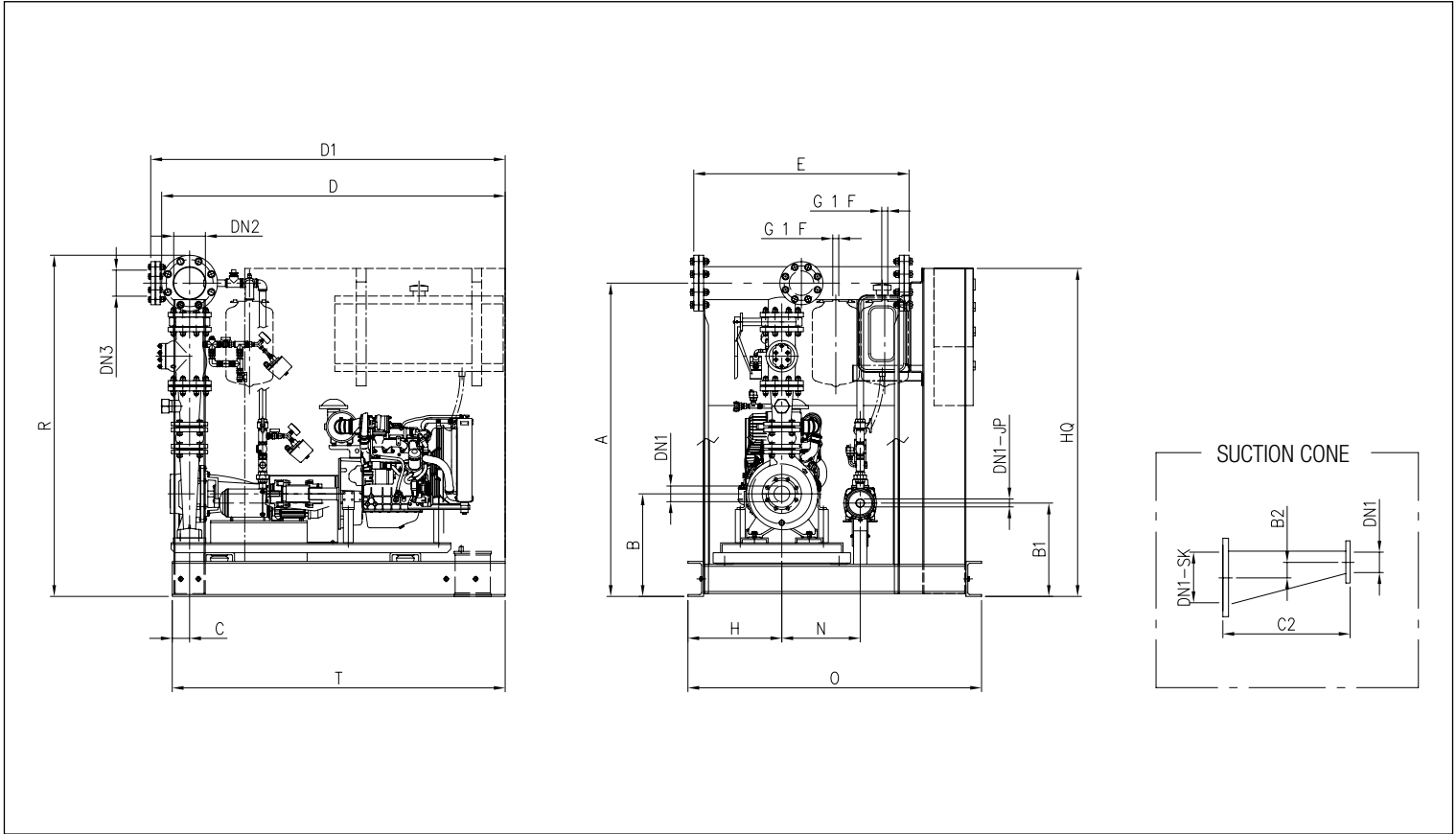

### DIMENSIONS CHART

Model	Pilot pump	Dimensions [mm]																						
		A	B	B1	C	D	D1	E	H	N	DN1	DN1-JP	DN2	DN3	R	HQ	O	T	DN1-SK [1] [2]	B2 [1] [2]	C2 [1] [2]			
FFBD11 ENRS65-250-237/35D+2.2P	MATRIX 5-9T/2.2	1526	520	~480	125	1700	1725	1697	450	430	80	G 1 ¼	125	DN80	1651	1830	1760	1700	150	200	40	65	340	550
FFBD11 ENRS65-250-252/53D+2.2P	MATRIX 5-9T/2.2	1526	520	~480	125	1700	1725	1697	450	430	80	G 1 ¼	125	DN80	1651	1830	1760	1700	150	200	40	65	340	550
FFBD11 ENRS80-200-207/35D+2.2P	AGA 300T SUR	1620	520	~560	125	1718	1741	1697	450	430	100	G 1 ½	150	DN100	1763	1830	1760	1700	200	250	80	80	720	650
FFBD11 ENRS80-200-214/53D+2.2P	AGA 300T SUR	1620	520	~560	125	1718	1741	1697	450	430	100	G 1 ½	150	DN100	1763	1830	1760	1700	200	250	80	80	720	650
FFBD11 ENRS80-250-222/35D+2.2P	MATRIX 5-9T/2.2	1650	520	~480	125	1718	1741	1697	450	430	100	G 1 ¼	150	DN100	1793	1830	1760	1700	200	200	52	52	450	450
FFBD11 ENRS80-250-243/53D+2.2P	MATRIX 5-9T/2.2	1650	520	~480	125	1718	1741	1697	450	430	100	G 1 ¼	150	DN100	1793	1830	1760	1700	200	200	52	52	450	450
FFBD11 ENRS80-250-255/73,5D+2.2P	MATRIX 5-9T/2.2	1700	570	~480	125	1718	1741	1697	450	430	100	G 1 ¼	150	DN100	1843	1830	1760	1700	200	200	52	52	450	450
FFBD11 ENRS100-200-197/35D+2.2P	AGA 300T SUR	1768	520	~560	125	1745	1769	1701	450	430	125	G 1 ½	200	DN125	1938	1830	1760	1700	250	250	67	67	620	620
FFBD11 ENRS100-200-213/53D+2.2P	AGA 300T SUR	1768	520	~560	125	1745	1769	1701	450	430	125	G 1 ½	200	DN125	1938	1830	1760	1700	250	250	67	67	620	620
FFBD11 ENRS100-250-225/53D+2.2P	MATRIX 5-9T/2.2	1768	520	~480	125	1745	1769	1701	450	430	125	G 1 ¼	200	DN125	1938	1830	1760	1700	250	250	67	67	620	620
FFBD11 ENRS100-250-242/73,5D+2.2P	MATRIX 5-9T/2.2	1788	540	~480	125	1745	1769	1701	450	430	125	G 1 ¼	200	DN125	1958	1830	1760	1700	250	250	67	67	620	620
FFBD11 ENRS100-250-255/110D+2.2P	MATRIX 5-9T/2.2	1848	600	~480	125	2045	2069	1701	450	430	125	G 1 ¼	200	DN125	2018	1830	1760	2000	250	250	67	67	620	620

[1]= Underhead  
[2]= Overhead

### FFBD21 DIMENSIONS - 3PFS-ENRS MOTOR PUMPS+PILOT

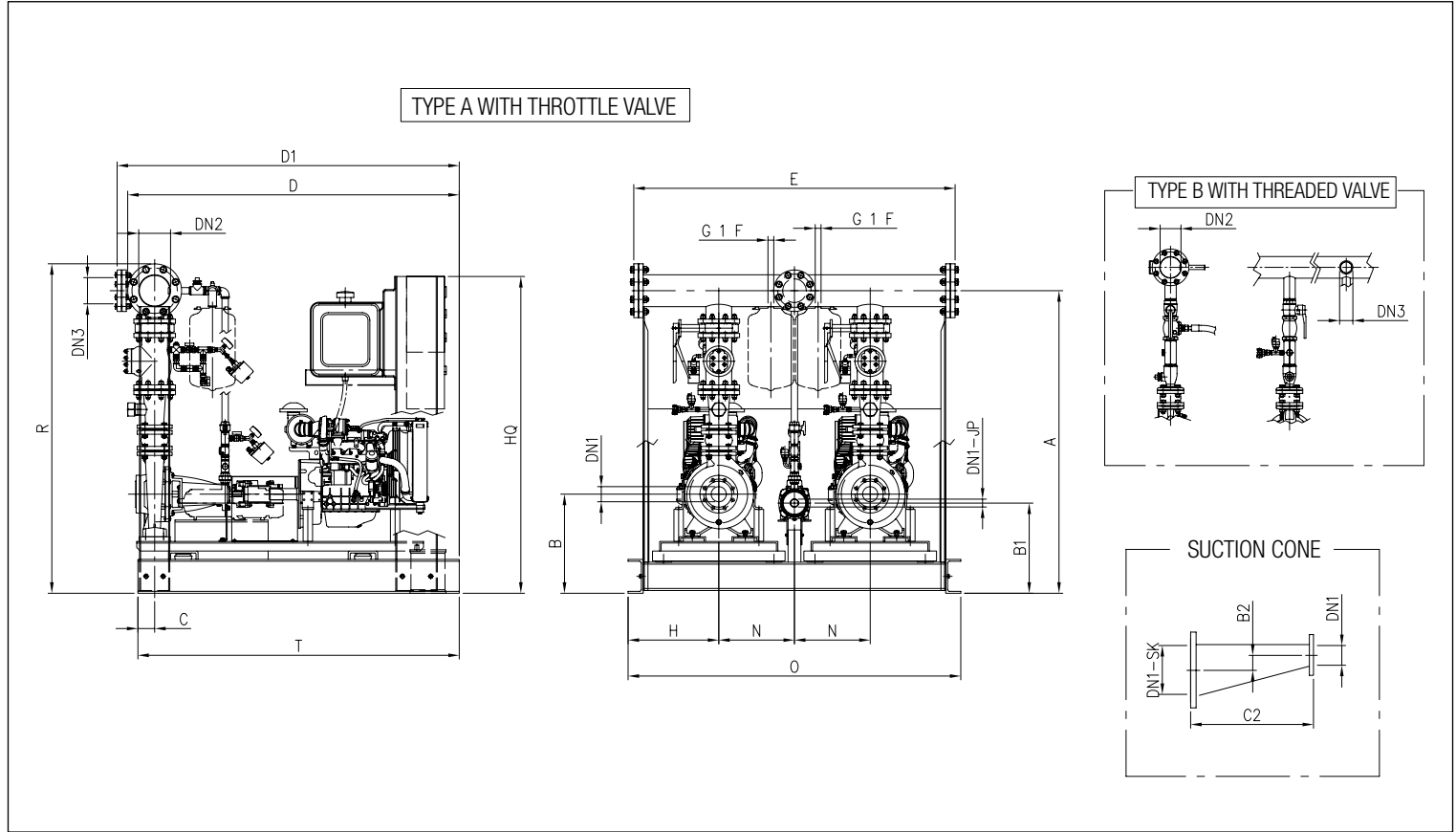

### DIMENSIONS CHART

Model	Pilot pump	Type	Dimensions [mm]																						
			A	B	B1	C	D	D1	E	H	N	DN1	DN1-JP	DN2	DN3	R	HQ	O	T	DN1-SK [1] [2]	B2 [1] [2]	C2 [1] [2]			
FFBD21 3PFS32-160-166/4.6D+0.75P	COMPACT A/10	B	983	365	~364	65	1228	1203	1230	315	310	50	G 1	65	G1½	1076	1505	1250	1200	65	80	8	14	180	185
FFBD21 3PFS32-200-186/4.6D+0.75P	COMPACT A/10	B	1003	365	~364	65	1228	1203	1230	315	310	50	G 1	65	G1½	1096	1505	1250	1200	65	80	8	14	180	185
FFBD21 3PFS32-200-200/6.7D+0.9P	COMPACT A/12	B	1003	365	~364	65	1228	1203	1230	315	310	50	G 1	65	G1½	1096	1505	1250	1200	65	80	8	14	180	185
FFBD21 3PFS32-200-224/7.8D+1.1P	COMPACT A/15	B	1003	365	~364	65	1228	1203	1230	315	310	50	G 1	65	G1½	1096	1505	1250	1200	65	80	8	14	180	185
FFBD21 3PFS40-160-166/6.7D+0.75P	COMPACT A/10	B	1044	365	~364	65	1235	1214	1234	315	310	65	G 1	80	G 2	1144	1505	1250	1200	100	100	19	19	197	197
FFBD21 3PFS40-200-183/7.8D+0.75P	COMPACT A/10	B	1064	365	~364	65	1235	1214	1234	315	310	65	G 1	80	G 2	1164	1505	1250	1200	100	100	19	19	197	197
FFBD21 3PFS40-200-224/14.9D+1.1P	COMPACT A/15	B	1089	390	~364	65	1235	1214	1234	315	310	65	G 1	80	G 2	1189	1505	1250	1200	100	100	19	19	197	197
FFBD21 3PFS50-160-154/7.8D+0.75P	COMPACT A/10	B	1162	365	~364	65	1245	1232	1238	315	310	65	G 1	100	G 2½	1272	1505	1250	1200	100	125	19	32	197	227
FFBD21 3PFS50-200-212/14.9D+0.9P	COMPACT A/12	B	1207	390	~364	65	1245	1232	1238	315	310	65	G 1	100	G 2½	1317	1505	1250	1200	100	125	19	32	197	227
FFBD21 3PFS50-200-224/18.8D+1.1P	COMPACT A/15	B	1234	417	~384	65	1445	1432	1403	370	340	65	G 1	100	G 2½	1344	1517	1420	1400	100	125	19	32	197	227
FFBD21 3PFS65-200-190/18.8D+0.9P	COMPACT A/12	A	1398	417	~384	65	1460	1485	1407	370	340	80	G 1	125	DN80	1523	1517	1420	1400	150	200	40	65	340	550
FFBD21 3PFS65-200-212/28.6D+1.1P	COMPACT A/15	A	1432	451	~384	65	1460	1485	1407	370	340	80	G 1	125	DN80	1557	1517	1420	1400	150	200	40	65	340	550
FFBD21 ENRS32-250-255/14.9D+2.2P	MATRIX 5-9T/2.2	B	1073	390	~330	65	1228	1203	1230	315	310	50	G 1¼	65	G1½	1166	1505	1250	1200	65	80	8	14	180	185
FFBD21 ENRS40-250-239/14.9D+2.2P	MATRIX 5-9T/2.2	B	1129	385	~330	65	1235	1214	1234	315	310	65	G 1¼	80	G 2	1229	1505	1250	1200	100	100	19	19	197	197
FFBD21 ENRS40-250-252/18.8D+2.2P	MATRIX 5-9T/2.2	B	1161	417	~350	65	1435	1414	1399	370	340	65	G 1¼	80	G 2	1261	1517	1420	1400	100	100	19	19	197	197
FFBD21 ENRS50-250-222/18.8D+2.2P	MATRIX 5-9T/2.2	B	1259	417	~350	65	1445	1432	1403	370	340	65	G 1¼	100	G 2½	1369	1517	1420	1400	100	125	19	32	197	227
FFBD21 ENRS50-250-252/28.6D+2.2P	MATRIX 5-9T/2.2	B	1293	451	~350	65	1445	1432	1403	370	340	65	G 1¼	100	G 2½	1403	1517	1420	1400	100	125	19	32	197	227
FFBD21 ENRS65-250-226/28.6D+2.2P	MATRIX 5-9T/2.2	A	1457	451	~350	65	1460	1485	1407	370	340	80	G 1¼	125	DN80	1582	1517	1420	1400	150	200	40	65	340	550
FFBD21 ENRS80-200-199/28.6D+2.2P	AGA 300T SUR	A	1551	451	~430	65	1478	1501	1407	370	340	100	G 1½	150	DN100	1694	1517	1420	1400	200	250	52	80	450	650
FFBD21 ENRS100-200-190/28.6D+2.2P	AGA 300T SUR	A	1699	451	~430	65	1505	1529	1407	370	340	125	G 1½	200	DN125	1869	1517	1420	1400	250	250	67	67	550	550

[1]= Underhead  
[2]= Overhead

The contents of this publication should not be regarded as binding. EBARA Pumps Europe S.p.A. reserves the right to effect any modification it deems necessary, without prior notice.

## FFBD21 FIRE-FIGHTING UNITS

### FFBD21 DIMENSIONS - ENRS MOTOR PUMPS+PILOT

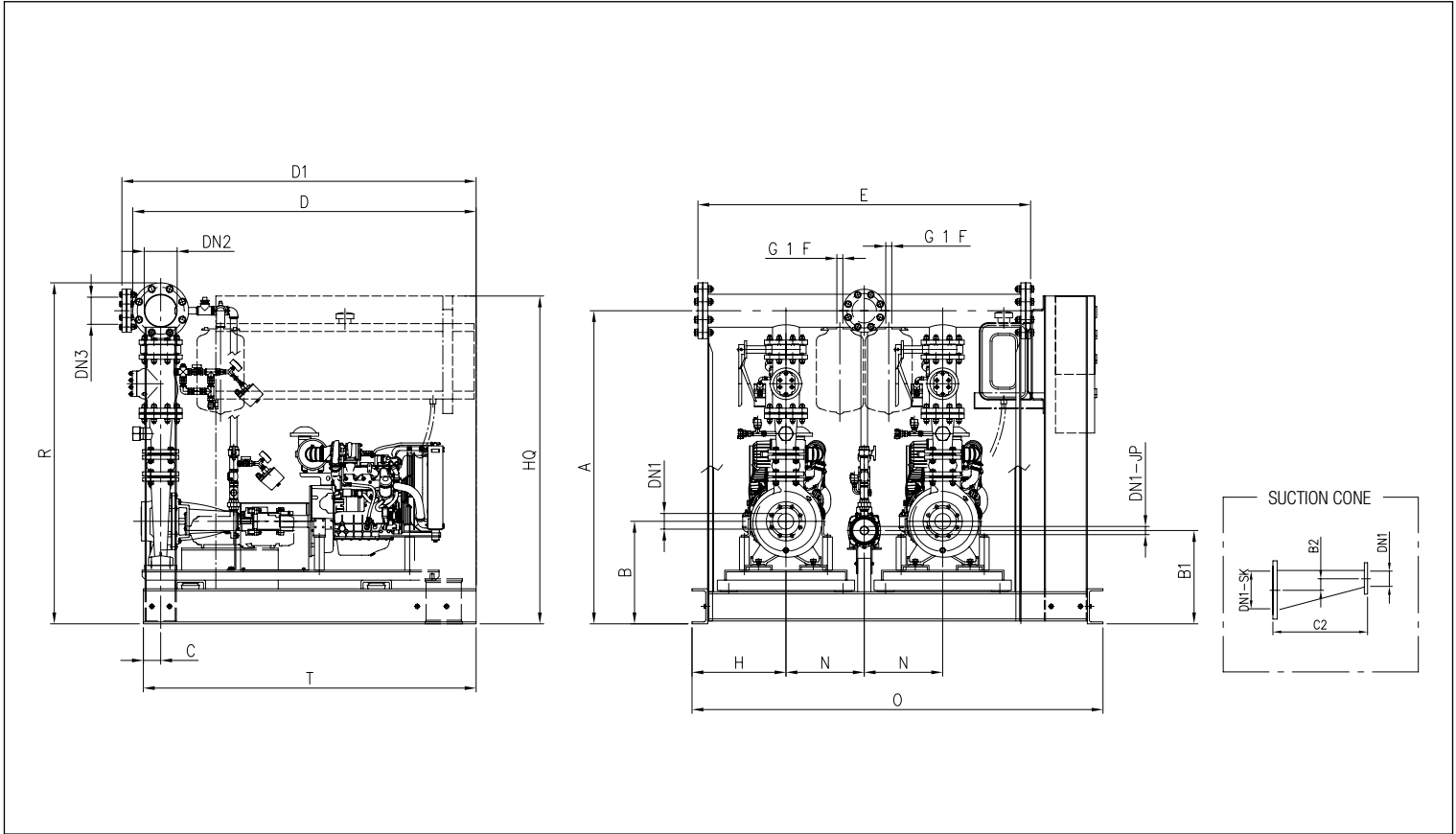

### DIMENSIONS CHART

Model	Pilot pump	Dimensions [mm]																						
		A	B	B1	C	D	D1	E	H	N	DN1	DN1-JP	DN2	DN3	R	HQ	O	T	DN1-SK [1] [2]	B2 [1] [2]	C2 [1] [2]			
FFBD21 ENRS65-250-237/35D+2.2P	MATRIX 5-9T/2.2	1556	550	~480	125	1700	1725	2037	450	430	80	G 1 ¼	125	DN80	1681	1830	2100	1700	150	200	40	65	340	550
FFBD21 ENRS65-250-252/53D+2.2P	MATRIX 5-9T/2.2	1556	550	~480	125	1700	1725	2037	450	430	80	G 1 ¼	125	DN80	1681	1830	2100	1700	150	200	40	65	340	550
FFBD21 ENRS80-200-207/35D+2.2P	AGA 300T SUR	1650	550	~560	125	1718	1741	2037	450	430	100	G 1 ½	150	DN100	1793	1830	2100	1700	200	250	52	80	450	650
FFBD21 ENRS80-200-214/53D+2.2P	AGA 300T SUR	1650	550	~560	125	1718	1741	2037	450	430	100	G 1 ½	150	DN100	1793	1830	2100	1700	200	250	52	80	450	650
FFBD21 ENRS80-250-222/35D+2.2P	MATRIX 5-9T/2.2	1680	550	~480	125	1718	1741	2037	450	430	100	G 1 ¼	150	DN100	1823	1830	2100	1700	200	200	52	52	450	450
FFBD21 ENRS80-250-243/53D+2.2P	MATRIX 5-9T/2.2	1680	550	~480	125	1718	1741	2037	450	430	100	G 1 ¼	150	DN100	1823	1830	2100	1700	200	200	52	52	450	450
FFBD21 ENRS80-250-255/73,5D+2.2P	MATRIX 5-9T/2.2	1730	600	~480	125	1718	1741	2037	450	430	100	G 1 ¼	150	DN100	1873	1830	2100	1700	200	200	52	52	450	450
FFBD21 ENRS100-200-197/35D+2.2P	AGA 300T SUR	1798	550	~560	125	1745	1769	2041	450	430	125	G 1 ½	200	DN125	1968	1830	2100	1700	250	250	67	67	550	550
FFBD21 ENRS100-200-213/53D+2.2P	AGA 300T SUR	1798	550	~560	125	1745	1769	2041	450	430	125	G 1 ½	200	DN125	1968	1830	2100	1700	250	250	67	67	550	550
FFBD21 ENRS100-250-225/53D+2.2P	MATRIX 5-9T/2.2	1798	550	~480	125	1745	1769	2041	450	430	125	G 1 ¼	200	DN125	1968	1830	2100	1700	250	250	67	67	550	550
FFBD21 ENRS100-250-242/73,5D+2.2P	MATRIX 5-9T/2.2	1818	570	~480	125	1745	1769	2041	450	430	125	G 1 ¼	200	DN125	1988	1830	2100	1700	250	250	67	67	550	550
FFBD21 ENRS100-250-255/110D+2.2P	MATRIX 5-9T/2.2	1848	600	~480	125	2045	2069	2041	450	430	125	G 1 ¼	200	DN125	2018	1830	2100	2000	250	250	67	67	550	550

[1]= Underhead  
[2]= Overhead

## FFBD111 FIRE-FIGHTING UNITS

TABLE OF BASE-JOINT ELECTRICAL-DIESEL MODELS

Pump	Size diameter impeller	Motor electric [kW]	Motor diesel [kW]	FFBD111	Pump pilot
3PF	32-160-166	3	4,6	FFBD111 3PFS 32-160-166/3/4.6	COMPACT A/10
3PF	32-200-186	4	4,6	FFBD111 3PFS 32-200-186/4/4.6	COMPACT A/10
3PF	32-200-200	5,5	6,8	FFBD111 3PFS 32-200-200/5.5/6.8	COMPACT A/12
3PF	32-200-224	7,5	7,8	FFBD111 3PFS 32-200-224/7.5/7.8	COMPACT A/15
ENR	32-250-245	11	14,9	FFBD111 ENRS 32-250-245/11/14.9	MATRIX 5-9T/2.2
ENR	32-250-255	15	14,9	FFBD111 ENRS 32-250-255/15/14.9	MATRIX 5-9T/2.2
3PF	40-160-166	5,5	6,8	FFBD111 3PFS 40-160-166/5.5/6.8	COMPACT A/10
3PF	40-200-183	7,5	7,8	FFBD111 3PFS 40-200-183/7.5/7.8	COMPACT A/10
3PF	40-200-200	9,2	14,9	FFBD111 3PFS 40-200-200/11/14.9	COMPACT A/12
3PF	40-200-224	15	14,9	FFBD111 3PFS 40-200-224/15/14.9	COMPACT A/15
ENR	40-250-239	15	14,9	FFBD111 ENRS 40-250-239/15/14.9	MATRIX 5-9T/2.2
ENR	40-250-252	18,5	18,8	FFBD111 ENRS 40-250-252/18.5/18.8	MATRIX 5-9T/2.2
3PF	50-160-154	7,5	7,8	FFBD111 3PFS 50-160-154/7.5/7.8	COMPACT A/10
3PF	50-200-197	11	14,9	FFBD111 3PFS 50-200-197/11/14.9	COMPACT A/12
3PF	50-200-212	15	14,9	FFBD111 3PFS 50-200-212/15/14.9	COMPACT A/12
3PF	50-200-224	18,5	18,8	FFBD111 3PFS 50-200-224/18.5/18.8	COMPACT A/15
ENR	50-250-222	18,5	18,8	FFBD111 ENRS 50-250-222/18.5/18.8	MATRIX 5-9T/2.2
ENR	50-250-235	22	28,6	FFBD111 ENRS 50-250-235/22/28.6	MATRIX 5-9T/2.2
ENR	50-250-252	30	28,6	FFBD111 ENRS 50-250-252/30/28.6	MATRIX 5-9T/2.2
3PF	65-200-190	15	18,8	FFBD111 3PFS 65-200-190/15/18.8	COMPACT A/12
3PF	65-200-208	22	28,6	FFBD111 3PFS 65-200-208/22/28.6	COMPACT A/15
3PF	65-200-212	30	28,6	FFBD111 3PFS 65-200-212/30/28.6	COMPACT A/15
ENR	65-250-226	30	28,6	FFBD111 ENRS 65-250-226/30/28.6	MATRIX 5-9T/2.2
ENR	65-250-237	37	35	FFBD111 ENRS 65-250-237/37/35	MATRIX 5-9T/2.2
ENR	65-250-252	45	53	FFBD111 ENRS 65-250-252/45/53	MATRIX 5-9T/2.2
ENR	80-200-190	22	28,6	FFBD111 ENRS 80-200-190/22/28.6	AGA 300T SUR
ENR	80-200-199	30	28,6	FFBD111 ENRS 80-200-199/30/28.6	AGA 300T SUR
ENR	80-200-207	37	35	FFBD111 ENRS 80-200-207/37/35	AGA 300T SUR
ENR	80-200-214	45	53	FFBD111 ENRS 80-200-214/45/53	AGA 300T SUR
ENR	80-250-222	37	35	FFBD111 ENRS 80-250-222/37/35	MATRIX 5-9T/2.2
ENR	80-250-234	45	53	FFBD111 ENRS 80-250-234/45/53	MATRIX 5-9T/2.2
ENR	80-250-243	55	53	FFBD111 ENRS 80-250-243/55/53	MATRIX 5-9T/2.2
ENR	80-250-255	75	73,5	FFBD111 ENRS 80-250-255/75/73.5	MATRIX 5-9T/2.2
ENR	100-200-182	22	28,6	FFBD111 ENRS 100-200-182/22/28.6	AGA 300T SUR
ENR	100-200-190	30	28,6	FFBD111 ENRS 100-200-190/30/28.6	AGA 300T SUR
ENR	100-200-194	30	35	FFBD111 ENRS 100-200-194/30/35	AGA 300T SUR
ENR	100-200-197	37	35	FFBD111 ENRS 100-200-197/37/35	AGA 300T SUR
ENR	100-200-209	45	53	FFBD111 ENRS 100-200-209/45/53	AGA 300T SUR
ENR	100-200-213	55	53	FFBD111 ENRS 100-200-213/55/53	AGA 300T SUR
ENR	100-250-221	45	53	FFBD111 ENRS 100-250-221/45/53	MATRIX 5-9T/2.2
ENR	100-250-225	55	53	FFBD111 ENRS 100-250-225/55/53	MATRIX 5-9T/2.2
ENR	100-250-232	55	73,5	FFBD111 ENRS 100-250-232/55/73.5	MATRIX 5-9T/2.2
ENR	100-250-242	75	73,5	FFBD111 ENRS 100-250-242/75/73.5	MATRIX 5-9T/2.2
ENR	100-250-255	90	110	FFBD111 ENRS 100-250-255/90/110	MATRIX 5-9T/2.2

For performance data refer to pages 14 to 32.

## FFBD111 FIRE-FIGHTING UNITS

### FFBD111 DIMENSIONS - 3PFS-ENRS ELECTRICAL PUMP-MOTOR PUMP+PILOT

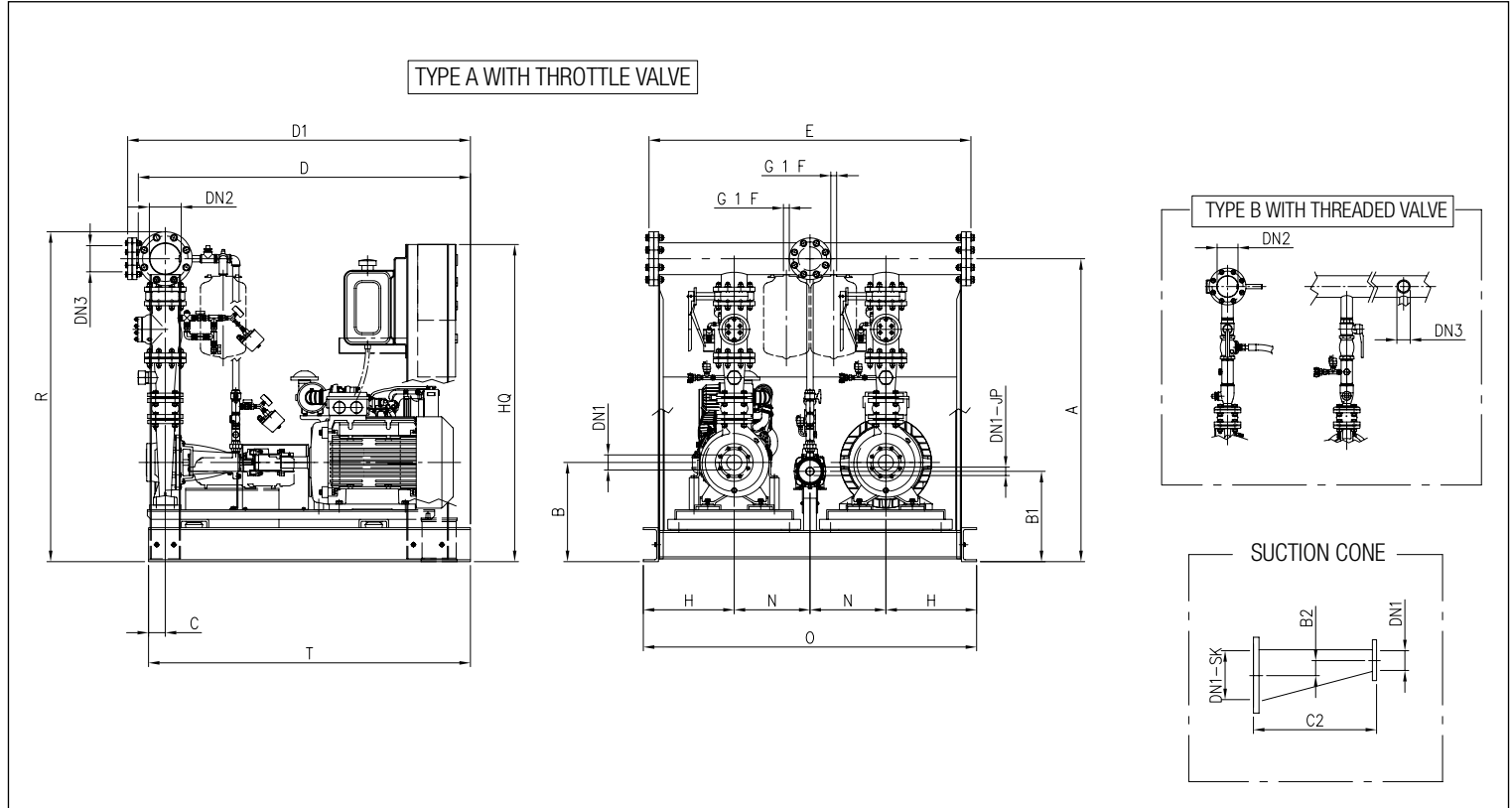

### DIMENSIONS CHART

Model	Pilot pump	Type	Dimensions [mm]																						
			A	B	B1	C	D	D1	E	H	N	DN1	DN1-JP	DN2	DN3	R	HQ	O	T	DN1-SK [1]	[2]	B2 [1]	[2]	C2 [1]	[2]
FFBD111 3PFS32-160-166/3E/4.6D+0.75P	COMPACT A/10	B	983	365	~364	65	1228	1203	1230	315	310	50	G 1	65	G1½	1076	1505	1250	1200	65	80	8	14	180	185
FFBD111 3PFS32-200-186/4E/4.6D+0.75P	COMPACT A/10	B	1003	365	~364	65	1228	1203	1230	315	310	50	G 1	65	G1½	1096	1505	1250	1200	65	80	8	14	180	185
FFBD111 3PFS32-200-200/5.5E/6.7D+0.9P	COMPACT A/12	B	1003	365	~364	65	1228	1203	1230	315	310	50	G 1	65	G1½	1096	1505	1250	1200	65	80	8	14	180	185
FFBD111 3PFS32-200-224/7.5E/7.8D+1.1P	COMPACT A/15	B	1003	365	~364	65	1228	1203	1230	315	310	50	G 1	65	G1½	1096	1505	1250	1200	65	80	8	14	180	185
FFBD111 3PFS40-160-166/5.5E/6.7D+0.75P	COMPACT A/10	B	1044	365	~364	65	1235	1214	1234	315	310	65	G 1	80	G 2	1144	1505	1250	1200	100	100	19	19	197	197
FFBD111 3PFS40-200-183/7.5E/7.8D+0.75P	COMPACT A/10	B	1064	365	~364	65	1235	1214	1234	315	310	65	G 1	80	G 2	1164	1505	1250	1200	100	100	19	19	197	197
FFBD111 3PFS40-200-200/9.2E/14.9D+0.9P	COMPACT A/12	B	1089	390	~364	65	1235	1214	1234	315	310	65	G 1	80	G 2	1189	1505	1250	1200	100	100	19	19	197	197
FFBD111 3PFS40-200-224/15E/14.9D+1.1P	COMPACT A/15	B	1089	390	~364	65	1235	1214	1234	315	310	65	G 1	80	G 2	1189	1505	1250	1200	100	100	19	19	197	197
FFBD111 3PFS50-160-154/7.5E/7.8D+0.75P	COMPACT A/10	B	1162	365	~364	65	1245	1232	1238	315	310	65	G 1	100	G 2½	1272	1505	1250	1200	100	125	19	32	197	227
FFBD111 3PFS50-200-197/11E/14.9D+0.9P	COMPACT A/12	B	1207	390	~364	65	1245	1232	1238	315	310	65	G 1	100	G 2½	1317	1505	1250	1200	100	125	19	32	197	227
FFBD111 3PFS50-200-212/15E/14.9D+0.9P	COMPACT A/12	B	1207	390	~364	65	1245	1232	1238	315	310	65	G 1	100	G 2½	1317	1505	1250	1200	100	125	19	32	197	227
FFBD111 3PFS50-200-224/18.5E/18.8D+1.1P	COMPACT A/15	B	1234	417	~384	65	1445	1432	1403	370	340	65	G 1	100	G 2½	1344	1517	1420	1400	100	125	19	32	197	227
FFBD111 3PFS65-200-190/15E/18.8D+0.9P	COMPACT A/12	A	1398	417	~384	65	1460	1485	1407	370	340	80	G 1	125	DN80	1523	1517	1420	1400	150	200	40	65	340	550
FFBD111 3PFS65-200-208/22E/28.6D+1.1P	COMPACT A/15	A	1432	451	~384	65	1460	1485	1407	370	340	80	G 1	125	DN80	1557	1517	1420	1400	150	200	40	65	340	550
FFBD111 3PFS65-200-212/30E/28.6D+1.1P	COMPACT A/15	A	1432	451	~384	65	1460	1485	1407	370	340	80	G 1	125	DN80	1557	1517	1420	1400	150	200	40	65	340	550
FFBD111 ENRS32-250-245/11E/14.9D+2.2P	MATRIX 5-9T/2.2	B	1073	390	~330	65	1228	1203	1230	315	310	50	G1¼	65	G 2½	1166	1505	1250	1200	65	80	8	14	180	185
FFBD111 ENRS32-250-255/15E/14.9D+2.2P	MATRIX 5-9T/2.2	B	1073	390	~330	65	1228	1203	1230	315	310	50	G1¼	65	G 2½	1166	1505	1250	1200	65	80	8	14	180	185
FFBD111 ENRS40-250-239/15E/14.9D+2.2P	MATRIX 5-9T/2.2	B	1129	385	~330	65	1235	1214	1234	315	310	65	G1¼	80	G2	1229	1132	1250	1200	100	100	19	19	197	197
FFBD111 ENRS40-250-252/18.5E/18.8D+2.2P	MATRIX 5-9T/2.2	B	1161	417	~350	65	1435	1414	1399	370	340	65	G1¼	80	G2	1261	1159	1420	1400	100	100	19	19	197	197
FFBD111 ENRS50-250-222/18.5E/18.8D+2.2P	MATRIX 5-9T/2.2	B	1259	417	~350	65	1445	1432	1403	370	340	65	G1¼	100	G 2½	1369	1517	1420	1400	100	125	19	32	197	227
FFBD111 ENRS50-250-235/22E/28.6D+2.2P	MATRIX 5-9T/2.2	B	1293	451	~350	65	1445	1432	1403	370	340	65	G1¼	100	G 2½	1403	1517	1420	1400	100	125	19	32	197	227
FFBD111 ENRS50-250-252/30E/28.6D+2.2P	MATRIX 5-9T/2.2	B	1293	451	~350	65	1445	1432	1403	370	340	65	G1¼	100	G 2½	1403	1517	1420	1400	100	125	19	32	197	227
FFBD111 ENRS65-250-226/30E/28.6D+2.2P	MATRIX 5-9T/2.2	A	1457	451	~350	65	1460	1485	1407	370	340	80	G1¼	125	DN80	1582	1517	1420	1400	150	200	40	65	340	550
FFBD111 ENRS80-200-190/22E/28.6D+2.2P	AGA 300T SUR	A	1551	451	~430	65	1478	1501	1407	370	340	100	G1½	150	DN100	1694	1517	1420	1400	200	250	52	80	450	650
FFBD111 ENRS80-200-199/30E/28.6D+2.2P	AGA 300T SUR	A	1551	451	~430	65	1478	1501	1407	370	340	100	G1½	150	DN100	1694	1517	1420	1400	200	250	52	80	450	650
FFBD111 ENRS100-200-182/22E/28.6D+2.2P	AGA 300T SUR	A	1699	451	~430	65	1505	1529	1411	370	340	125	G1½	200	DN125	1869	1517	1420	1400	250	250	67	67	550	550
FFBD111 ENRS100-200-190/30E/28.6D+2.2P	AGA 300T SUR	A	1699	451	~430	65	1505	1529	1411	370	340	125	G1½	200	DN125	1869	1517	1420	1400	250	250	67	67	550	550

[1]= Underhead  
[2]= Overhead

## FFBD111 FIRE-FIGHTING UNITS

### FFBD111 DIMENSIONS - ENRS ELECTRICAL PUMP-MOTOR PUMP+PILOT

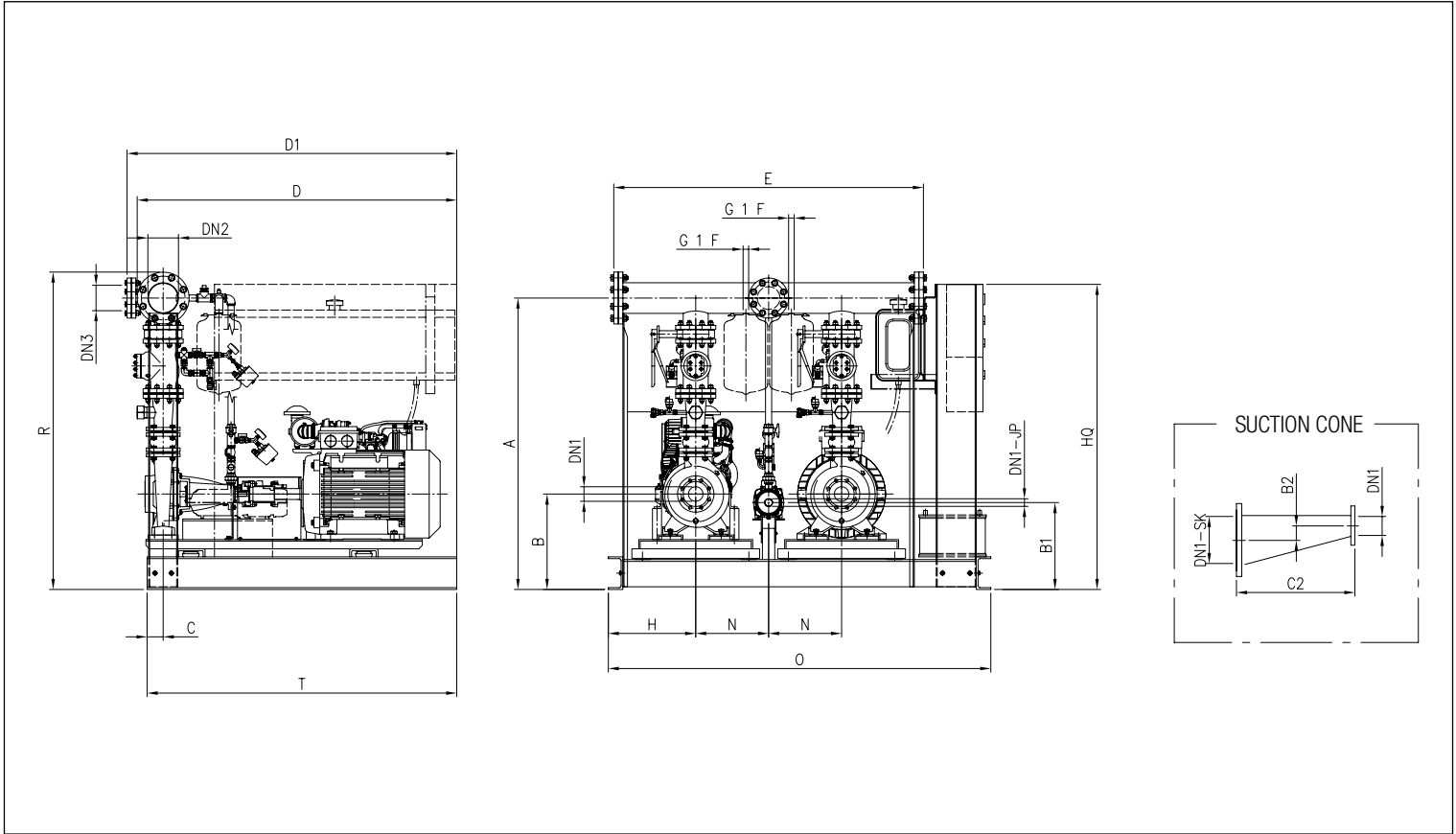

### DIMENSIONS CHART

Model	Pilot pump	Dimensions [mm]																						
		A	B	B1~	C	D	D1	E	H	N	DN1	DN1-JP	DN2	DN3	R	HQ	O	T	DN1-SK [1] [2]	B2 [1] [2]	C2 [1] [2]			
FFBD111 ENRS65-250-237/37E/35D+2.2P	MATRIX 5-9T/2.2	1556	550	480	125	1700	1725	2037	450	430	80	G1¼	125	DN80	1681	1830	2100	1700	150	200	40	65	340	550
FFBD111 ENRS65-250-252/45E/53D+2.2P	MATRIX 5-9T/2.2	1556	550	480	125	1700	1725	2037	450	430	80	G1¼	125	DN80	1681	1830	2100	1700	150	200	40	65	340	550
FFBD111 ENRS80-200-207/37E/35D+2.2P	AGA 300T SUR	1650	550	560	125	1718	1741	2037	450	430	100	G1½	150	DN100	1793	1830	2100	1700	200	250	52	80	450	650
FFBD111 ENRS80-200-214/45E/53D+2.2P	AGA 300T SUR	1650	550	560	125	1718	1741	2037	450	430	100	G1½	150	DN100	1793	1830	2100	1700	200	250	52	80	450	650
FFBD111 ENRS80-250-222/37E/35D+2.2P	MATRIX 5-9T/2.2	1680	550	480	125	1718	1741	2037	450	430	100	G1¼	150	DN100	1823	1830	2100	1700	200	200	52	52	450	450
FFBD111 ENRS80-250-234/45E/53D+2.2P	MATRIX 5-9T/2.2	1680	550	480	125	1718	1741	2037	450	430	100	G1¼	150	DN100	1823	1830	2100	1700	200	200	52	52	450	450
FFBD111 ENRS80-250-243/55E/53D+2.2P	MATRIX 5-9T/2.2	1700	570	480	125	1718	1741	2037	450	430	100	G1¼	150	DN100	1843	1830	2100	1700	200	200	52	52	450	450
FFBD111 ENRS80-250-255/75E/73.5D+2.2P	MATRIX 5-9T/2.2	1730	600	480	125	1718	1741	2037	450	430	100	G1¼	150	DN100	1873	1830	2100	1700	200	200	52	52	450	450
FFBD111 ENRS100-200-194/30E/35D+2.2P	AGA 300T SUR	1798	550	560	125	1745	1769	2041	450	430	125	G1½	200	DN125	1968	1830	2100	1700	250	250	67	67	550	550
FFBD111 ENRS100-200-197/37E/35D+2.2P	AGA 300T SUR	1798	550	560	125	1745	1769	2041	450	430	125	G1½	200	DN125	1968	1830	2100	1700	250	250	67	67	550	550
FFBD111 ENRS100-200-209/45E/53D+2.2P	AGA 300T SUR	1798	550	560	125	1745	1769	2041	450	430	125	G1½	200	DN125	1968	1830	2100	1700	250	250	67	67	550	550
FFBD111 ENRS100-200-213/55E/53D+2.2P	AGA 300T SUR	1818	570	560	125	1745	1769	2041	450	430	125	G1½	200	DN125	1988	1830	2100	1700	250	250	67	67	550	550
FFBD111 ENRS100-250-221/45E/53D+2.2P	MATRIX 5-9T/2.2	1793	545	480	125	1745	1769	2041	450	430	125	G1¼	200	DN125	1963	1830	2100	1700	250	250	67	67	550	550
FFBD111 ENRS100-250-225/55E/53D+2.2P	MATRIX 5-9T/2.2	1818	570	480	125	1745	1769	2041	450	430	125	G1¼	200	DN125	1988	1830	2100	1700	250	250	67	67	550	550
FFBD111 ENRS100-250-232/55E/73.5D+2.2P	MATRIX 5-9T/2.2	1818	570	480	125	1745	1769	2041	450	430	125	G1¼	200	DN125	1988	1830	2100	1700	250	250	67	67	550	550
FFBD111 ENRS100-250-242/75E/73.5D+2.2P	MATRIX 5-9T/2.2	1848	600	480	125	1745	1769	2041	450	430	125	G1¼	200	DN125	2018	1830	2100	1700	250	250	67	67	550	550
FFBD111 ENRS100-250-255/90E/110D+2.2P	MATRIX 5-9T/2.2	1848	600	480	125	2045	2069	2041	450	430	125	G1¼	200	DN125	2018	1830	2100	2000	250	250	67	67	550	550

[1]= Underhead  
[2]= Overhead

The contents of the publication should not be regarded as binding. EBARA Pumps Europe S.p.A. reserves the right to effect any modification it deems necessary, without prior notice.

## FFS-S FIRE-FIGHTING UNIT KITS

**SUBMERGED PUMP PERFORMANCE TABLE (SF6 - WINNER 4N15)**

Model Three-phase 400V	P <sub>2</sub>		Q=Flow rate						
	[HP]	[kW]	l/min	200	250	300	400	500	550
			m <sup>3</sup> /h	12	15	18	24	30	33
			H=Head [m]						
SF6 S25-3	4	3	40,0	38,0	35,5	29,5	21,5	16,5	
SF6 S25-4	5,5	4	53,0	50,5	47,5	39,5	29,0	22,0	
SF6 S25-6	7,5	5,5	80,0	76,0	71,0	59,0	43,0	33,0	

Model Three-phase 400V	P <sub>2</sub>		Q=Flow rate							
	[HP]	[kW]	l/min	300	400	500	550	600	700	750
			m <sup>3</sup> /h	18	24	30	33	36	42	45
			H=Head [m]							
SF6 S32-2	4	3	28,5	26,5	23,5	22,0	19,7	14,6	11,4	
SF6 S32-3	5,5	4	43,0	40,0	35,5	32,5	29,5	22,0	17,1	
SF6 S32-4	7,5	5,5	57,0	53,0	47,0	43,5	39,5	29,0	23,0	
SF6 S32-5	10	7,5	71,5	66,5	59,0	54,5	49,5	36,5	28,5	
SF6 S32-6	12,5	9,2	86,0	80,0	71,0	65,5	59,0	44,0	34,0	

Model Three-phase 400V	P <sub>2</sub>		Q=Flow rate								
	[HP]	[kW]	l/min	400	500	600	700	750	800	900	1000
			m <sup>3</sup> /h	24	30	36	42	45	48	54	60
			H=Head [m]								
SF6 S42-2	5,5	4	22,5	21,0	19,2	17,1	16,0	14,5	11,4	8,0	
SF6 S42-3	7,5	5,5	33,5	31,5	29,0	25,5	24,0	22,0	17,2	12,0	
SF6 S42-4	10	7,5	45,0	42,0	38,5	34,0	31,5	29,0	23,0	16,0	
SF6 S42-5	12,5	9,2	56,0	52,5	48,0	42,5	39,5	36,5	28,5	20,0	
SF6 S42-6	15	11	67,0	63,0	57,5	51,0	47,5	43,5	34,5	24,0	
SF6 S42-8	20	15	89,5	84,0	77,0	68,0	63,5	58,0	46,0	32,0	
SF6 S42-9	20	15	101,0	94,5	86,5	77,0	71,5	65,5	51,5	36,0	

Model Three-phase 400V	P <sub>2</sub>		Q=Flow rate								
	[HP]	[kW]	l/min	100	130	160	200	240	280	320	350
			m <sup>3</sup> /h	6	8	10	12	14	17	19	21
			H=Head [m]								
WINNER 4N15-13	4	3	64,0	60,0	56,0	49,0	43,0	35,0	27,0	21,0	
WINNER 4N15-17	5,5	4	83,0	78,0	73,0	64,0	56,0	46,0	36,0	27,0	
WINNER 4N15-24	7,5	5,5	118,0	110,0	103,0	91,0	78,0	65,0	50,0	38,0	

Model Three-phase 400V	P <sub>2</sub>		Q=Flow rate					
	[HP]	[kW]	l/min	100	150	200	250	300
			m <sup>3</sup> /h	6	9	12	15	18
			H=Head [m]					
SF6 R13-4	3	2,2	60,5	57,0	51,0	42,0	29,5	
SF6 R13-5	4	3	75,5	71,5	64,0	52,5	37,0	
SF6 R13-6	5,5	4	90,5	85,5	76,5	63,0	44,5	
SF6 R13-7	7,5	5,5	106,0	100,0	89,5	73,5	52,0	

**PERFORMANCE TABLE FOR IDROGO (JOCKEY) PUMP**

Model	P <sub>2</sub>		Q=Flow rate					
	[HP]	[kW]	l/min	20	30	40	60	80
			m <sup>3</sup> /h	1,2	1,8	2,4	3,6	4,8
			H=Head [m]					
IDROGO 40/08	0,8	0,6	43,3	40,2	36,3	26,1	13,4	
IDROGO 40/10	1	0,75	54,1	50,2	45,4	32,6	16,8	
IDROGO 40/12	1,2	0,9	64,9	60,2	54,5	39,2	20,2	
IDROGO 40/15	1,5	1,1	75,7	70,3	63,6	45,7	23,5	

**PERFORMANCE TABLE FOR WINNER 4N (JOCKEY) PUMP**

Model	P <sub>2</sub>		Q=Flow rate								
	[HP]	[kW]	l/min	10	15	20	30	35	45	55	95
			m <sup>3</sup> /h	0,6	0,9	1,2	1,8	2,1	2,7	3,3	5,7
			H=Head [m]								
WINNER 4N1- 18	0,7	0,55	95,0	89,0	80,0	54,0	38,0	-	-	-	
WINNER 4N1- 24	1	0,75	127,0	119,0	107,0	72,0	50,0	-	-	-	
WINNER 4N2- 20	1,5	1,1	-	131,0	127,0	113,0	103,0	75,0	38,0	-	
WINNER 4N4- 18	2	1,5	-	-	-	114,0	111,0	104,0	96,0	32,0	

The contents of this publication should not be regarded as binding. EBARA Pumps Europe S.p.A. reserves the right to alter any modification it deems necessary, without prior notice.

## FFS-S FIRE-FIGHTING UNIT KITS

PERFORMANCE TABLE FOR BHE(L) SUBMERGED PUMPS

Model Three-phase 400V	P:		Q=Flow rate							
	[HP]	[kW]	l/min	100	150	200	250	300	400	450
			m³/h	6	9	12	15	18	24	27
			H=Head [m]							
6BHE(L) 13-8	5,5	4	81,1	77,5	72,7	66,3	50,0	29,7	-	-

Model	P:		Q=Flow rate									
	[HP]	[kW]	l/min	100	133	167	200	250	300	350	400	450
			m³/h	6	8	10	12	15	18	21	24	27
			H=Head [m]									
6BHE(L) 20-6	5,5	4	68,0	66,4	64,0	62,0	57,6	51,6	43,2	32,9	20,5	
6BHE(L) 20-9	7,5	5,5	102,0	99,6	96,0	93,0	86,4	77,4	64,8	49,4	30,8	
6BHE(L) 20-10	10	7,5	113,7	110,7	106,7	103,3	96,0	86,0	72,0	54,9	34,2	

Model	P:		Q=Flow rate									
	[HP]	[kW]	l/min	83,5	166,5	250	333,5	416,5	500	583,5	666,5	750
			m³/h	5	10	15	20	25	30	35	40	45
			H=Head [m]									
6BHE(L) 32-3	5	4	43,9	41,4	38,9	36,0	33,3	30,2	26,7	21,7	15,3	
6BHE(L) 32-4	7,5	5,5	59,5	56,0	52,6	48,8	45,2	41,1	36,5	30,0	21,4	
6BHE(L) 32-5	10	7,5	74,2	70,2	66,2	61,5	56,9	51,8	46,1	38,0	27,4	
6BHE(L) 32-6	10	7,5	88,4	83,4	78,4	72,6	67,1	61,0	54,0	44,1	31,2	
6BHE(L) 32-7	12,5	9,3	104,2	98,4	92,6	86,0	79,7	72,6	64,6	53,3	38,4	

Model	P:		Q=Flow rate								
	[HP]	[kW]	l/min	416,5	500	583,5	666,5	750	833,5	916,5	1000
			m³/h	25	30	35	40	45	50	55	60
			H=Head [m]								
6BHE(L) 48-2	4	3	22,6	20,9	19,3	17,8	16,6	15,1	13,4	11,3	
6BHE(L) 48-3	5,5	4	33,8	31,2	28,8	26,6	24,7	22,5	19,9	16,8	
6BHE(L) 48-4	7,5	5,5	45,0	41,5	38,3	35,5	32,9	29,9	26,5	22,3	
6BHE(L) 48-5	10	7,5	56,8	52,3	48,3	44,7	41,5	37,8	33,6	28,4	
6BHE(L) 48-6	12,5	9,3	70,0	65,2	60,4	55,5	50,3	46,0	41,6	35,7	
6BHE(L) 48-7	12,5	9,3	80,4	74,8	69,3	63,5	57,6	52,7	47,5	40,5	
6BHE(L) 48-8	15	11	91,6	85,1	78,9	72,2	65,5	59,9	54,0	46,0	
6BHE(L) 48-9	20	15	105,5	98,2	91,0	83,7	75,9	69,5	62,9	54,1	

Model	P:		Q=Flow rate								
	[HP]	[kW]	l/min	666,5	750	833,5	916,5	1000	1083,5	1166,5	1250
			m³/h	40	45	50	55	60	65	70	75
			H=Head [m]								
6BHE(L) 64-2	5	4	21,1	19,0	17,3	16,5	15,7	14,9	13,9	12,4	
6BHE(L) 64-3	7,5	5,5	31,8	28,8	26,2	24,9	23,7	22,5	21,0	18,9	
6BHE(L) 64-4	10	7,5	42,5	38,4	35,0	33,2	31,6	30,1	28,0	25,2	
6BHE(L) 64-5	12,5	9,3	53,8	48,7	44,3	41,9	40,1	38,2	35,6	32,2	
6BHE(L) 64-6	15	11	64,0	57,9	52,7	50,0	47,7	45,3	42,3	38,1	
6BHE(L) 64-7	20	15	76,2	70,1	65,2	61,7	58,6	55,7	52,1	46,1	
6BHE(L) 64-8	20	15	86,0	79,1	73,5	69,7	66,1	62,8	58,5	51,6	
6BHE(L) 64-9	20	15	95,5	87,8	81,5	77,4	73,4	69,6	64,6	56,8	

Model Three-phase 400V	P:		Q=Flow rate							
	[HP]	[kW]	l/min	600	700	1000	1250	1500	1700	2100
			m³/h	36	42	60	75	90	102	126
			H=Head [m]							
86 BHEL 77-2	10	7,5	37,0	35,7	30,6	26,3	21,1	16,4	13,6	
86 BHEL 77-3	15	11	55,5	53,5	46,0	39,5	31,6	24,6	20,4	
86 BHEL 77-4	20	15	74,0	71,5	61,0	52,5	42,0	32,8	27,2	
86 BHEL 77-5	25	18,5	92,5	89,5	76,5	66,0	52,5	41,0	34,0	
86 BHEL 77-6	30	22	111,0	107,0	92,0	79,0	63,0	49,0	41,0	

Model Three-phase 400V	P:		Q=Flow rate							
	[HP]	[kW]	l/min	700	1000	1250	1500	1700	1900	2100
			m³/h	42	60	75	90	102	114	126
			H=Head [m]							
86 BHEL 95-2	12,5	9,2	38,8	34,0	30,2	26,4	22,8	18,4	13,6	
86 BHEL 95-3	20	15	58,0	51,0	45,5	39,6	34,2	27,6	20,4	
86 BHEL 95-4	25	18,5	77,5	68,0	60,5	53,0	45,5	36,8	27,2	
86 BHEL 95-5	30	22	97,0	85,0	75,5	66,0	57,0	46,0	34,0	
86 BHEL 95-6	40	30	116,0	102,0	90,5	79,0	68,5	55,0	41,0	

PERFORMANCE TABLE FOR IDROGO (JOCKEY) PUMP

Model	P:		Q=Flow rate					
	[HP]	[kW]	l/min	20	30	40	60	80
			m³/h	1,2	1,8	2,4	3,6	4,8
			H=Head [m]					
IDROGO 40/08	0,8	0,6	43,3	40,2	36,3	26,1	13,4	
IDROGO 40/10	1	0,75	54,1	50,2	45,4	32,6	16,8	
IDROGO 40/12	1,2	0,9	64,9	60,2	54,5	39,2	20,2	
IDROGO 40/15	1,5	1,1	75,7	70,3	63,6	45,7	23,5	

PERFORMANCE TABLE FOR WINNER 4N (JOCKEY) PUMP

Model	P:		Q=Flow rate								
	[HP]	[kW]	l/min	10	15	20	30	35	45	55	95
			m³/h	0,6	0,9	1,2	1,8	2,1	2,7	3,3	5,7
			H=Head [m]								
WINNER 4N1- 18	0,7	0,55	95,0	89,0	80,0	54,0	38,0	-	-	-	
WINNER 4N1- 24	1	0,75	127,0	119,0	107,0	72,0	50,0	-	-	-	
WINNER 4N2- 20	1,5	1,1	-	131,0	127,0	113,0	103,0	75,0	38,0	-	
WINNER 4N4- 18	2	1,5	-	-	-	114,0	111,0	104,0	96,0	32,0	



# FFS-FFB

## FFS-S FIRE-FIGHTING UNIT KITS

PERFORMANCE CURVES for series SF6 S25 (impeller diameter - 111.5 mm) in accordance with ISO 9906 Annex A

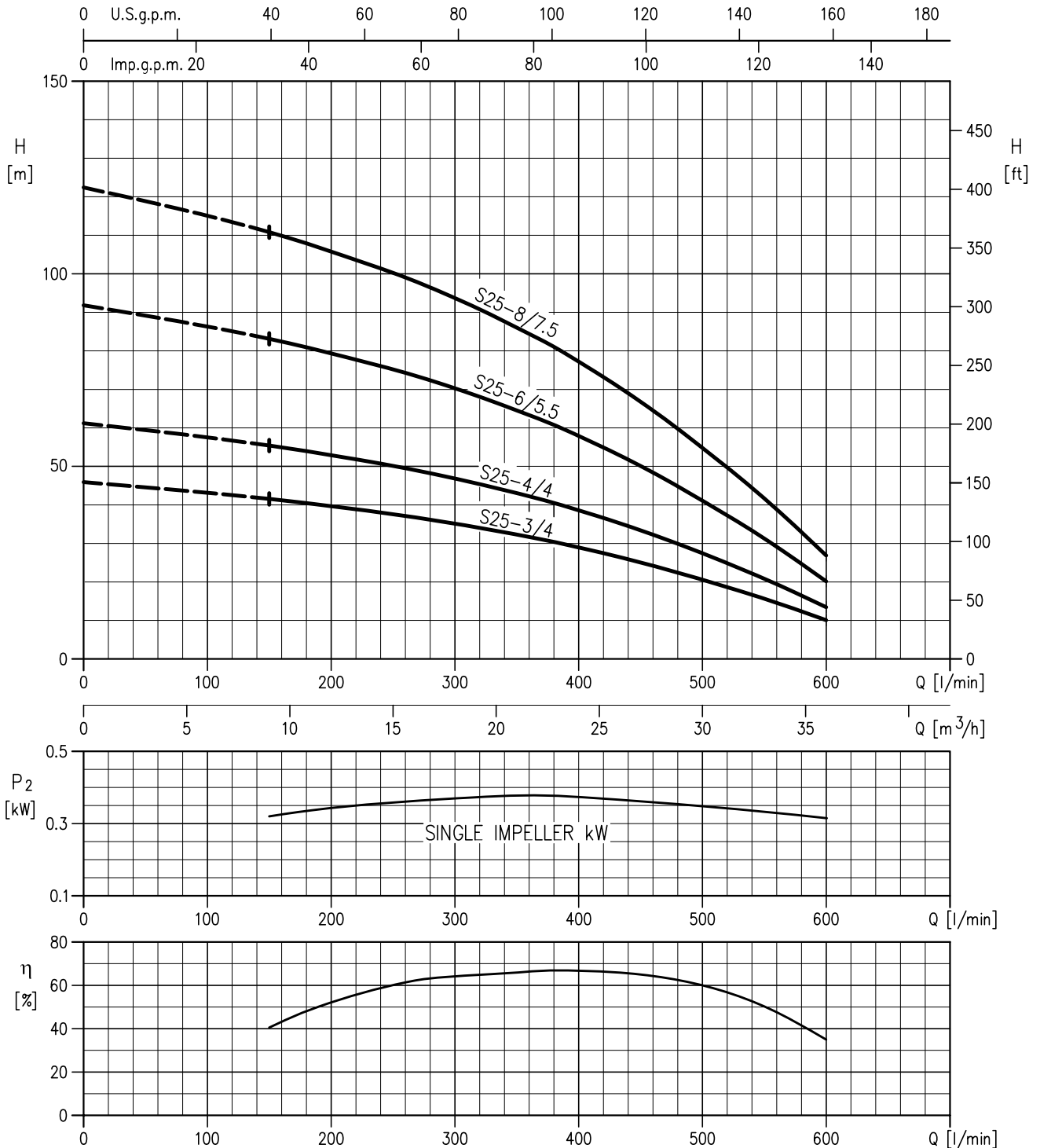

The contents of the publication should not be regarded as binding. EBARA Pumps Europe S.p.A. reserves the right to effect any modification it deems necessary, without prior notice.



# FFS-FFB

## FFS-S FIRE-FIGHTING UNIT KITS

PERFORMANCE CURVES for series SF6 S32 (impeller diameter - 113.7 mm) in accordance with ISO 9906 Annex A

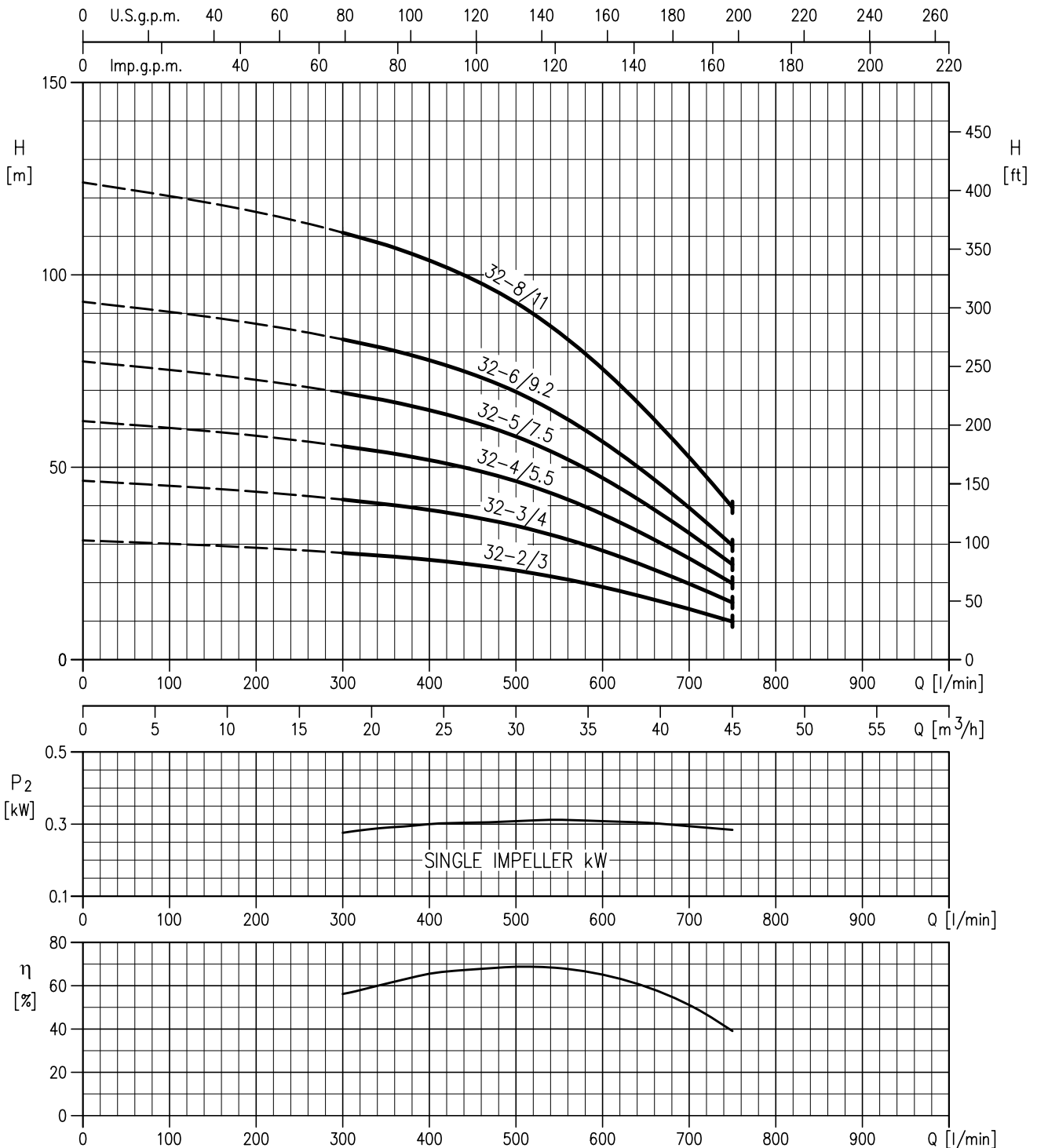

The contents of this publication should not be regarded as binding. EBARA Pumps Europe S.p.A. reserves the right to effect any modification it deems necessary, without prior notice.

## FFS-S FIRE-FIGHTING UNIT KITS

PERFORMANCE CURVES for series SF6 S42 (impeller diameter - 114 mm) in accordance with ISO 9906 Annex A

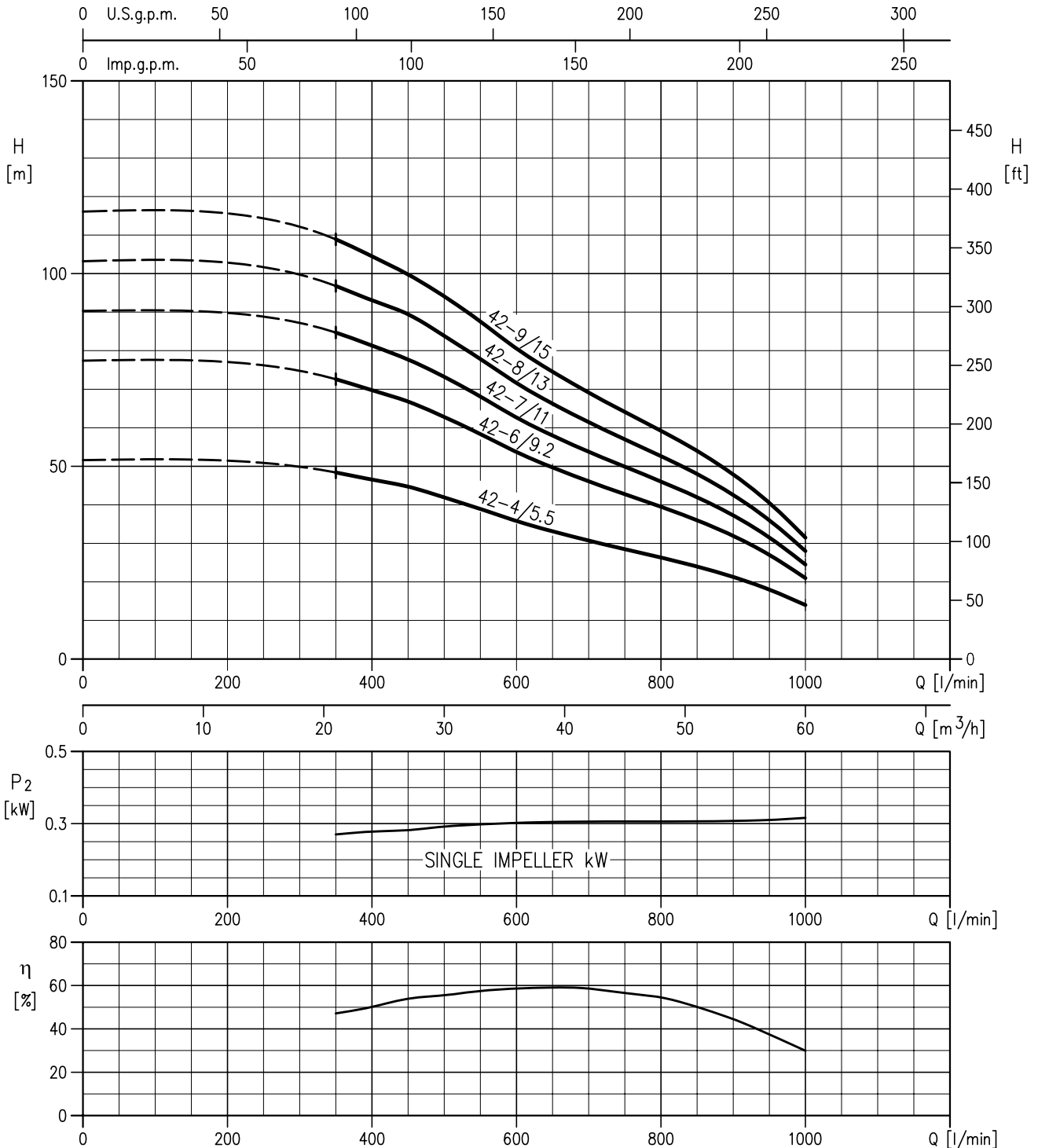

The contents of the publication should not be regarded as binding. EBARA Pumps Europe S.p.A. reserves the right to effect any modification it deems necessary, without prior notice.



# FFS-FFB

## FFS-S FIRE-FIGHTING UNIT KITS

PERFORMANCE CURVES for series WINNER 4N15 (impeller diameter - 75.5 mm) in accordance with ISO 9906 Annex A

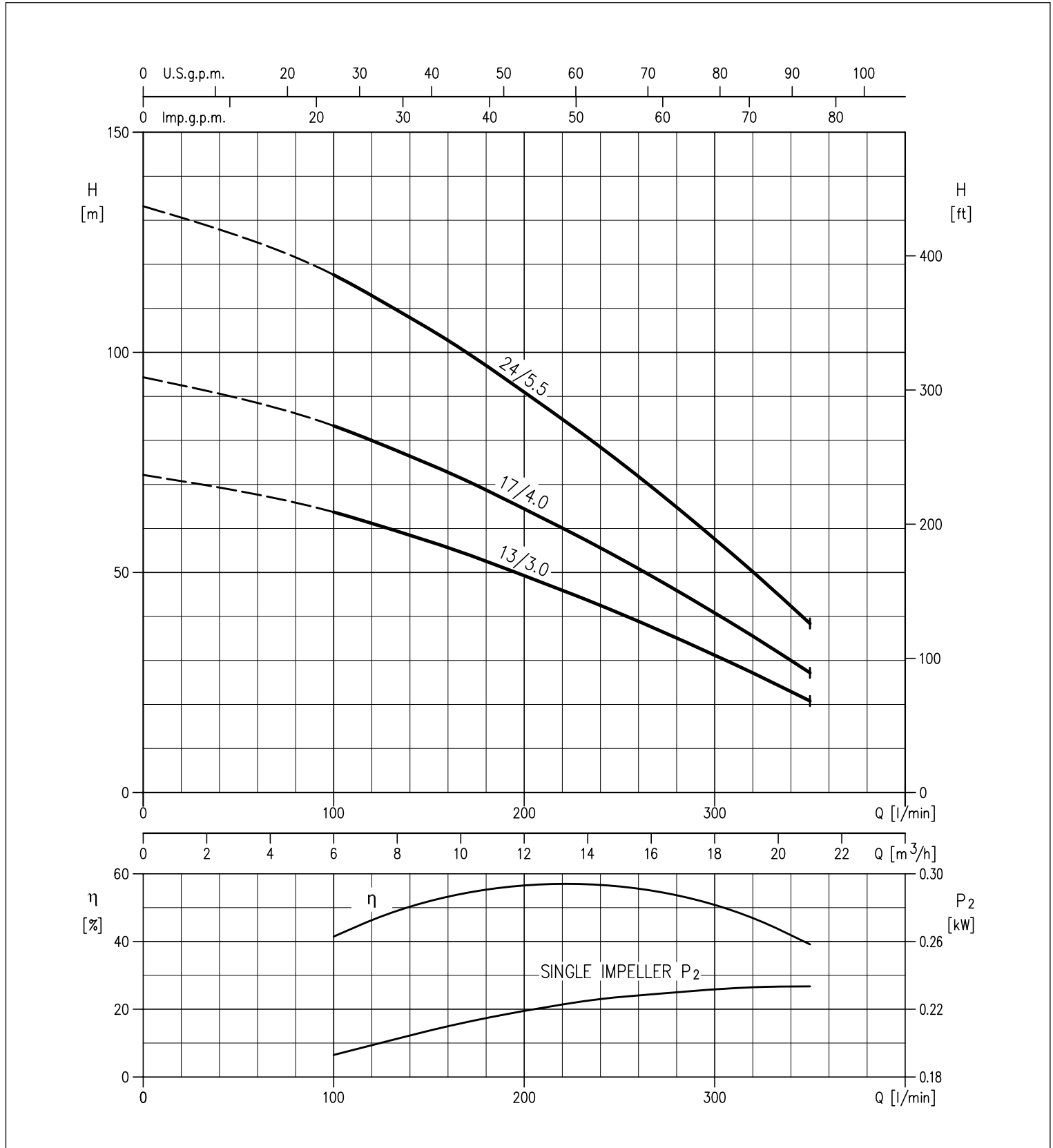

The contents of this publication should not be regarded as binding. EBARA Pompa Europe S.p.A. reserves the right to effect any modification it deems necessary, without prior notice.



# FFS-FFB

## FFS-S FIRE-FIGHTING UNIT KITS

PERFORMANCE CURVES for series SF6 R13 (impeller diameter - 117 mm) in accordance with ISO 9906 Annex A

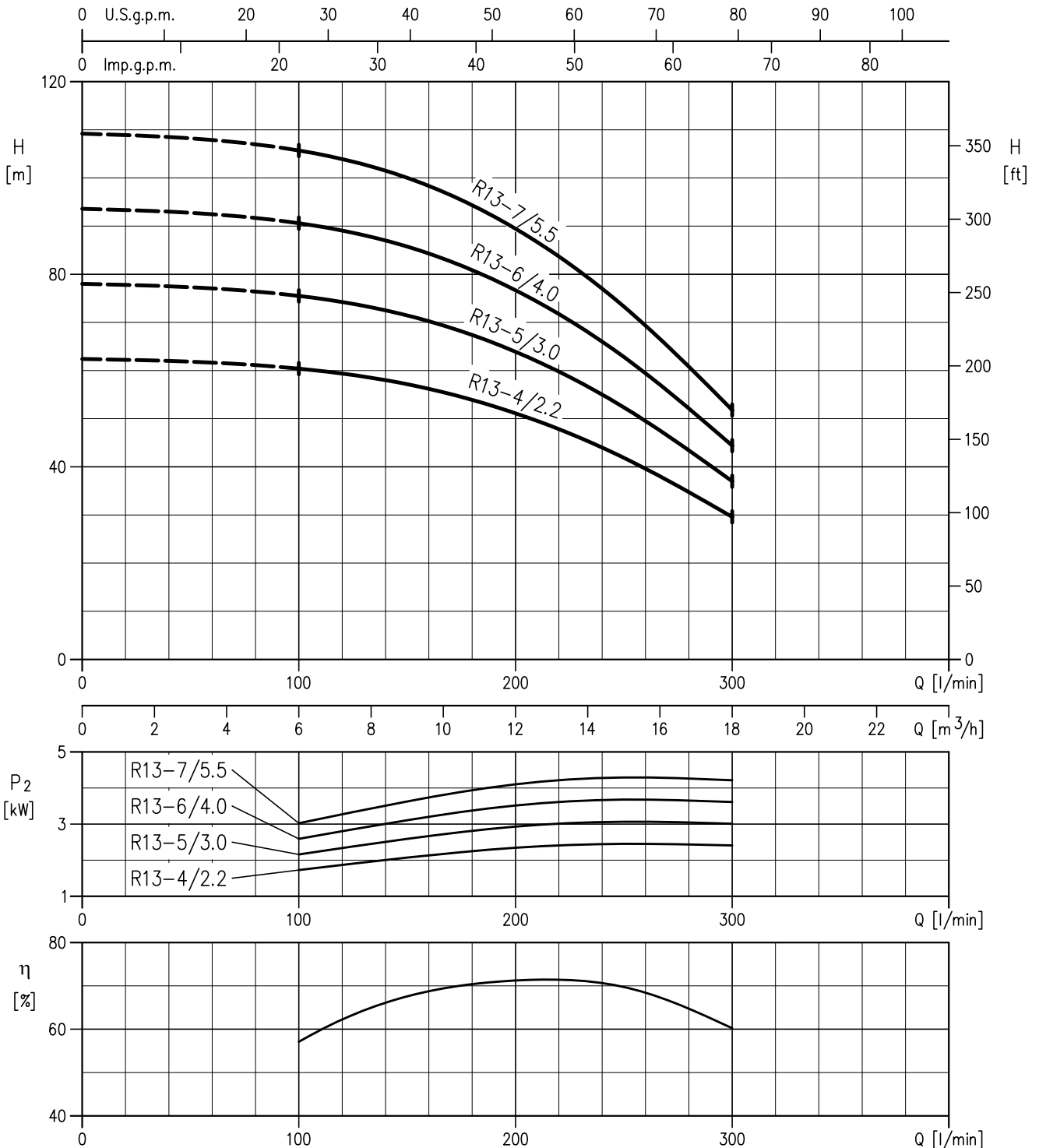

The contents of this publication should not be regarded as binding. EBARA Pumps Europe S.p.A. reserves the right to effect any modification it deems necessary, without prior notice.

## FFS-S FIRE-FIGHTING UNIT KITS

PERFORMANCE CURVES for series 6BHE13-20 (impeller diameter - 104 mm) in accordance with ISO 9906 Annex A

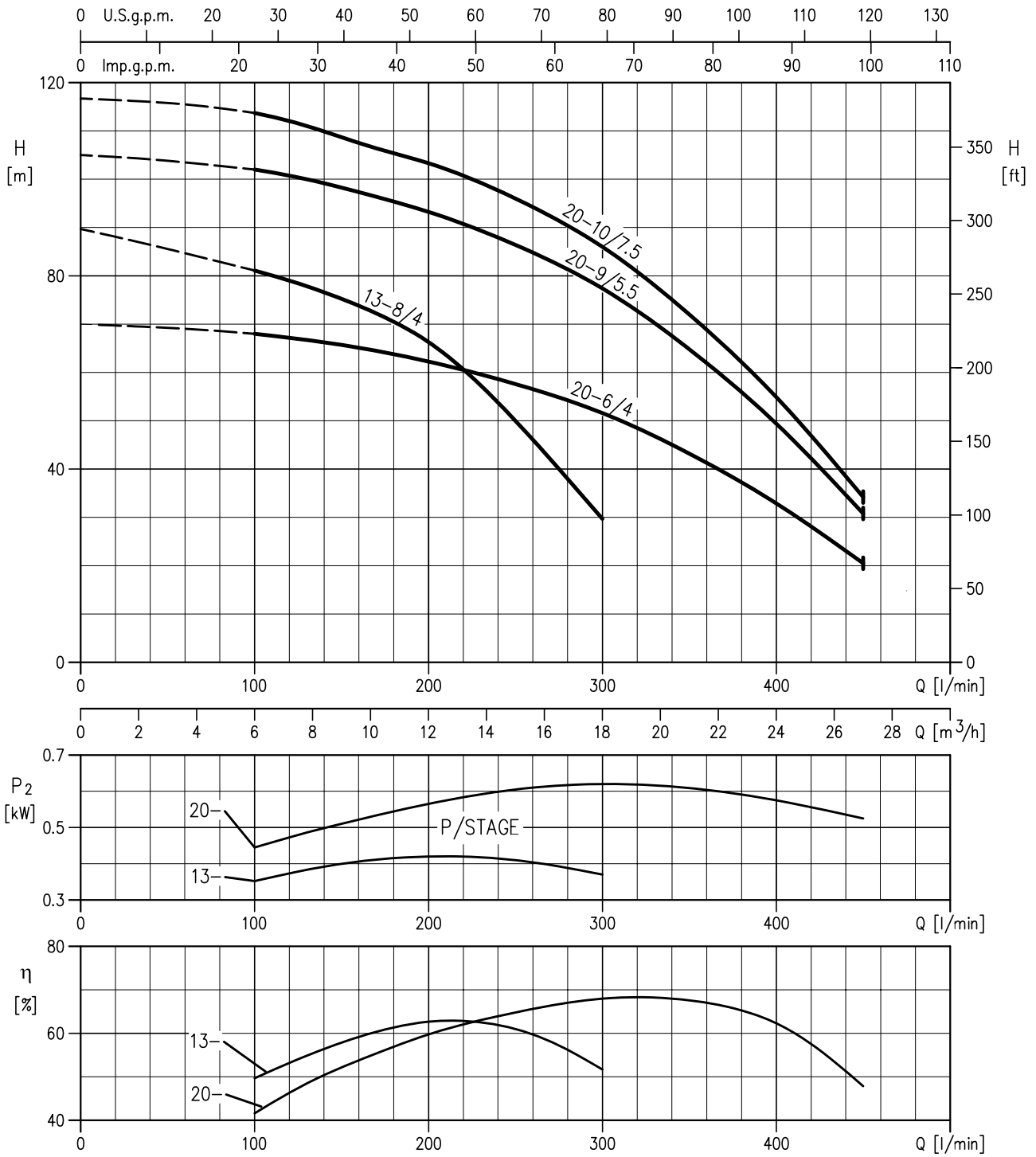

## FFS-S FIRE-FIGHTING UNIT KITS

PERFORMANCE CURVES for series 6BHE 32 (impeller diameter - 104 mm) in accordance with ISO 9906 Annex A

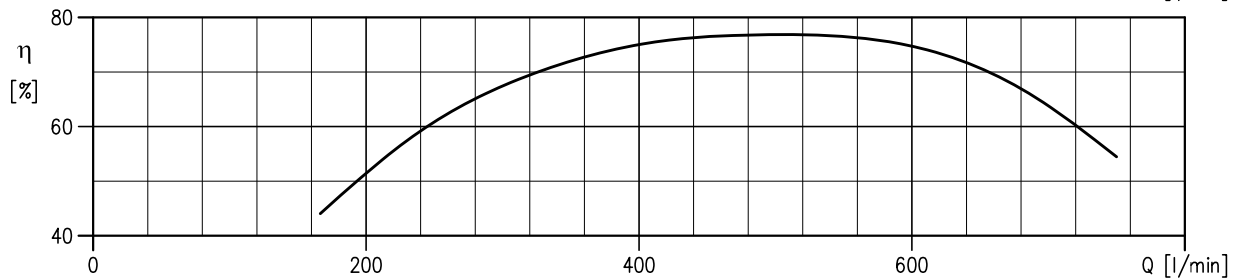
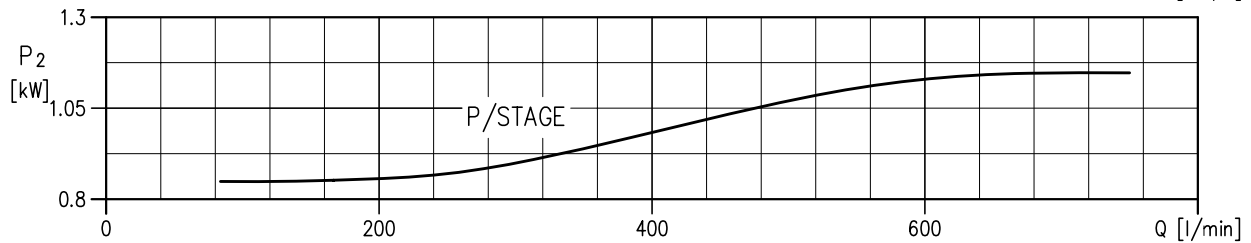
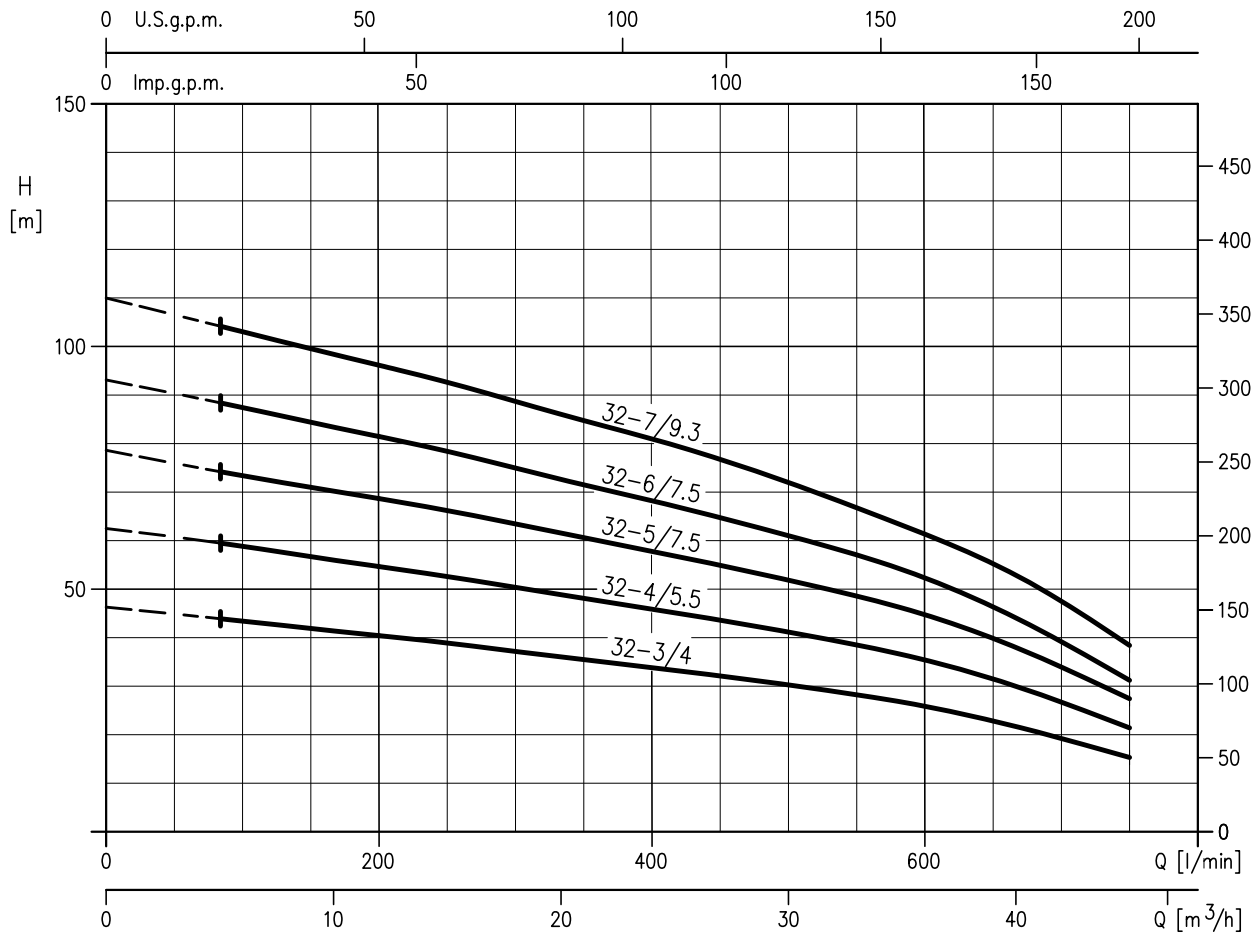

The contents of the publication should not be regarded as binding. EBARA Pumps Europe S.p.A. reserves the right to effect any modification it deems necessary, without prior notice.

## FFS-S FIRE-FIGHTING UNIT KITS

PERFORMANCE CURVES for series 6BHE 48 (impeller diameter - 110.5 mm) in accordance with ISO 9906 Annex A

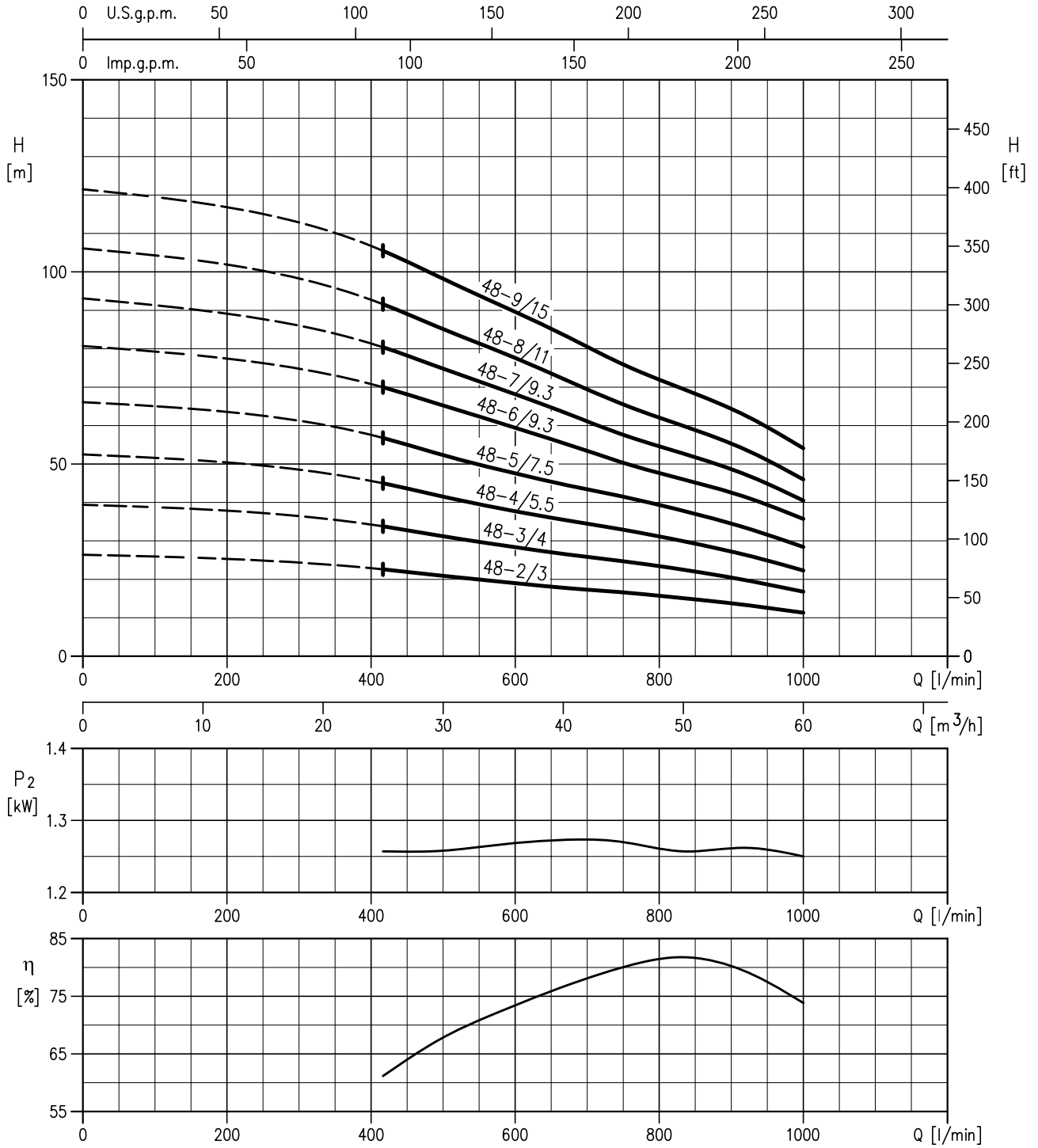

The contents of the publication should not be regarded as binding. EBARA Pumps Europe S.p.A. reserves the right to effect any modification it deems necessary, without prior notice.



# FFS-FFB

## FFS-S FIRE-FIGHTING UNIT KITS

PERFORMANCE CURVES for series 6BHE 64 (impeller diameter - 103 mm) in accordance with ISO 9906 Annex A

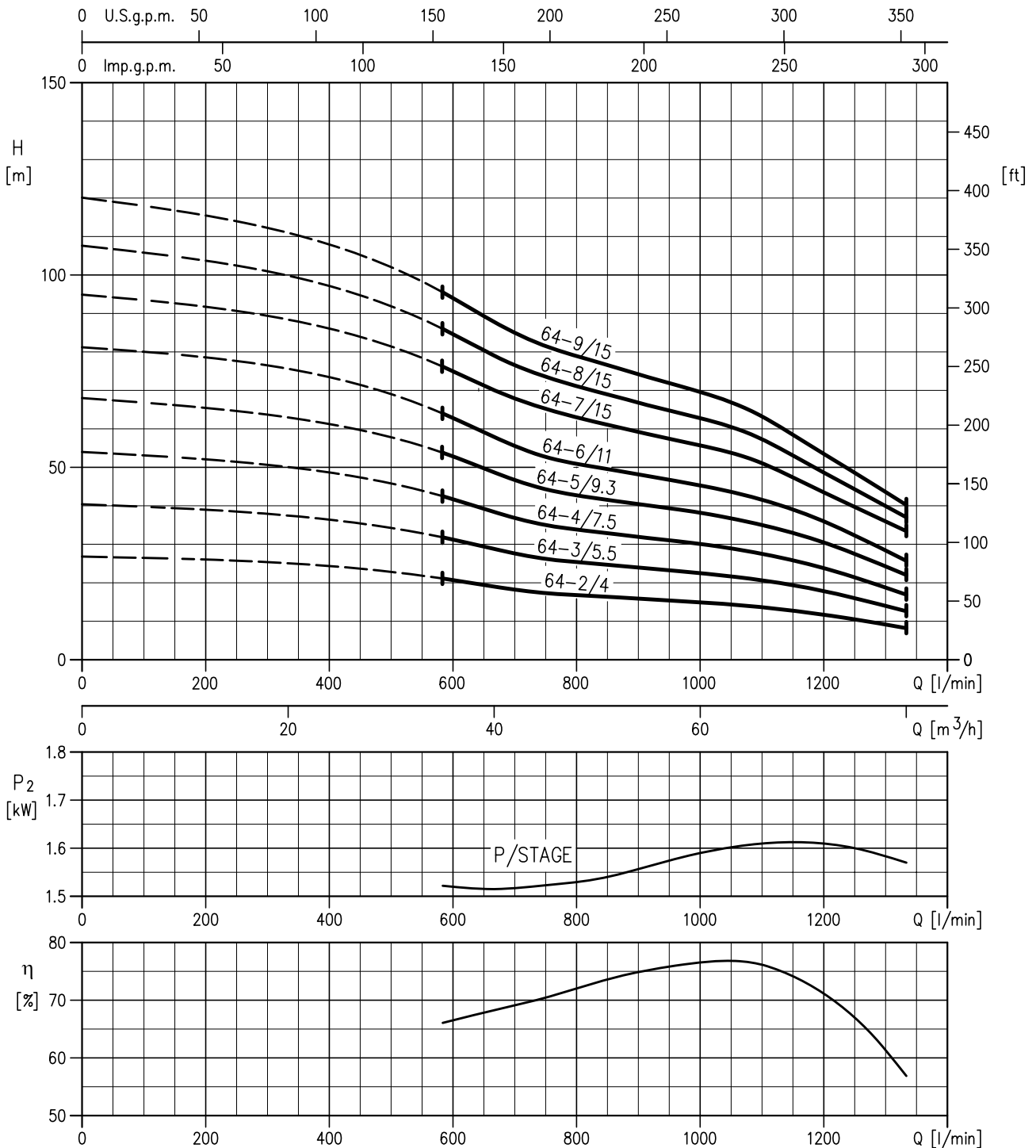

The contents of the publication should not be regarded as binding. EBARA Pumps Europe S.p.A. reserves the right to effect any modification it deems necessary, without prior notice.



# FFS-FFB

## FFS-S FIRE-FIGHTING UNIT KITS

PERFORMANCE CURVES for series 8BHEL 77 (impeller diameter - 114 mm) in accordance with ISO 9906 Annex A

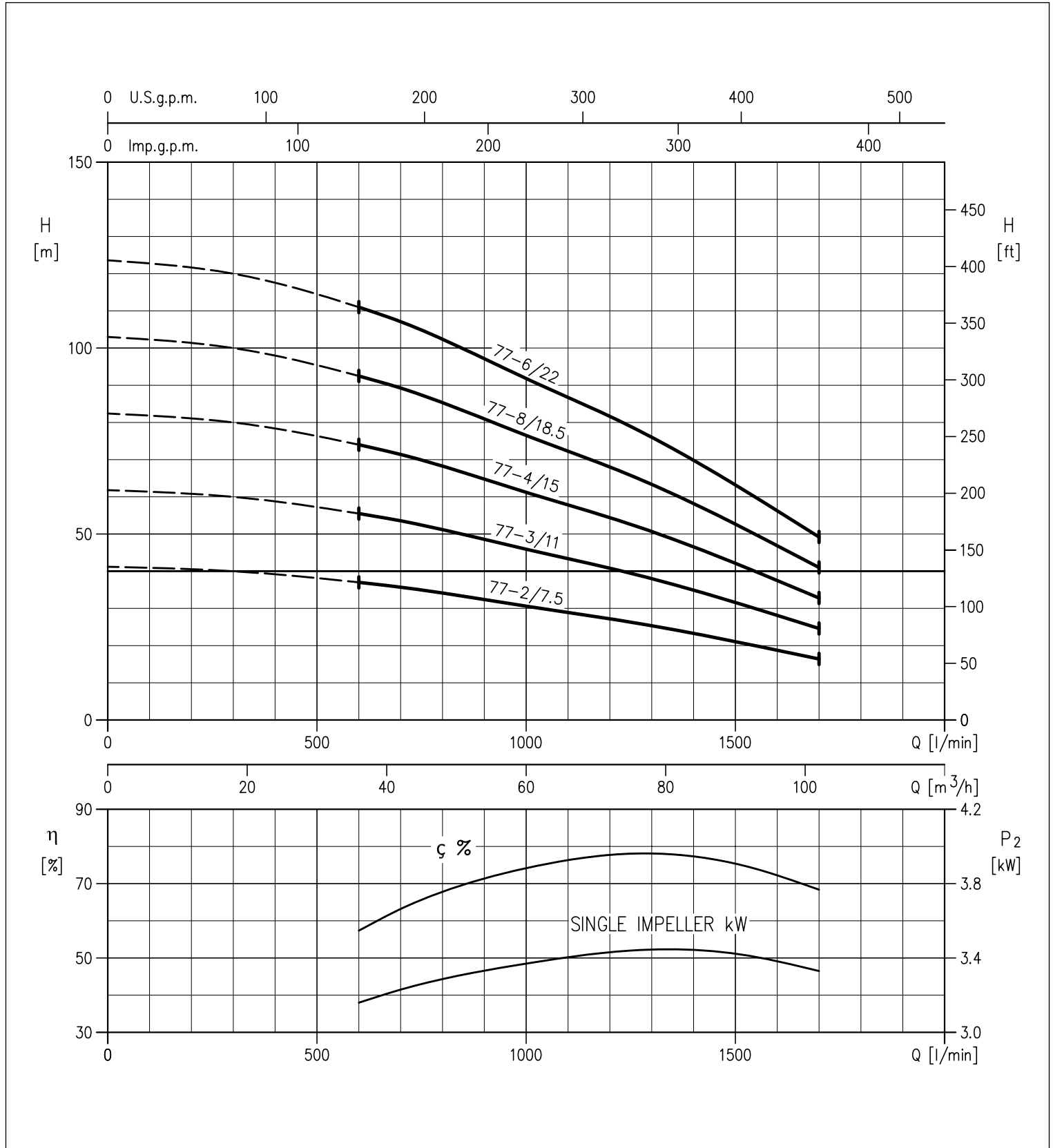

The contents of the publication should not be regarded as binding. EBARA Pumps Europe S.p.A. reserves the right to effect any modification deemed necessary, without prior notice.



# FFS-FFB

## FFS-S FIRE-FIGHTING UNIT KITS

PERFORMANCE CURVES for series 8BHEL 95 (impeller diameter - 117 mm) in accordance with ISO 9906 Annex A

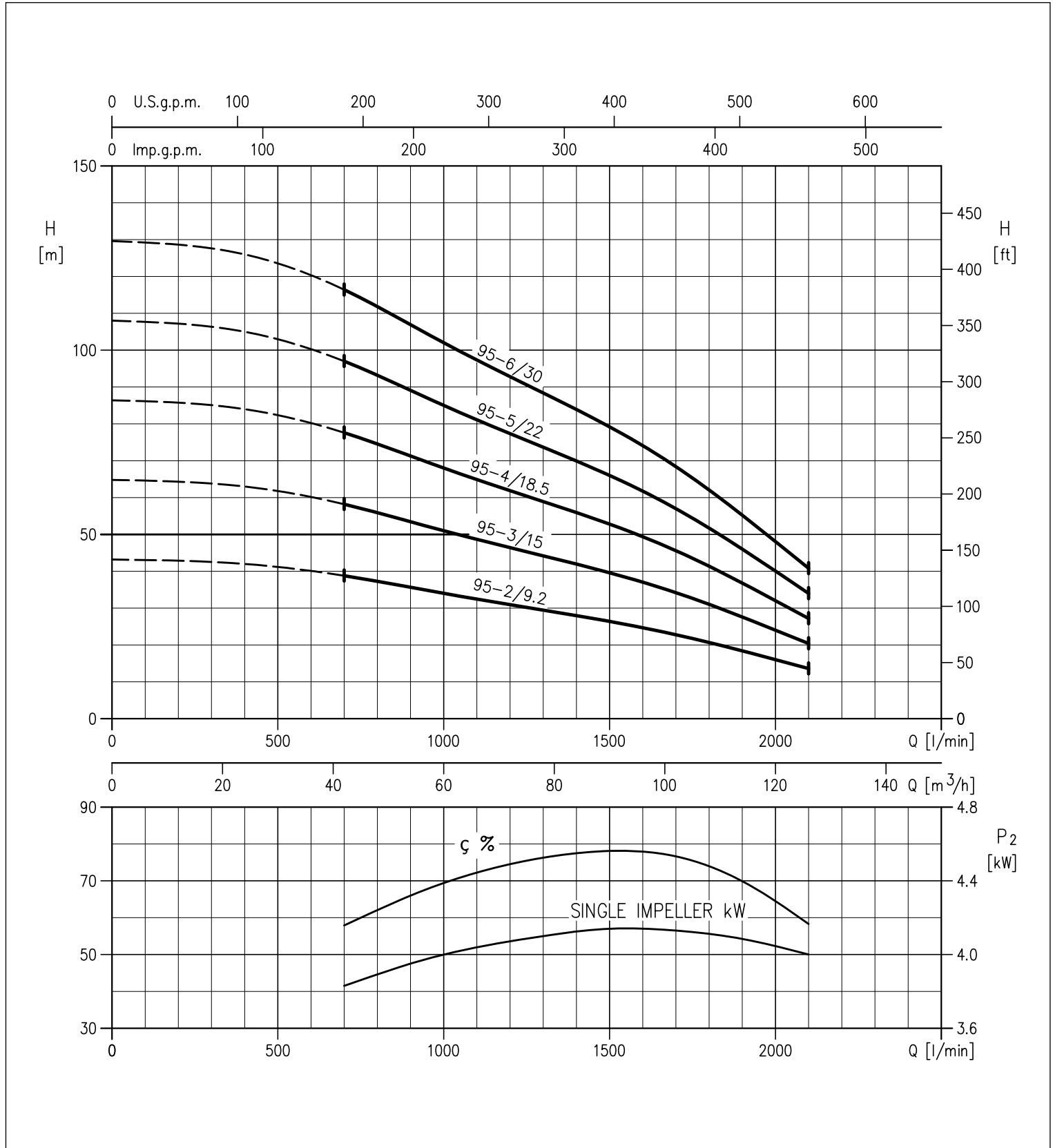

The contents of the publication should not be regarded as binding. EBARA Pumps Europe S.p.A. reserves the right to effect any modification it deems necessary, without prior notice.

## FFS-S FIRE-FIGHTING UNIT KITS

### FFS115 DIMENSIONS - MULTI-STAGE SUBMERGED ELECTRICAL PUMPS (SF6 - WINNER 4N15) + PILOT

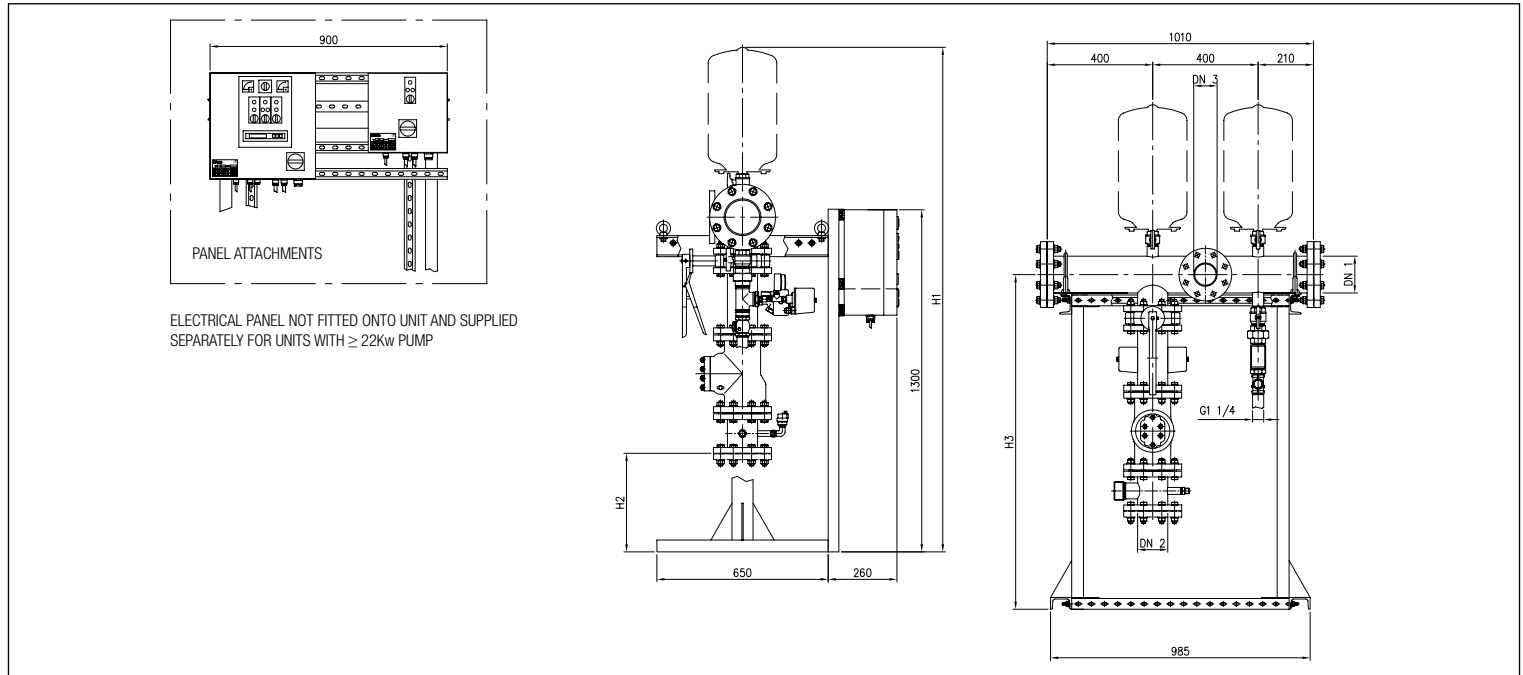

### DIMENSIONS CHART

Model	Pilot pump	Dimensions [mm]					
		DN1	DN2	DN3	H1	H2	H3
WINNER 4N15 13.3	IDROGO 40/12	65	50	1"½	1950	525	1340
WINNER 4N15 17.4	WINNER 4N2-14	65	50	1"½	1950	525	1340
WINNER 4N15 24/5.5	WINNER 4N2-20	65	50	1"½	1950	525	1340
SF6 25-3.3	IDROGO 40 10	80	65	2"	1965	440	1345
SF6 25-4.4	IDROGO 40 12	80	65	2"	1965	440	1345
SF6 25-6/5.5	WINNER 4N2-14	80	65	2"	1965	440	1345
SF6 25-8 17.5	WINNER 4N4-18	80	65	2"	1965	440	1345
SF6 32-2.3	IDROGO 40 08	80	80	2"	1965	420	1345
SF6 32-3.4	IDROGO 40 10	80	80	2"	1965	420	1345
SF6 32-4/5.5	IDROGO 40/12	80	80	2"	1965	420	1345
SF6 32-5/7.5	IDROGO 40/15	80	80	2"	1965	420	1345
SF6 32-6/9.2	WINNER 4N2-14	80	80	2"	1965	420	1345
SF6 32-8/11	WINNER 4N4-18	80	80	2"	1965	420	1345
SF6 42-4/7.5	IDROGO 40/10	100	80	2"½	1990	420	1355
SF6 42-6/9.2	IDROGO 40/15	100	80	2"½	1990	420	1355
SF6 42-7 11	WINNER 4N2-14	100	80	2"½	1990	420	1355
SF6 42-8 13	WINNER 4N4-18	100	80	2"½	1990	420	1355
SF6 42-9 15	WINNER 4N4-18	100	80	2"½	1990	420	1355

## FFS-S FIRE-FIGHTING UNIT KITS

### FFS11S DIMENSIONS - MULTI-STAGE SUBMERGED ELECTRICAL PUMPS (BHE) + PILOT

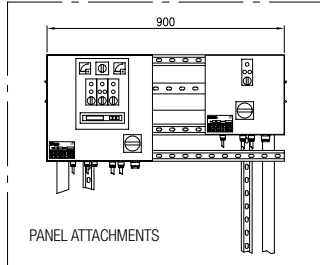

ELECTRICAL PANEL NOT FITTED ONTO UNIT AND SUPPLIED SEPARATELY FOR UNITS WITH  $\geq 22\text{kW}$  PUMP

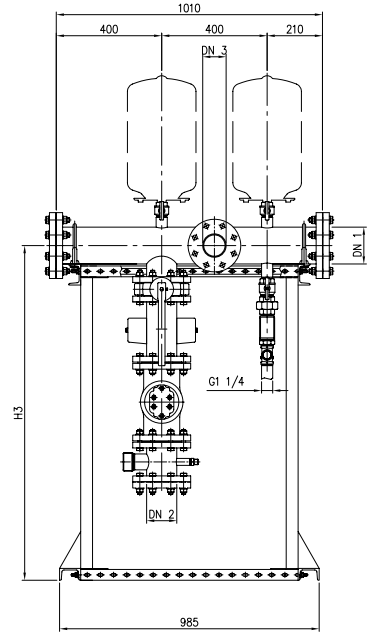
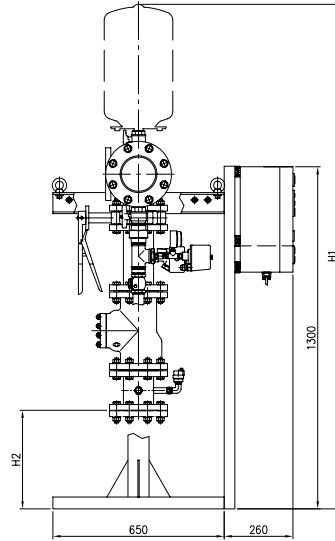

### DIMENSIONS CHART

Model	Pilot pump	Dimensions [mm]					
		DN1	DN2	DN3	H1	H2	H3
6 BHE 13-8	WINNER 4N2-14	65	50	1"½	1950	525	1340
6 BHE 20-6	IDROGO 40/12	65	65	2"	1950	440	1340
6 BHE 20-9	WINNER 4N4-18	65	65	2"	1950	440	1340
6 BHE 20-10	WINNER 4N4-18	65	65	2"	1950	440	1340
6 BHE 32-3	IDROGO 40/08	100	80	2"	1990	420	1355
6 BHE 32-4	IDROGO 40/12	100	80	2"	1990	420	1355
6 BHE 32-5	IDROGO 40/15	100	80	2"	1990	420	1355
6 BHE 32-6	IDROGO 40/15	100	80	2"	1990	420	1355
6 BHE 32-7	WINNER 4N4-18	100	80	2"	1990	420	1355
6 BHE 48-2	IDROGO 40/08	100	80	2"½	1990	420	1355
6 BHE 48-3	IDROGO 40/08	100	80	2"½	1990	420	1355
6 BHE 48-4	IDROGO 40/12	100	80	2"½	1990	420	1355
6 BHE 48-5	IDROGO 40/12	100	80	2"½	1990	420	1355
6 BHE 48-6	WINNER 4N4-18	100	80	2"½	1990	420	1355
6 BHE 48-7	WINNER 4N2-14	100	80	2"½	1990	420	1355
6 BHE 48-8	WINNER 4N4-18	100	80	2"½	1990	420	1355
6 BHE 48-9	WINNER 4N4-18	100	80	2"½	1990	420	1355
6 BHE 64-2	IDROGO 40/08	100	80	2"½	1990	420	1355
6 BHE 64-3	IDROGO 40/08	100	80	2"½	1990	420	1355
6 BHE 64-4	IDROGO 40/12	100	80	2"½	1990	420	1355
6 BHE 64-5	IDROGO 40/12	100	80	2"½	1990	420	1355
6 BHE 64-6	WINNER 4N2-14	100	80	2"½	1990	420	1355
6 BHE 64-7	WINNER 4N2-14	100	80	2"½	1990	420	1355
6 BHE 64-8	WINNER 4N4-18	100	80	2"½	1990	420	1355
6 BHE 64-9	WINNER 4N4-18	100	80	2"½	1990	420	1355
86 BHE 77-2	IDROGO 40/08	125	100	80	2015	375	1370
86 BHE 77-3	IDROGO 40 12	125	100	80	2015	375	1370
86 BHE 77-4	IDROGO 40 15	125	100	80	2015	375	1370
86 BHE 77-5	WINNER 4N4-18	125	100	80	2015	375	1370
86 BHE 77-6	WINNER 4N4-18	125	100	80	2015	375	1370
86 BHE 95-2	IDROGO 40/08	125	100	80	2015	375	1370
86 BHE 95-3	IDROGO 40/12	125	100	80	2015	375	1370
86 BHE 95-4	WINNER 4N2-14	125	100	80	2015	375	1370
86 BHE 95-5	WINNER 4N4-18	125	100	80	2015	375	1370
86 BHE 95-6	WINNER 4N2-20	125	100	80	2015	375	1370

The contents of this publication should not be regarded as binding. EBARA Pumps Europe S.p.A. reserves the right to effect any modification it deems necessary, without prior notice.

## FFS-S FIRE-FIGHTING UNIT KITS

### FFS21S DIMENSIONS - MULTI-STAGE SUBMERGED ELECTRICAL PUMPS (SF6 - WINNER 4N15) + PILOT

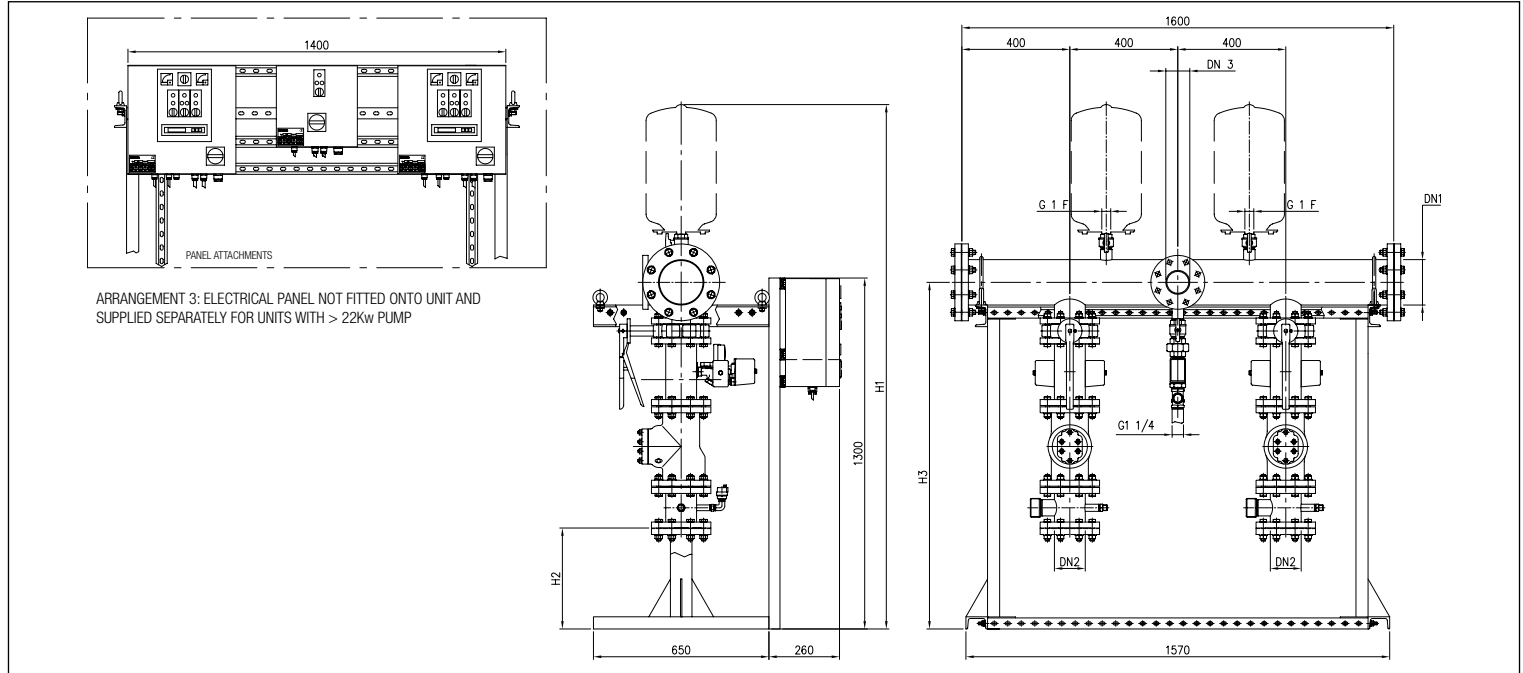

### DIMENSIONS CHART

Model	Pilot pump	Dimensions [mm]					
		DN1	DN2	L1	H1	H2	H3
WINNER 4N15 13/3	IDROGO 40/12	65	50	1"½	1950	525	1340
WINNER 4N15 17/4	WINNER 4N2-14	65	50	1"½	1950	525	1340
WINNER 4N15 24/5.5	WINNER 4N2-20	65	50	1"½	1950	525	1340
SF6 25-3/3	IDROGO 40/10	80	65	2"	1965	440	1345
SF6 25-4/4	IDROGO 40/12	80	65	2"	1965	440	1345
SF6 25-6/5.5	WINNER 4N2-14	80	65	2"	1965	440	1345
SF6 25-8/7.5	WINNER 4N4-18	80	65	2"	1965	440	1345
SF6 32-2/3	IDROGO 40/08	80	80	2.	1965	420	1345
SF6 32-3/4	IDROGO 40/10	80	80	2.	1965	420	1345
SF6 32-4/5.5	IDROGO 40/12	80	80	2.	1965	420	1345
SF6 32-5/7.5	IDROGO 40/15	80	80	2.	1965	420	1345
SF6 32-6/9.2	WINNER 4N2-14	80	80	2.	1965	420	1345
SF6 32-8/11	WINNER 4N4-18	80	80	2.	1965	420	1345
SF6 42-4/7.5	IDROGO 40/10	100	80	2.1/2	1990	420	1355
SF6 42-6/9.2	IDROGO 40/15	100	80	2.1/2	1990	420	1355
SF6 42-7/11	WINNER 4N2-14	100	80	2.1/2	1990	420	1355
SF6 42-8/13	WINNER 4N4-18	100	80	2.1/2	1990	420	1355
SF6 42-9/15	WINNER 4N4-18	100	80	2.1/2	1990	420	1355

The contents of this publication should not be regarded as binding. EBARA Pumps Europe S.p.A. reserves the right to effect any modification without prior notice.

## FFS-S FIRE-FIGHTING UNIT KITS

### FFS21S DIMENSIONS - MULTI-STAGE SUBMERGED ELECTRICAL PUMPS (BHE) + PILOT

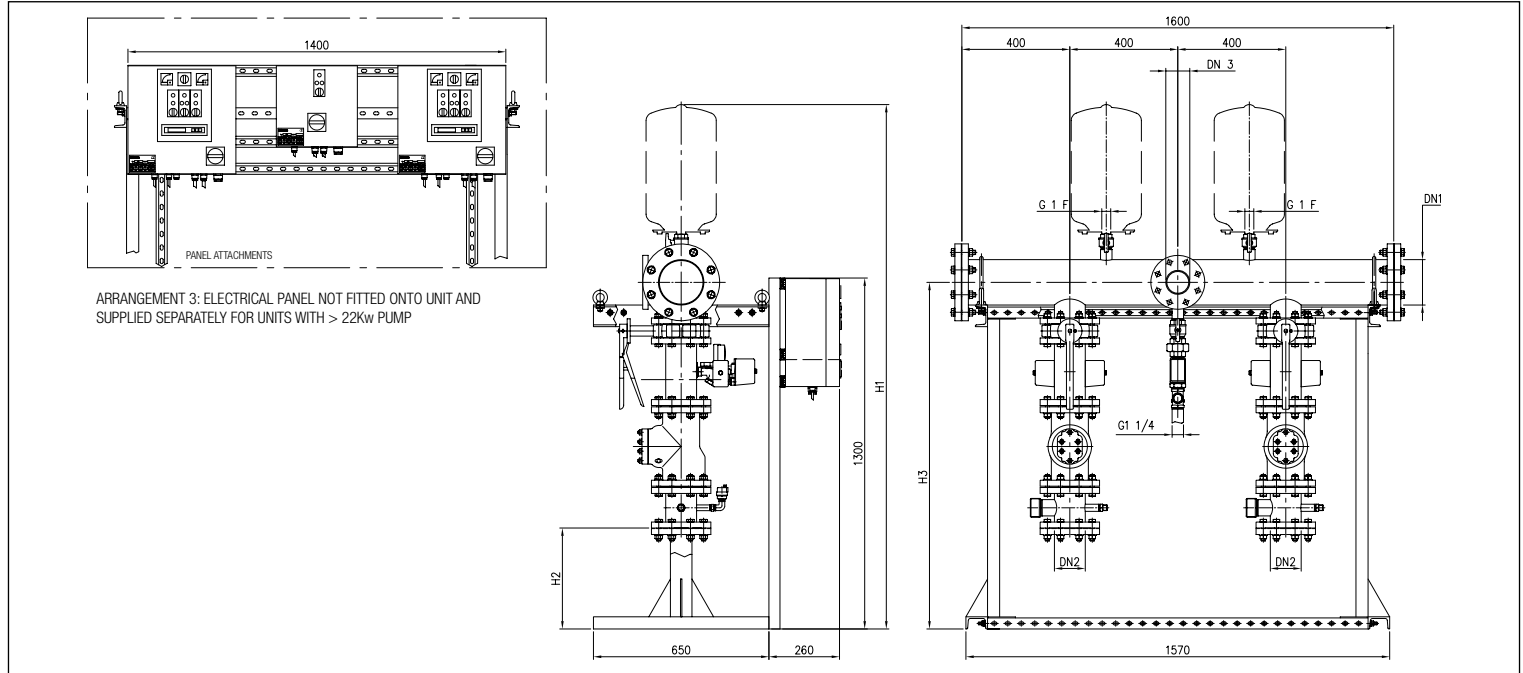

### DIMENSIONS CHART

Model	Pilot pump	Dimensions [mm]					
		DN1	DN2	L1	H1	H2	H3
6 BHE 13-8	WINNER 4N2-14	65	50	1"½	1950	525	1340
6 BHE 20-6	IDROGO 40/12	65	65	2"	1950	440	1340
6 BHE 20-9	WINNER 4N4-18	65	65	2"	1950	440	1340
6 BHE 20-10	WINNER 4N4-18	65	65	2"	1950	440	1340
6 BHE 32-3	IDROGO 40/08	100	80	2"	1990	420	1355
6 BHE 32-4	IDROGO 40/12	100	80	2"	1990	420	1355
6 BHE 32-5	IDROGO 40/15	100	80	2"	1990	420	1355
6 BHE 32-6	IDROGO 40/15	100	80	2"	1990	420	1355
6 BHE 32-7	WINNER 4N4-18	100	80	2"	1990	420	1355
6 BHE 48-2	IDROGO 40/08	100	80	2"½	1990	420	1355
6 BHE 48-3	IDROGO 40/08	100	80	2"½	1990	420	1355
6 BHE 48-4	IDROGO 40/12	100	80	2"½	1990	420	1355
6 BHE 48-5	IDROGO 40/12	100	80	2"½	1990	420	1355
6 BHE 48-6	WINNER 4N4-18	100	80	2"½	1990	420	1355
6 BHE 48-7	WINNER 4N2-14	100	80	2"½	1990	420	1355
6 BHE 48-8	WINNER 4N4-18	100	80	2"½	1990	420	1355
6 BHE 48-9	WINNER 4N4-18	100	80	2"½	1990	420	1355
6 BHE 64-2	IDROGO 40/08	100	80	2"½	1990	420	1355
6 BHE 64-3	IDROGO 40/08	100	80	2"½	1990	420	1355
6 BHE 64-4	IDROGO 40/12	100	80	2"½	1990	420	1355
6 BHE 64-5	IDROGO 40/12	100	80	2"½	1990	420	1355
6 BHE 64-6	WINNER 4N2-14	100	80	2"½	1990	420	1355
6 BHE 64-7	WINNER 4N2-14	100	80	2"½	1990	420	1355
6 BHE 64-8	WINNER 4N4-18	100	80	2"½	1990	420	1355
6 BHE 64-9	WINNER 4N4-18	100	80	2"½	1990	420	1355
86 BHE 77-2	IDROGO 40/08	125	100	80	2015	375	1370
86 BHE 77-3	IDROGO 40/12	125	100	80	2015	375	1370
86 BHE 77-4	IDROGO 40/15	125	100	80	2015	375	1370
86 BHE 77-5	WINNER 4N4-18	125	100	80	2015	375	1370
86 BHE 77-6	WINNER 4N4-18	125	100	80	2015	375	1370
86 BHE 95-2	IDROGO 40/08	125	100	80	2015	375	1370
86 BHE 95-3	IDROGO 40/12	125	100	80	2015	375	1370
86 BHE 95-4	WINNER 4N2-14	125	100	80	2015	375	1370
86 BHE 95-5	WINNER 4N4-18	125	100	80	2015	375	1370
86 BHE 95-6	WINNER 4N2-20	125	100	80	2015	375	1370

The contents of this publication should not be regarded as binding. EBARA Pumps Europe S.p.A. reserves the right to effect any modification it deems necessary, without prior notice.

## FIRE-FIGHTING UNITS WITH EXTERNAL PROTECTION R60

### STRUCTURAL SPECIFICATIONS

Exterior cases designed to house fire-extinguishing units compliant with Standards UNI EN 12845 and UNI 10779 are made in accordance with the structural and functional specifications set out in Standard UNI 11292. The protective cases are made from structures that are fire resistant for up to 60 minutes. They can be inspected from all sides in that they are equipped with REI60 doors and have light interior walls to improve brightness. The dimensions are sufficient to allow for the insertion/removal of the pumping unit parts. The protective cases are equipped with a natural ventilation system with shutters that open automatically by force of gravity equipped with protective grilles. The protective cases provide all the necessary properties to ensure both the management of the pumping unit during the operation of the fire-extinguishing system as well as routine and non-routine maintenance.

The protective cases have the following structural specifications:

- Load-bearing structure in electro-welded and coated section steel filled with mineral wool for fire-resistance R60;
- Smooth roof R60;
- R60 doors equipped with 180° hinges and locks with unique codes;
- Compartment for electrical panels and electrical equipment with concealed roof to protect against atmospheric agents;
- Base made from hot-galvanised electro-welded steel (to be built inside CCA frame to protect base);
- Hydraulic and electrical connections located on the bottom of the cabinet (floor outlets)
- Standard illumination for cabinet and electrical panel compartment (200lux) operational even in the event of mains power failure (25lux for 60 minutes);
- One single-phase 230V 50Hz power socket;
- Control electrical panel and protection for lighting and power sockets;
- Convector heater complete with environmental thermostat to maintain temperature above 15°C inside the cabinet;
- Ventilation system with shutters controlled by gravity with opposing protective grilles;
- Sprinkler system with flow switch and test valve for alarm (optional);
- Priming tanks located in the upper part already connected to the pumps anchored with galvanised and electro-welded section steel structure, as necessary for the overhead version;
- Gravity-operated shutter with protective grille and fan supplied directly from the diesel motor alternator, for forced ventilation (motor pumps only);
- Exhaust system with vibration-damping pipe, exhaust pipe and piping, protected in a thermally isolated compartment ventilated from the outside at half terminal with dual wall and rain guard (motor pumps only);
- Fuel tank with external pressure relief pipe and collection basin (dual chamber) for any diesel leaks (motor pumps only);
- Combined with electrical or diesel pumping units compliant with Standards UNI EN12845 and UNI 10779, connected to the structures via flexible supports and pipes with vibration-damping joints, electrically and hydraulically assembled and tested at the factory.

PHOTO OF FFBC 111 - OVERHEAD VERSION

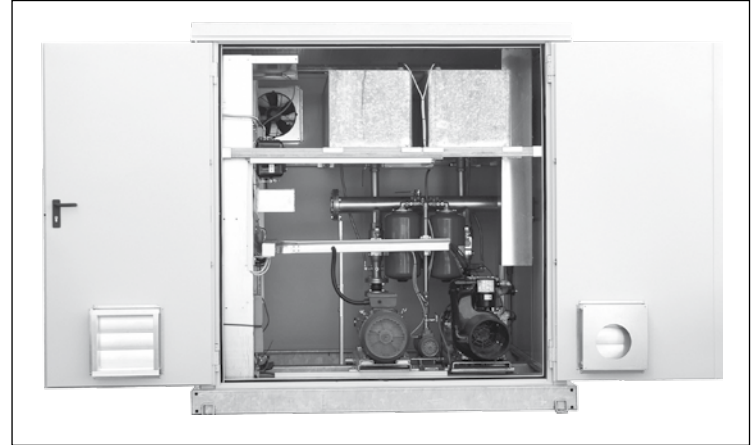
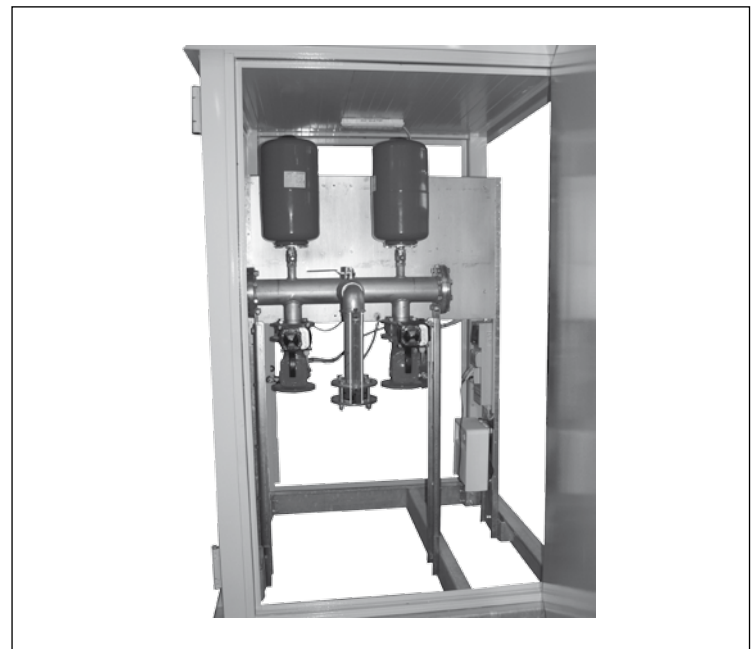

PHOTO OF FFBC 111 - UNDERHEAD VERSION



PHOTO OF FFBC 11S-FFBC 21S UNITS WITH SUBMERGED PUMPS



## FFP SERIES (MAIN PUMP FOR FFS UNITS)

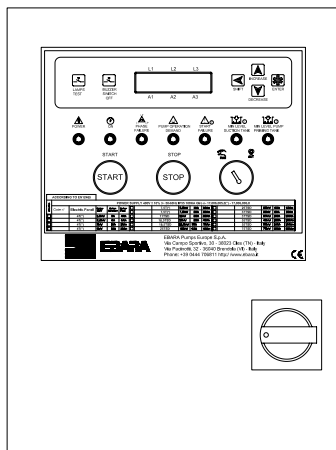

Control panels for fire-extinguishing units compliant with Standards UNI EN 12845 and UNI 10779.

Each panel is set up to control one electrical pump.

The panels are equipped with a circuit board that controls incorrect phase sequence, phase failure, undervoltage and measures the current taken up by the motor. There is also a terminal board for all electrical connections: pressure switches, external floats and notifications to be sent to the DFFRP control unit, installed in the supervised area.

These are set up for direct pump start-up for power ratings of up to 7.5 kW. Star delta starting is used for higher power ratings. They come complete with a graphic display for viewing system electrical parameters and menu settings.

The front of the panel features indicators lights for alarm signals in accordance with Standards UNI EN 12845 and UNI 10779. Fuses protecting the motor line and auxiliary lines and the phase failure monitoring device are housed inside.

Any faults in the relay and display circuit board DO NOT block the electrical pump start-up request in any way, both in the event of MANUAL or AUTOMATIC operation triggered by the pressure switches.

### FUNCTIONS

- Automatic or manual control of the supply pump
- Alarm signal with the ability for remote replication

### TECHNICAL DATA

- Door lock main disconnection switch
- Electrical pump control ON/OFF switch
- Pre-programmed electronic control unit for managing the electrical pump in accordance with Standards UNI EN 12845 and UNI 10779
- Pump in operation indicator
- Start-up request indicator
- Start-up failure indicator
- Power supply available indicator
- Phase/voltage failure indicator
- Lamp test button
- Manual start-up button
- Pump stop button
- Transformer for low voltage auxiliary circuit with protective fuses
- Start-up contactors (for direct start-up up to 7.5 kW. Star delta starting is used for higher power ratings.)
- High potential protective fuses for the passage of starting current for up to 20 seconds
- Terminal board for the connection of pressure switches and priming float
- Alarm output terminal board
- Set up in accordance with Standard UNI 10779
- Power supply: 400V  $\pm$ 10- 50/60 Hz
- Temperature limits: -10°C +40°C
- Protection rating IP55
- Reference standards: EN 60204-1, EN 60439-1, EN 61000-6-1, EN 61000-6-2, EN 61000-6-3, EN 61000-6-4, EN 60529, EN 12845

## FFJP SERIES (PILOT PUMP FOR FFS UNITS)

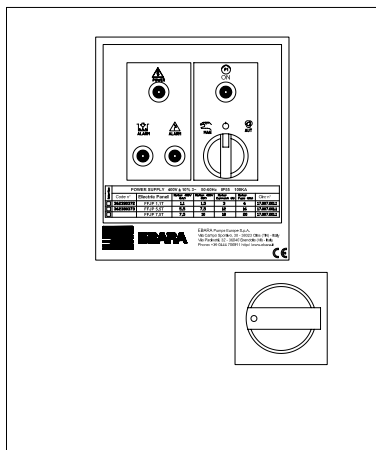

Control panels for fire-extinguishing units compliant with Standards UNI EN 12845 and UNI 10779 for electrical jockey pump

Each panel is set up to control one electrical pump.

- Operation is enabled by the minimum pressure level in the system, on the signal of a pressure switch. The pump is stopped automatically once the calibrated pressure is restored.
- The triggering of protection fuses FU1 on the motor line is signalled by the electronic relay which is triggered in the event of phase failure and indicated by an indicator light on the control panel and remotely.
- Motor overloading is monitored by the electronic relay and signalled by a lamp on the panel and remotely.

All protective devices (including the triggering of fuses FU2, FU3) are signalled remotely via contacts with no potential.

### TECHNICAL DATA

- "Clean" contacts for indicating pump operation and end block
- Set up for the connection of a float or minimum pressure switch to protect against dry operation
- Power supply: 400V  $\pm$ 10- 50/60 Hz
- Temperature limits: -10°C +40°C
- Protection rating IP55
- Reference standards: EN 60204-1, EN 60439-1, EN 61000-6-1, EN 61000-6-2, EN 61000-6-3, EN 61000-6-4, EN 60529, EN 12845

## FFSA SERIES (ACOUSTIC CONTROL UNIT ON-BOARD UNIT)

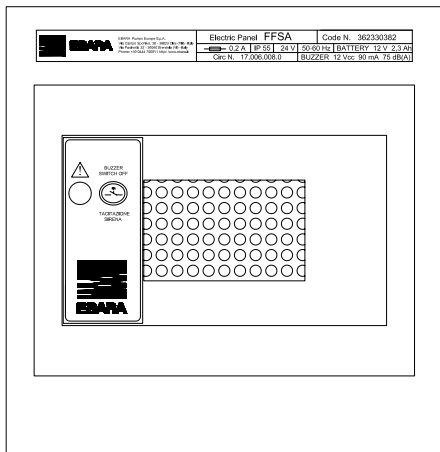

Acoustic signal control unit on board unit

The control unit is a piezoelectric two-tone siren with a battery-charging power supply unit and a 12 V d.c. battery. The control unit draws its power supply from the mains power supply at 230 V and is controlled by both panels on the SUPPLY pump and is activated in the following cases:

- SUPPLY pump operation request due to pressure drop in the system in the event of a fire
- Phase or power supply failure or incorrect phase at SUPPLY pump electrical panels
- Triggering of fuses protecting motor, auxiliary circuits, pump start-up failure, SUPPLY pump electrical panels
- Triggering of protective devices on JOCKEY pump electrical panel
- No water in the suction tanks

The control unit has a siren silencing button and a red LED for alarm signalling

In the event of a power supply failure the piezoelectric siren is activated and supplied autonomously by the battery for 20 hours of continuous operation.

### TECHNICAL DATA

- Power supply: 230  $\pm$ 10% - 50/60 Hz
- Temperature limits: -10°C +40°C
- Protection rating IP55
- Sound power level: 75 dB A
- Reference standards: EN 60204-1, EN 60439-1, EN 12845

## DFFRP SERIES (REMOTE CONTROL UNIT FOR MANNED AREA)

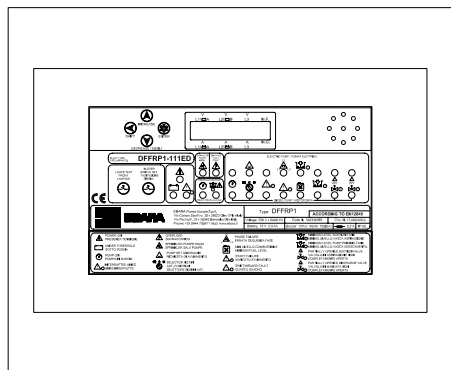

Digital remote control panel for monitoring alarms in the manned area to be connected to the electrical panels and micro switch contacts for the fire-extinguishing unit supply suction valves. Simultaneously manages the alarm signals from the two main pumps (electrical and/or diesel) as well as the jockey pump.

### FUNCTIONS

The control unit displays, monitors and signals alarms deriving from the fire-extinguishing unit on a display panel.

It includes a battery with a charge that lasts up to 20 hours to allow the alarm signals to operate in the event of a power failure.

Contacts are available for remote alarm signalling, for forwarding the same to a local or remote PC and for the connection of a GSM module (optional).

Communication with the electrical panels can be analogue (via cable connection) or digital via RS 485 connection (optional conversion module for FFB units).

### TECHNICAL DATA

- Power supply: 230  $\pm$ 10% - 50/60 Hz
- Temperature limits: -10°C +40°C
- Protection rating IP55
- Sound power level: 75 dB A
- Reference standards: EN 60204-1, EN 60439-1, EN 61000-6-1, EN 61000-6-2, EN 61000-6-3, EN 61000-6-4, EN 60529, EN 12845

## FFBP SERIES (MAIN PUMP FOR FFB UNITS)

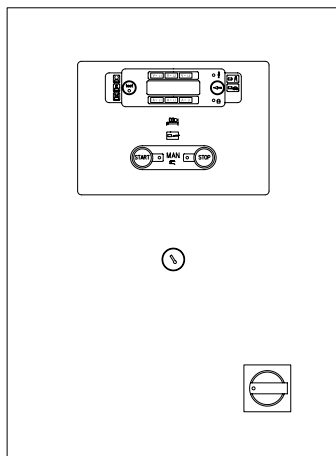

Control panels for fire-extinguishing units compliant with Standards UNI EN 12845 and UNI 10779.

Each panel is set up to control one electrical pump.

The electrical panels are equipped with a type CEA ELCOS electronic circuit board able to monitor and control the contactors for automatic start-up (start-up via pressure switch).

The presence of any alarms does not cause the pump to stop, they are indicated via the associated cumulative LED signal, a description on the display and they switch the contact for the remote control of the signal at the DFFRP control unit installed in the manned area.

These are set up for direct pump start-up for power ratings of up to 7.5 kW. Star delta starting is used for higher power ratings. They come complete with a graphic display for viewing system electrical parameters and menu settings.

The front of the panel features indicators lights for alarm signals in accordance with Standards UNI EN 12845 and UNI 10779. Fuses protecting the motor line and auxiliary lines and the phase failure monitoring device are housed inside.

### FUNCTIONS

- Automatic or manual control of the supply pump
- Alarm signal with the ability for remote replication

### TECHNICAL DATA

- Door lock main disconnection switch
- Electrical pump control ON/OFF switch
- Pre-programmed electronic control unit for managing the electrical pump in accordance with Standards UNI EN 12845 and UNI 10779
- Pump in operation indicator
- Start-up request indicator
- Start-up failure indicator
- Power supply available indicator
- Phase/voltage failure indicator
- Lamp test button
- Manual start-up button
- Pump stop button
- Transformer for low voltage auxiliary circuit with protective fuses
- Start-up contactors (for direct start-up up to 7.5 kW. Star delta starting is used for higher power ratings.)
- High potential protective fuses for the passage of starting current for up to 20 seconds
- Terminal board for the connection of pressure switches and priming float
- Alarm output terminal board
- Set up in accordance with Standard UNI 10779
- Power supply: 400V  $\pm 10\%$  50/60 Hz
- Temperature limits:  $-10^{\circ}\text{C}$   $+40^{\circ}\text{C}$
- Protection rating IP55
- Reference standards: EN 60204-1, EN 60439-1, EN 61000-6-1, EN 61000-6-2, EN 61000-6-3, EN 61000-6-4, EN 60529, EN 12845

## FFBM SERIES (MAIN MOTOR PUMP FOR FFB UNITS)

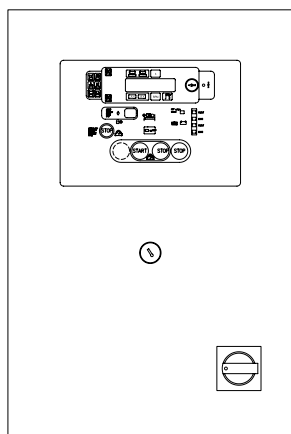

Control panels for fire-extinguishing units compliant with Standards UNI EN 12845 and UNI 10779.

Each panel is set up to control one motor pump.

The electrical panels are equipped with a type CEA ELCOS electronic circuit board able to monitor and control the contactors for automatic start-up (start-up via pressure switch).

The circuit board monitors the operating status of the motor pump via voltmeter for batteries A and B, ammeter for batteries A and B, hour meter, rev counter, fuel level indicator and oil thermometer.

The presence of any alarms does not cause the pump to stop, they are indicated via the associated cumulative LED signal, a description on the display and they switch the contact for the remote control of the signal at the DFFRP control unit installed in the manned area.

The electrical panel maintains the charge of batteries A and B using dedicated battery chargers installed inside it.

They come complete with a graphic display for viewing system electrical parameters and menu settings.

The front of the panel features indicators lights for alarm signals in accordance with Standards UNI EN 12845 and UNI 10779. Fuses protecting the motor line and auxiliary lines are housed inside.

### FUNCTIONS

- Automatic or manual control of the supply pump
- Alarm signal with the ability for remote replication

### TECHNICAL DATA

- Door lock main disconnection switch
- Motor pump control ON/OFF switch
- Pre-programmed electronic control unit for managing the motor pump in accordance with Standards UNI EN 12845 and UNI 10779
- Pump in operation indicator
- Start-up request indicator
- Start-up failure indicator
- Power supply available indicator
- Voltage failure signal
- Lamp test button
- Pair of buttons for emergency manual start-up from batteries
- Motor pump stop button
- 2 Battery chargers for charging and monitoring each battery
- Terminal board for the connection of pressure switches and priming float
- Alarm output terminal board
- Power supply: 230 single phase 50/60 Hz, 8-32 VDC
- Temperature limits: -10°C +50°C
- Protection rating IP55
- Reference standards: EN 60204-1, EN 60439-1, EN 61000-6-1, EN 61000-6-2, EN 61000-6-3, EN 61000-6-4, EN 60529, EN 12845

## FFBJP SERIES (PILOT PUMP FOR FFB UNITS)

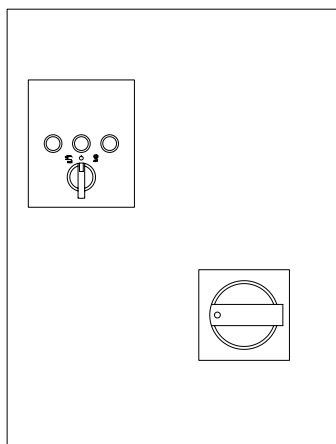

Control panels for fire-extinguishing units compliant with Standards UNI EN 12845 and UNI 10779 for electrical jockey pump

Each panel is set up to control one electrical pump.

- Operation is enabled by the minimum pressure level in the system, on the signal of a pressure switch. The pump is stopped automatically once the calibrated pressure is restored.
- The triggering of protection fuses FU1 on the motor line is signalled by the electronic relay which is triggered in the event of phase failure and indicated by an indicator light on the control panel and remotely.
- Motor overloading is monitored by the electronic relay and signalled by a lamp on the panel and remotely.

All protective devices (including the triggering of fuses FU2, FU3) are signalled remotely via contacts with no potential.

### TECHNICAL DATA

- Power supply: 400V  $\pm$ 10- 50/60 Hz
- Temperature limits: -10°C +40°C
- Protection rating IP55
- Reference standards: EN 60204-1, EN 60439-1, EN 61000-6-1, EN 61000-6-2, EN 61000-6-3, EN 61000-6-4, EN 60529, EN 12845

## PERFORMANCE SPECIFICATIONS

The specifications given refer to the curves provided in our catalogues and Data Books (see [www.ebara-europe.com](http://www.ebara-europe.com)). All performance curves are calculated in accordance with ISO 9906 Annex A.

Tolerances in accordance with ISO 9906 Annex A.

The curves refer to an effective asynchronous motor speed at 50 Hz.

The measurements were taken at a water temperature of 20°C and a kinematic viscosity of  $\nu = 1 \text{ mm}^2/\text{s}$  (1 cSt).

In order to avoid the risk of overheating, the pumps should not be used at a flow rate below 10% of the maximum flow rate.

Symbols: Q = Flow rate [ $\text{m}^3/\text{h}$ ]  
 H = Head [m]  
 P<sub>1</sub> = Power uptake from electrical line  
 P<sub>2</sub> = Power delivered at motor shaft (power uptake of pump)



# DNV BUSINESS ASSURANCE

## MANAGEMENT SYSTEM CERTIFICATE

---

*Certificato No. / Certificate No. CERT-17819-2006-AQ-VEN-SINCERT*

*Si attesta che / This is to certify that*

**EBARA PUMPS EUROPE S.p.A.**

*Sede e Stabilimento di Brendola: Via Pacinotti, 32 - 36040 Brendola (VI) - Italy*  
*Stabilimento di Cles: Via Campo Sportivo, 30 - 38023 Cles (TN) - Italy*  
*Filiale di Palermo: Via Don Luigi Sturzo, 181/183 - Z. I. - 90040 Carini (PA) - Italy*  
*Filiale di Cagliari: Via del Fangario, 29 - 09122 Cagliari (CA) - Italy*

*è conforme ai requisiti della norma per i sistemi di gestione:*  
*has been found to conform to the management system standard:*

**UNI EN ISO 9001:2008 (ISO 9001:2008)**

*Questa Certificazione è valida per il seguente campo applicativo:*  
*This Certificate is valid for the following product or service ranges:*

**Progettazione, produzione, vendita e commercializzazione di pompe e sistemi di pompaggio**  
**(Settore EA : 18 - 17)**

*Design, manufacture, sales and trade of pumps and pumping systems*  
**(Sector EA : 18 - 17)**

*Data Prima Emissione/Initial Certification Date:*  
**2006-10-13**

---

*Il Certificato è valido fino al:*  
*This Certificate is valid until:*  
**2015-10-10**

---

*L'audit è stato eseguito sotto la supervisione di*  
*The audit has been performed under the supervision of*

---

**Michele Gaiba**  
*Lead Auditor*



SSQ N°023 A    PRD N°003 B  
 SGA N°023 D    SGL N°002 G  
 SCR N°024 F    FSA N°001 I

Membro di NQA RA per gli schemi di accreditamento ISO, SGA, PRD, PDS, SSP e LSA di NQA RA per gli schemi di accreditamento ISO, SGA, SGL, FSA e PRD e di NQA ELAC per gli schemi di accreditamento LAB

*Luogo e Data/Place and Date:*  
**Agrate Brianza (MB), 2012-10-02**

---

*Per l'Organismo di Certificazione:*  
*For the Accredited Unit:*



---

**Zeno Beltrami**  
*Management Representative*

La validità del presente Certificato è subordinata al rispetto delle condizioni contenute nel Contratto di Certificazione.  
 Lack of fulfilment of conditions as set out in the Certification Agreement may render this Certificate invalid.

DET NORRØD VERITAS ITALIA SRL - CENTRO DIRIZIONALE COLLEONI - PALAZZO SIBO - V.LE COLLEONI, 9 - 20864 AGRATE BRIANZA (MB) - ITALY - TEL. 039 48 99 905 - WWW.DNVBA.COM/IT

