

### PRESSURE BOOSTING



Units with three vertical multistage pumps.

#### PUMP FEATURES

#### FIELD OF USE

- Maximum working pressure: 11 bar
- Maximum temperature of the liquid: 40°C

#### MATERIALS

- Cast iron pump body and motor support
- External casing in AISI 304
- Impeller and nozzle in PPE+PS reinforced with fibreglass
- Shaft in AISI 416

#### TECHNICAL DATA

- Self-ventilated 2 pole asynchronous motor
- Class of insulation F
- IP44 Protection rating
- 230V  $\pm 10\%$ , 50Hz single phase voltage, 230/400V  $\pm 10\%$ , 50Hz three phase voltage
- Permanent capacitor inserted and thermo-amperometric protection with automatic reset incorporated for the single phase motor

#### TYPICAL APPLICATIONS

The base of the group is in galvanised steel as are the manifolds. The discharge manifold is set-up to gather any three vertical type membrane reservoirs. Three pressure switches, the electric control panel and a pressure gauge are mounted on it. On suction, each electric pump has an isolating valve and a non-return valve, with the possibility of connection to an air supply unit and has another isolating valve in discharge mode.

#### Protection and control panel with CE mark

- IMQ and VDE marked components
- Very low voltage auxiliary circuit
- Motor switch-on and switch-off are controlled by two pressure switches
- The connection to a float of minimum pressure pressure switch is possible in order to prevent functioning in conditions when there is no suction water
- A device is present that inverts the insertion order of the pumps at every start-up
- Power supply:
  - 230V, 50Hz single phase
  - 400V, 50 Hz three phase
- Direct start-up
- Power circuit protection fuse
- Auxiliary circuit protection fuse
- Protection rating IP 55
- Line general isolating switch with door lock
- Aut. - 0 - man. switches for each pump
- Circuit breaker protection reset
- LED indicator:
  - network presence
  - motor running
  - level alarm
  - motor in protection mode (for three phase version only)
- Alarm output set-up
- On request, special version control panels can be used

#### FUNCTIONING PRINCIPLES

The withdrawal or however the escape of water from the system with the pumps at a standstill, causes the pressure to drop and the consequent closure of the pressure switch contact with highest calibration, which determines start-up of the first electric pump. If the outlet discharge exceeds the flow rate of a pump, the pressure continues to drop until it causes the closure of the contact of the second pressure switch and the start-up of the second pump. The end of the distribution of the reduction of the outlet discharge leads to the pressure in the system rising, with opening of the pressure switch contacts and staggered pumps stops. The inversion of the ignition order of the two motors reduces the number of hourly start-ups of the individual pumps and consequently allows a homogenous use of the same. By connecting a float or minimum pressure pressure switch to the control panel (whether for withdrawal from the primary collection reservoir or from the hydraulic circuit), the most frequent cause of electric pump breakdown is prevented: the lack of water at suction.

### PRESSURE BOOSTING

#### 3GP CVM A 8 range PERFORMANCE CURVES

(according to ISO 9906 Attachment A)

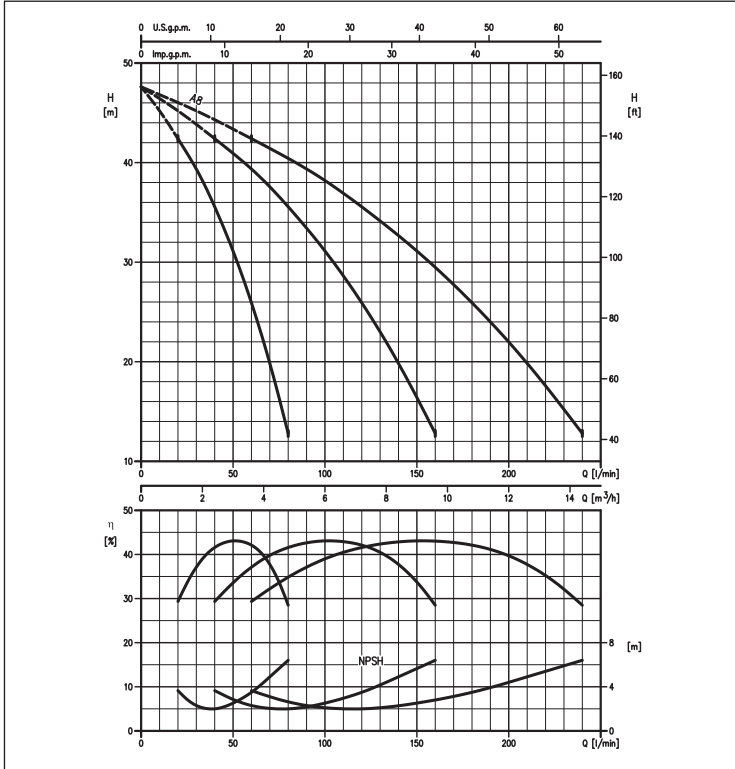

#### 3GP CVM A 10 - A 12 - A 15 range PERFORMANCE CURVES

(according to ISO 9906 Attachment A)

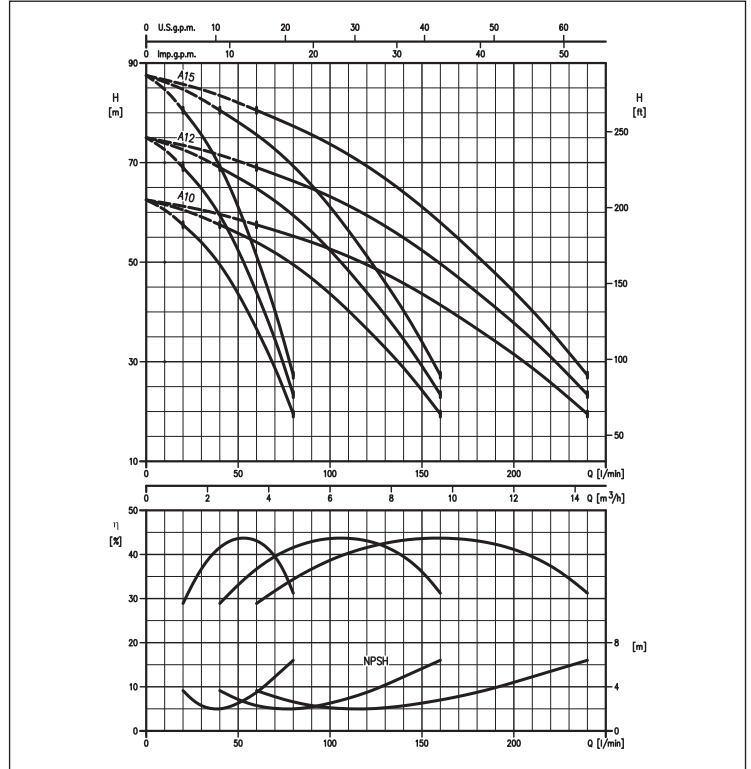

#### 3GP CVM A 18 range PERFORMANCE CURVES

(according to ISO 9906 Attachment A)

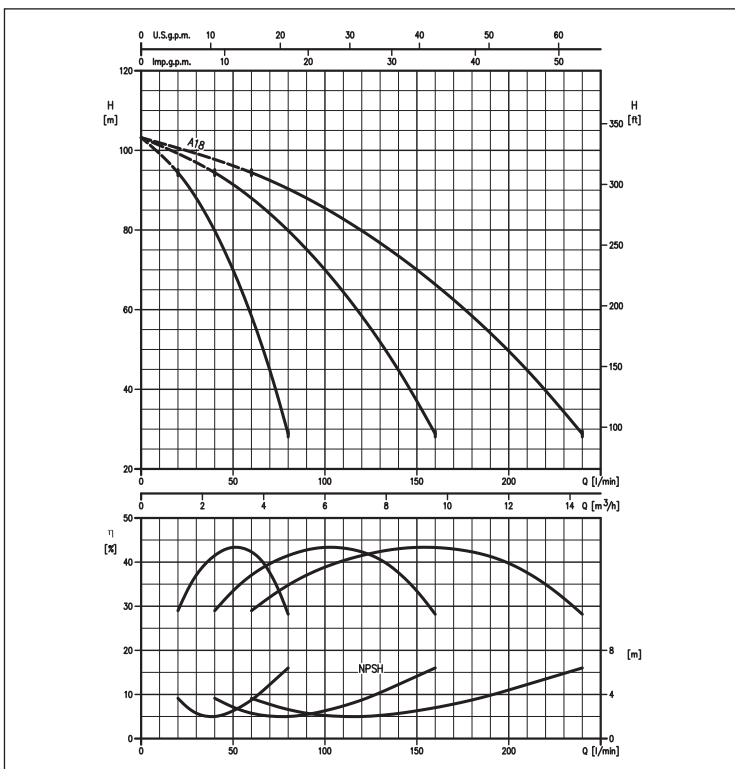

### PRESSURE BOOSTING

#### 3GP CVM B 10 - B 12 - B 15 range PERFORMANCE CURVES

(according to ISO 9906 Attachment A)

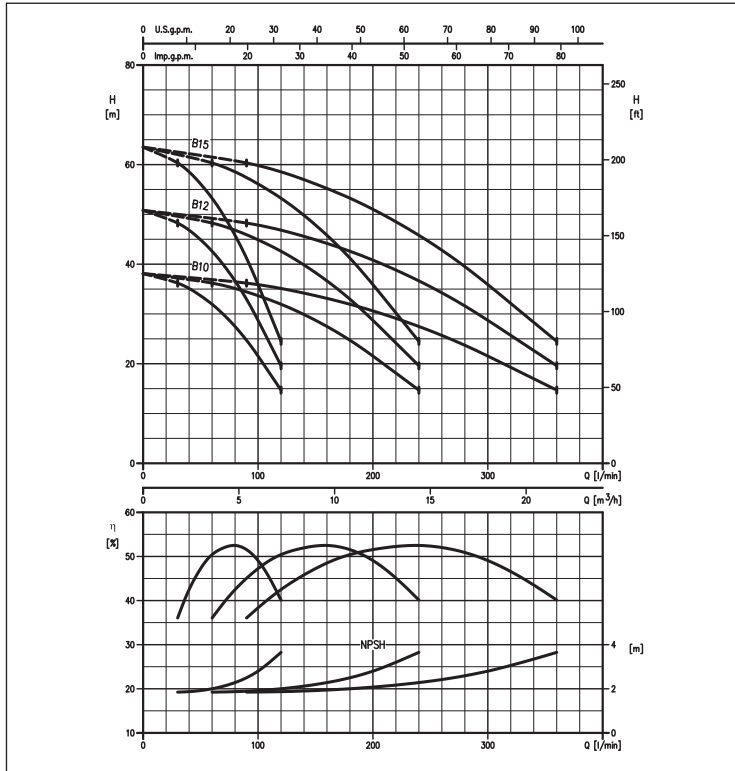

#### 3GP CVM B 20 - B 23 - B 25 range PERFORMANCE CURVES

(according to ISO 9906 Attachment A)

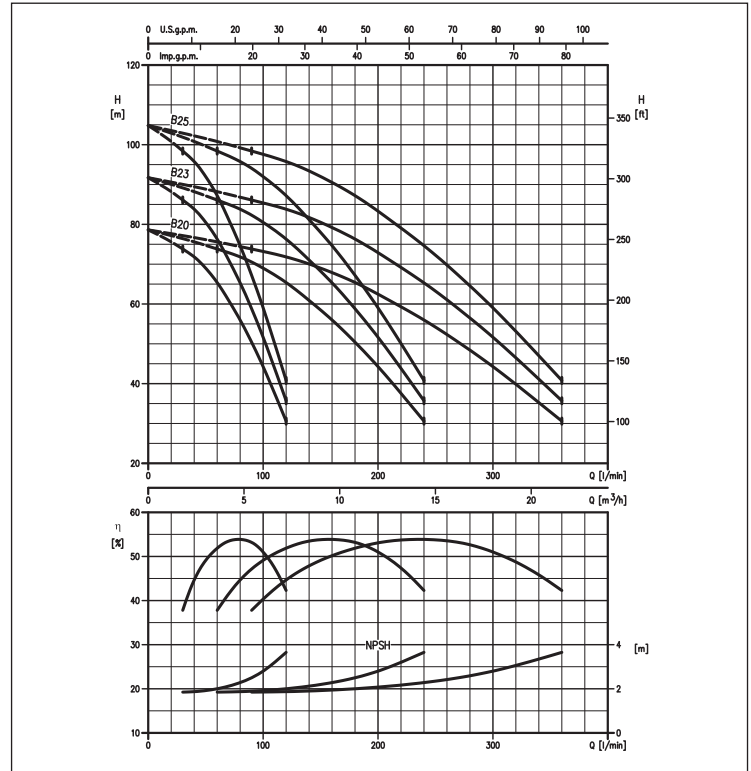

#### PERFORMANCE TABLE AND ELECTRIC DATA OF THE TWO PUMPS FUNCTIONING SIMULTANEOUSLY

Model	[kW]	Max. abs. [A]	Q=Flow rate								
			l/min	60	90	120	150	180	240	300	360
			m³/h	3,6	5,4	7,2	9	10,8	14,4	18	21,6
				H=Head [m]							
CVM A/8	0,6+0,6+0,6	4,8	-	42,5	39,4	35,6	31,1	25,9	12,8	-	-
CVM A/10	0,75+0,75+0,75	6,9	-	57,5	54,0	49,5	43,5	36,6	19,5	-	-
CVM A/12	0,9+0,9+0,9	8,4	-	69,0	65,0	59,5	52,5	44,0	23,4	-	-
CVM A/15	1,1+1,1+1,1	9,9	-	80,5	75,5	69,5	61,0	51,0	27,3	-	-
CVM A/18	1,3+1,3+1,3	9,3	-	94,5	88,0	80,0	70,0	58,5	28,8	-	-
CVM B/10	0,75+0,75+0,75	7,2	-	36,2	35,1	33,7	33,7	32,0	27,5	21,6	14,7
CVM B/12	0,9+0,9+0,9	8,1	-	48,0	46,8	45,0	45,0	42,6	36,6	28,8	19,6
CVM B/15	1,1+1,1+1,1	9,6	-	60,5	58,5	56,2	56,2	53,3	45,8	36,0	24,5
CVM B/20	1,5+1,5+1,5	9,9	-	74,0	72,0	69,0	69,0	65,5	56,0	44,5	30,6
CVM B/23	1,7+1,7+1,7	12,9	-	86,0	84,0	80,5	80,5	76,5	65,5	51,5	35,7
CVM B/25	1,85+1,85+1,85	12,9	-	98,5	96,0	92,0	92,0	87,0	74,5	59,0	41,0

### PRESSURE BOOSTING

#### DIMENSIONS

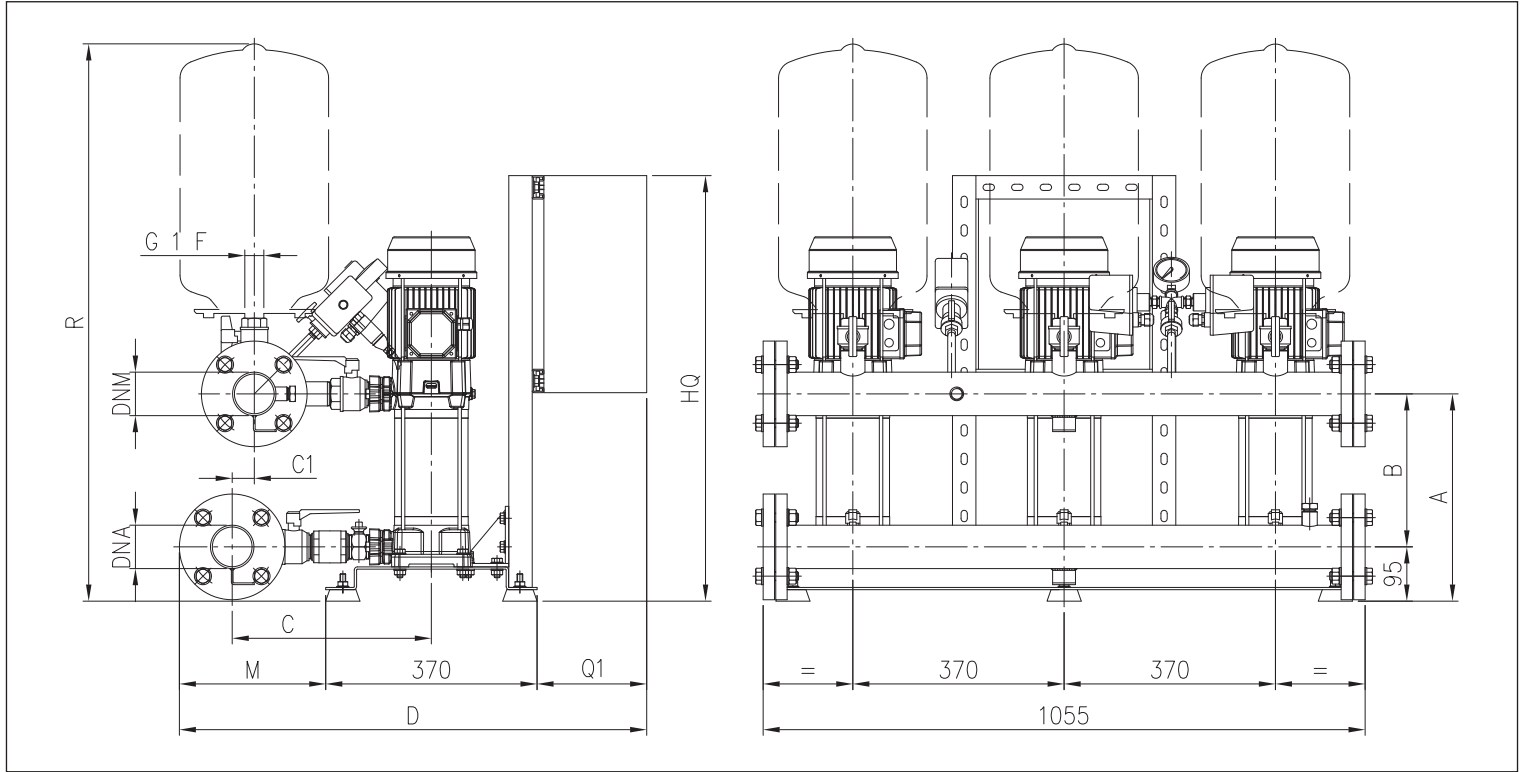

#### DIMENSIONS TABLE

Model	Dimensions [mm]											Weight [kg]
	A	B	C	C1	D	M	R	HQ	Q1	DNA	DNM	
3GP CVM A/8	260	165	460	150	925	365	870	745	190	DN65	DN65	115,0
3GP CVM A/10	285	190	350	40	815	255	895	745	190	DN65	DN65	127,0
3GP CVM A/12	310	215	350	40	815	255	920	745	190	DN65	DN65	130,0
3GP CVM A/15	335	240	350	40	815	255	945	745	190	DN65	DN65	133,0
3GP CVM A/18	365	270	350	40	815	255	975	745	190	DN65	DN65	141,0
3GP CVM B/10	235	140	460	150	925	365	845	745	190	DN65	DN65	125,0
3GP CVM B/12	260	165	460	150	925	365	870	745	190	DN65	DN65	127,0
3GP CVM B/15	285	190	350	40	815	255	895	745	190	DN65	DN65	131,0
3GP CVM B/20	310	215	350	40	815	255	920	745	190	DN65	DN65	141,0
3GP CVM B/23	335	240	350	40	815	255	945	745	190	DN65	DN65	145,0
3GP CVM B/25	365	270	350	40	815	255	975	745	190	DN65	DN65	148,0