

Inverter controlled units with two vertical multistage pumps with stainless steel hydraulic parts.

PUMP FEATURES

FIELD OF USE

- Maximum working pressure: 10 bar
- Maximum temperature of the liquid: 90°C

MATERIALS

- Cast iron pump body
- External casing, impellers, intermediate stage, seal housing disc and shaft in AISI 304
- Mechanical seal in Carbon/Ceramic/NBR

TECHNICAL DATA

- T.E.F.C. 2 pole motor
- Class of insulation F
- IP55 Protection rating
- 230V $\pm 10\%$, 50Hz single phase voltage, 230/400V $\pm 10\%$, 50Hz three phase voltage
- Permanent capacitor inserted and thermo-amperometric protection with automatic reset incorporated for the single phase motor
- Circuit breaker protection under user's responsibility for the three phase version

TYPICAL APPLICATIONS

The base of the group is in galvanised steel as are the manifolds. The discharge manifold is set-up to gather any three vertical type membrane reservoirs. Three pressure switches and a pressure gauge are mounted on it. On suction, each electric pump has an isolating valve and a non-return valve, with the possibility of connection to an air supply unit and has another isolating valve in discharge mode. The electric control panel is sustained by a relative support fixed to the base.

Protection and control panel with CE mark

- IMQ and VDE marked components
- Very low voltage auxiliary circuit
- Motor switch-on and switch-off are controlled by three pressure switches
- The connection to a float of minimum pressure pressure switch is possible in order to prevent functioning in conditions when there is no suction water
- A device is present that inverts the insertion order of the pumps at every start-up
- 400V, 50 Hz three phase power supply
- Start-up:
 - direct for powers up to 7.5 kW
 - delta/triangle for powers exceeding 7.5 kW
- Power circuit protection fuse
- Auxiliary circuit protection fuse
- Protection rating IP 55
- Line general isolating switch with door lock
- Aut. - 0 - man. switches for each pump
- Circuit breaker protection reset
- LED indicator:
 - network presence
 - motor running
 - level alarm
 - motor in protection mode
- Alarm output set-up
- On request, special version control panels can be used

FUNCTIONING PRINCIPLES

The withdrawal or however the escape of water from the system with the pumps at a standstill, causes the pressure to drop and the consequent closure of the pressure switch contact with highest calibration, which determines start-up of the first electric pump. If the outlet discharge exceeds the flow rate of this pump, the pressure continues to drop until it causes the closure of the contact of the second pressure switch and any third pressure switch and the start-up of another or another two main pumps. The end of the distribution of the reduction of the outlet discharge leads to the pressure in the system rising, with opening of the pressure switch contacts and staggered pumps stops. The inversion of the ignition order of the motors reduces the number of hourly start-ups of the individual pumps and consequently allows a homogenous use of the same. By connecting a float or minimum pressure pressure switch to the control panel (whether for withdrawal from the primary collection reservoir or from the hydraulic circuit), the most frequent cause of electric pump breakdown is prevented: the lack of water at suction.

3GP 3M 32 RANGE PERFORMANCE CURVE (according to ISO 9906 Attachment A)

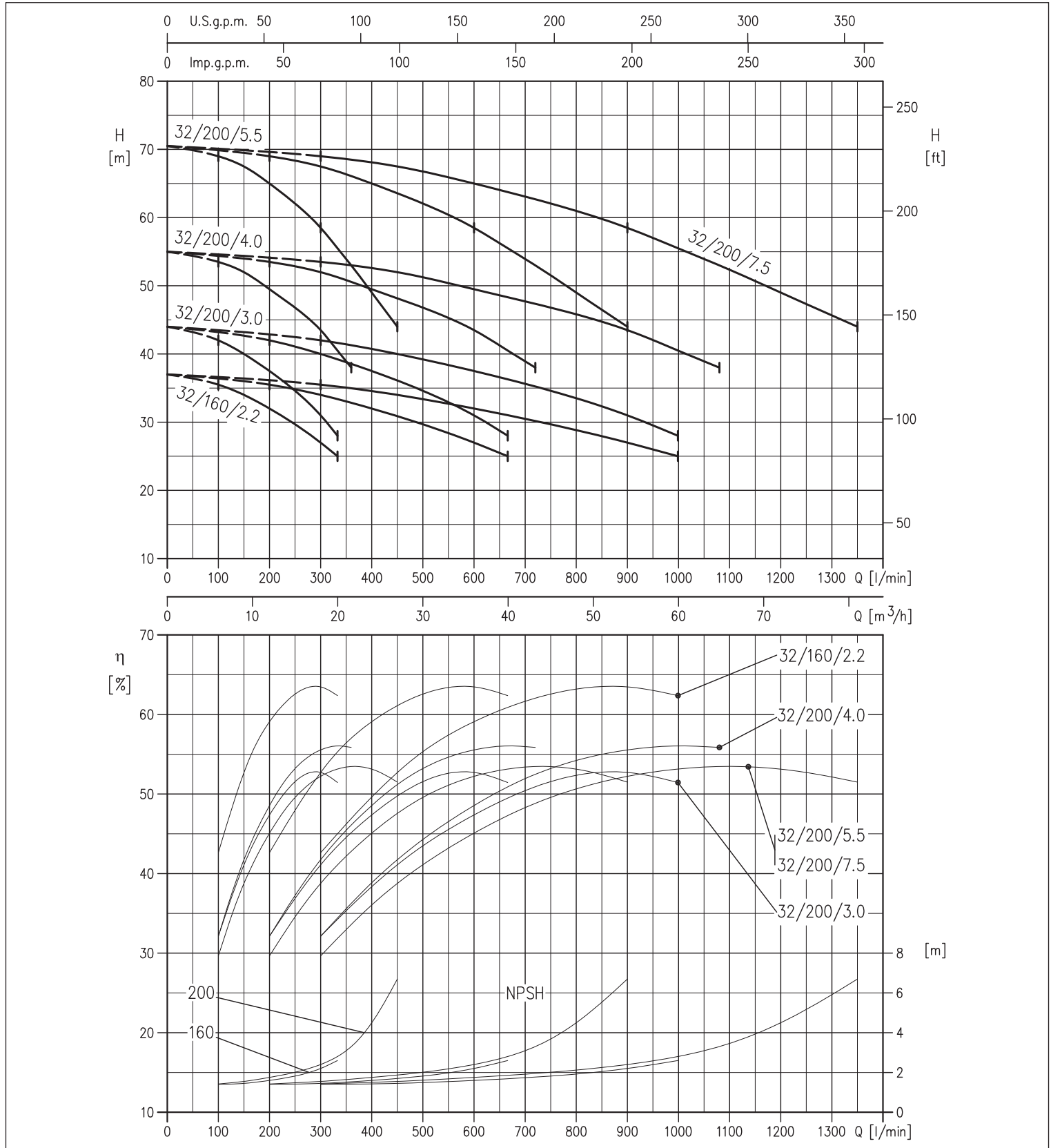

3GP 3M 40 RANGE PERFORMANCE CURVE (according to ISO 9906 Attachment A)

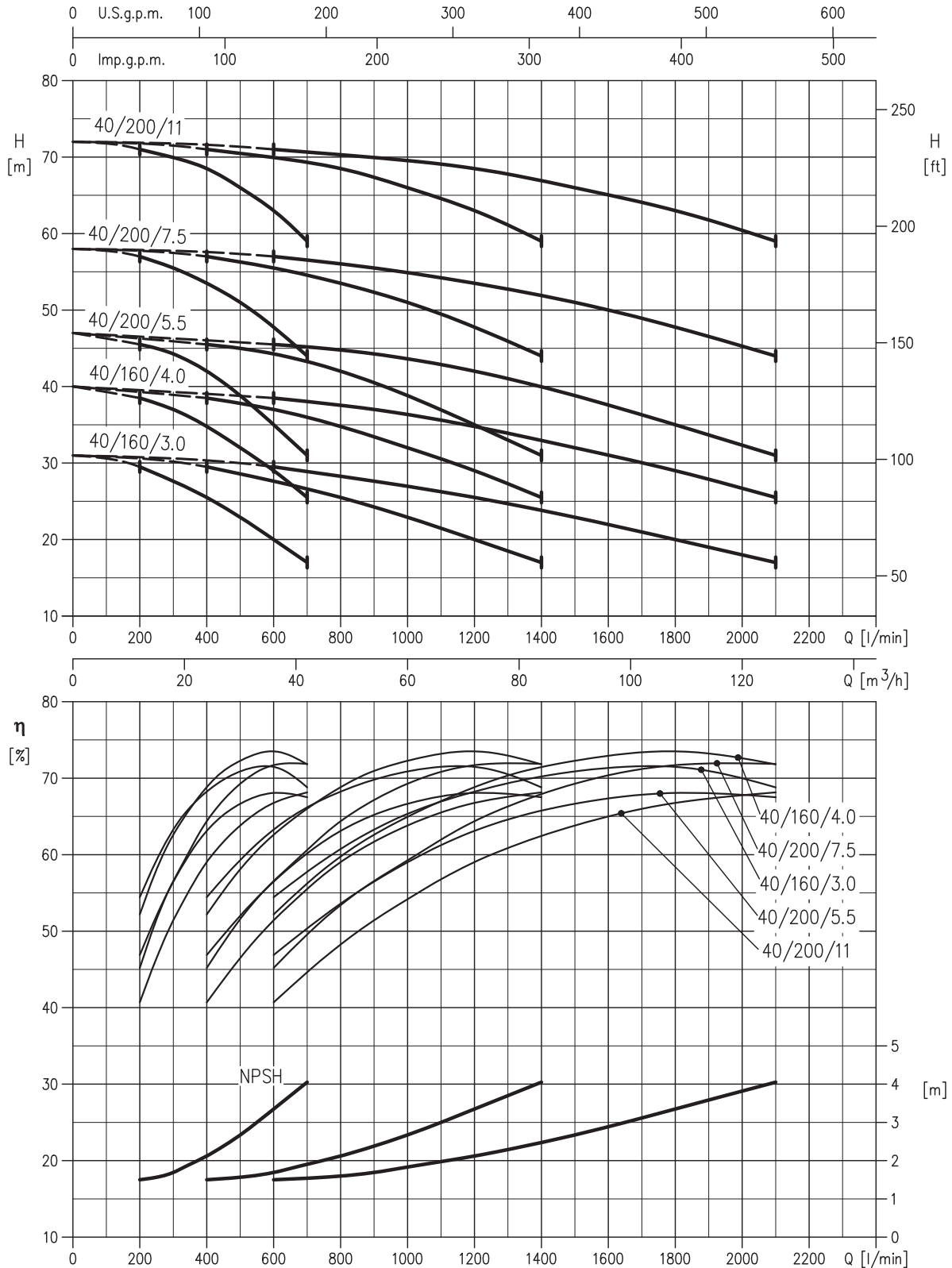

3GP 3M 50 RANGE PERFORMANCE CURVE (according to ISO 9906 Attachment A)

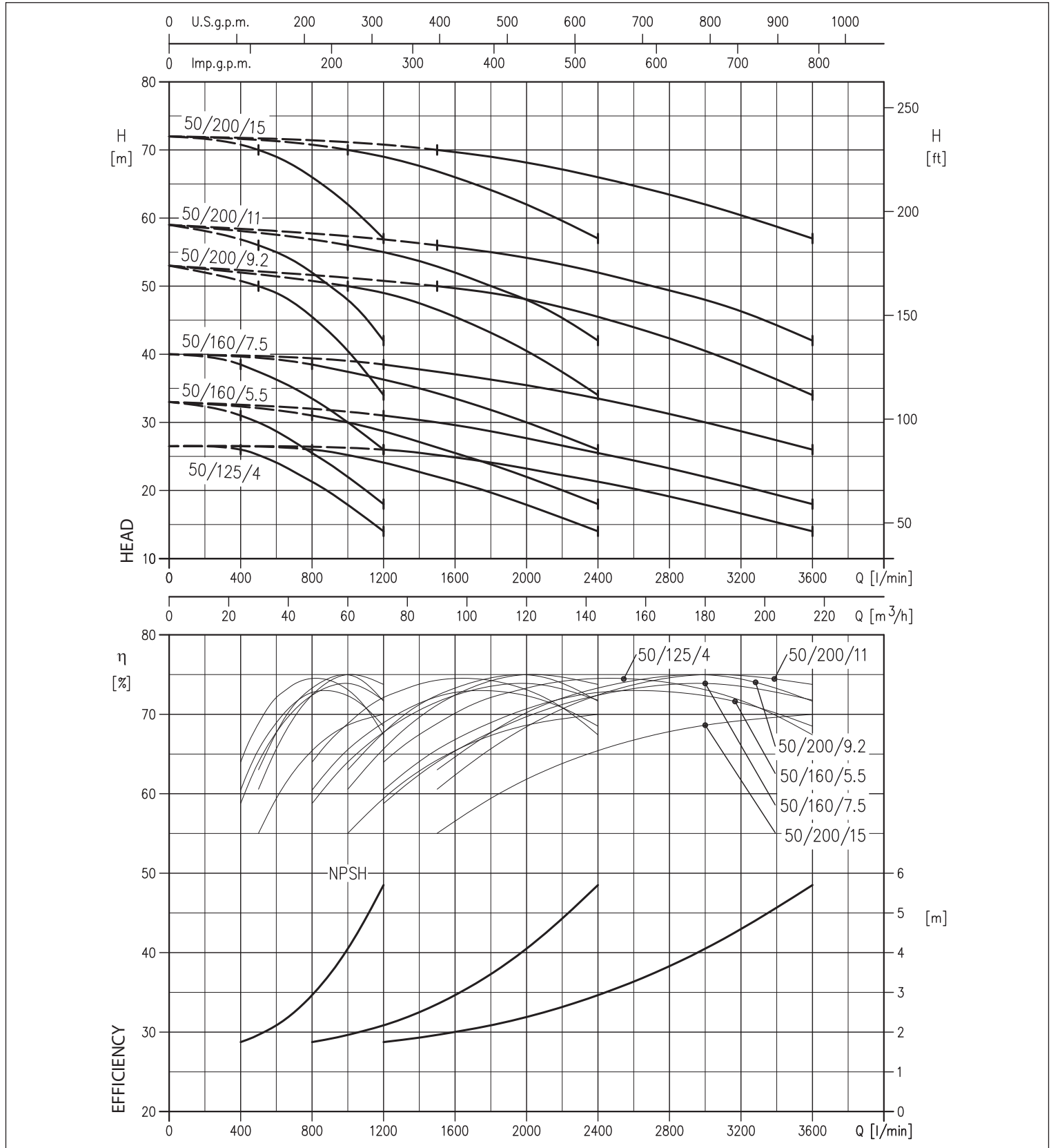

3GP 3M 65 RANGE PERFORMANCE CURVE (according to ISO 9906 Attachment A)

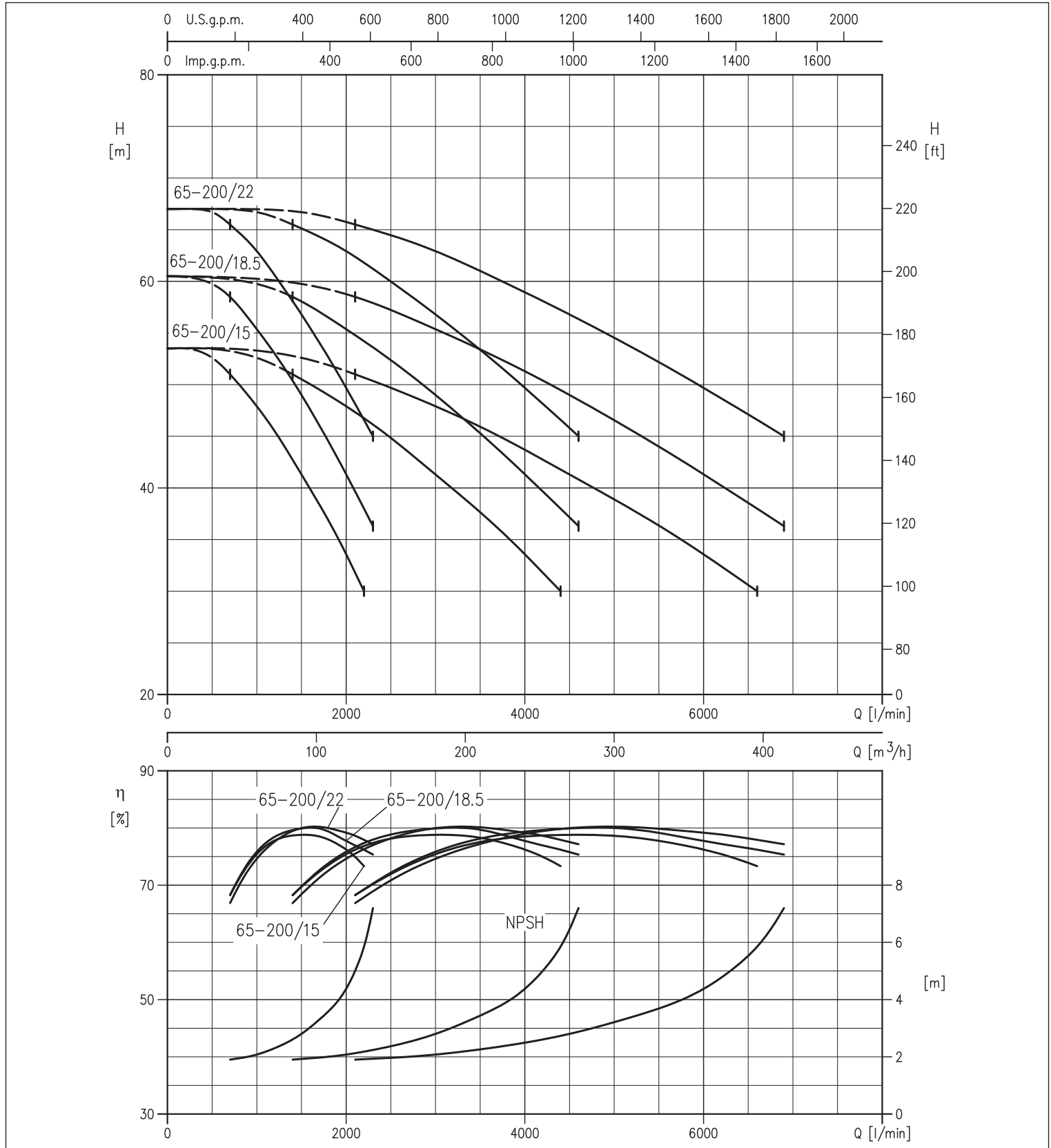

PERFORMANCE TABLE AND ELECTRIC DATA OF THE THREE PUMPS FUNCTIONING SIMULTANEOUSLY

Model Three phase 400V	[kW]	Max abs. [A] 400V Three phase	Q=Flow rate														
			l/min	300	450	600	900	1000	1080	1200	1350	1500	1800	2100	2400	3000	3600
			m ³ /h	9	27	36	54	60	65	72	81	90	108	126	144	180	216
			H=Head [m]														
3M 32-160/2,2	2,2+2,2+2,2	14,4	35,5	34,0	32,0	27,0	25,0	-	-	-	-	-	-	-	-	-	-
3M 32-200/3,0	3+3+3	19,5	42,0	40,0	37,5	31,0	28,0	-	-	-	-	-	-	-	-	-	-
3M 32-200/4,0	4+4+4	27,6	53,5	52,0	49,5	43,5	40,5	38,0	-	-	-	-	-	-	-	-	-
3M 32-200/5,5	5,5+5,5+5,5	35,4	69,0	67,5	65,0	58,5	-	-	-	-	-	-	-	-	-	-	-
3M 32-200/7,5	7,5+7,5	47,1	69,0	67,5	65,0	58,5	55,5	53,0	49,0	44,0	-	-	-	-	-	-	-
3M 40-160/3,0	3+3+3	19,5	-	-	29,5	27,5	27,0	26,5	25,5	24,0	22,5	20,0	17,0	-	-	-	-
3M 40-160/4,0	4+4+4	27,6	-	-	38,5	37,0	36,0	35,5	34,5	33,0	32,0	29,0	25,5	-	-	-	-
3M 40-200/5,5	5,5+5,5+5,5	35,4	-	-	45,5	44,0	43,0	42,5	41,0	39,5	38,0	35,0	31,0	-	-	-	-
3M 40-200/7,5	7,5+7,5+7,5	47,1	-	-	57,0	55,5	55,0	54,5	53,5	52,5	51,0	47,5	44,0	-	-	-	-
3M 40-200/11	11+11+11	66	-	-	71,0	70,5	70,0	69,5	68,5	67,5	66,0	63,0	59,0	-	-	-	-
3M 50-125/4	4+4+4	27,6	-	-	-	-	-	-	26,0	25,5	25,0	24,0	22,5	21,5	17,9	14,0	-
3M 50-160/5,5	5,5+5,5+5,5	35,4	-	-	-	-	-	-	31,0	30,5	30,0	28,5	27,0	25,5	22,0	18,0	-
3M 50-160/7,5	7,5+7,5+7,5	47,1	-	-	-	-	-	-	38,5	38,0	37,5	36,0	35,0	33,5	30,0	26,0	-
3M 50-200/9,2	9,2+9,2+9,2	56,4	-	-	-	-	-	-	-	-	50,0	49,0	47,5	45,5	40,5	34,0	-
3M 50-200/11	11+11+11	66	-	-	-	-	-	-	-	-	56,0	55,0	54,0	52,0	48,0	42,0	-
3M 50-200/15	15+15+15	90	-	-	-	-	-	-	-	-	70,0	69,0	68,0	66,0	62,0	57,0	-

Model Three phase 400V	[kW]	Max abs. [A] 400V Three phase	Q=Flow rate									
			l/min	2100	2700	3900	4500	5100	5700	6300	6600	6900
			m ³ /h	126	162	234	270	306	342	378	396	414
			H=Head [m]									
3M 65-200/15	15+15+15	90	51,0	49,0	44,0	41,5	38,4	35,3	31,8	30,0	-	-
3M 65-200/18,5	18,5+18,5+18,5	117	58,5	56,5	51,5	49,0	46,0	43,0	39,7	38,0	36,3	-
3M 65-200/22	22+22+22	127	65,5	64,0	59,5	57,0	54,0	51,0	48,0	46,5	45,0	-

3GP 3M DIMENSIONS

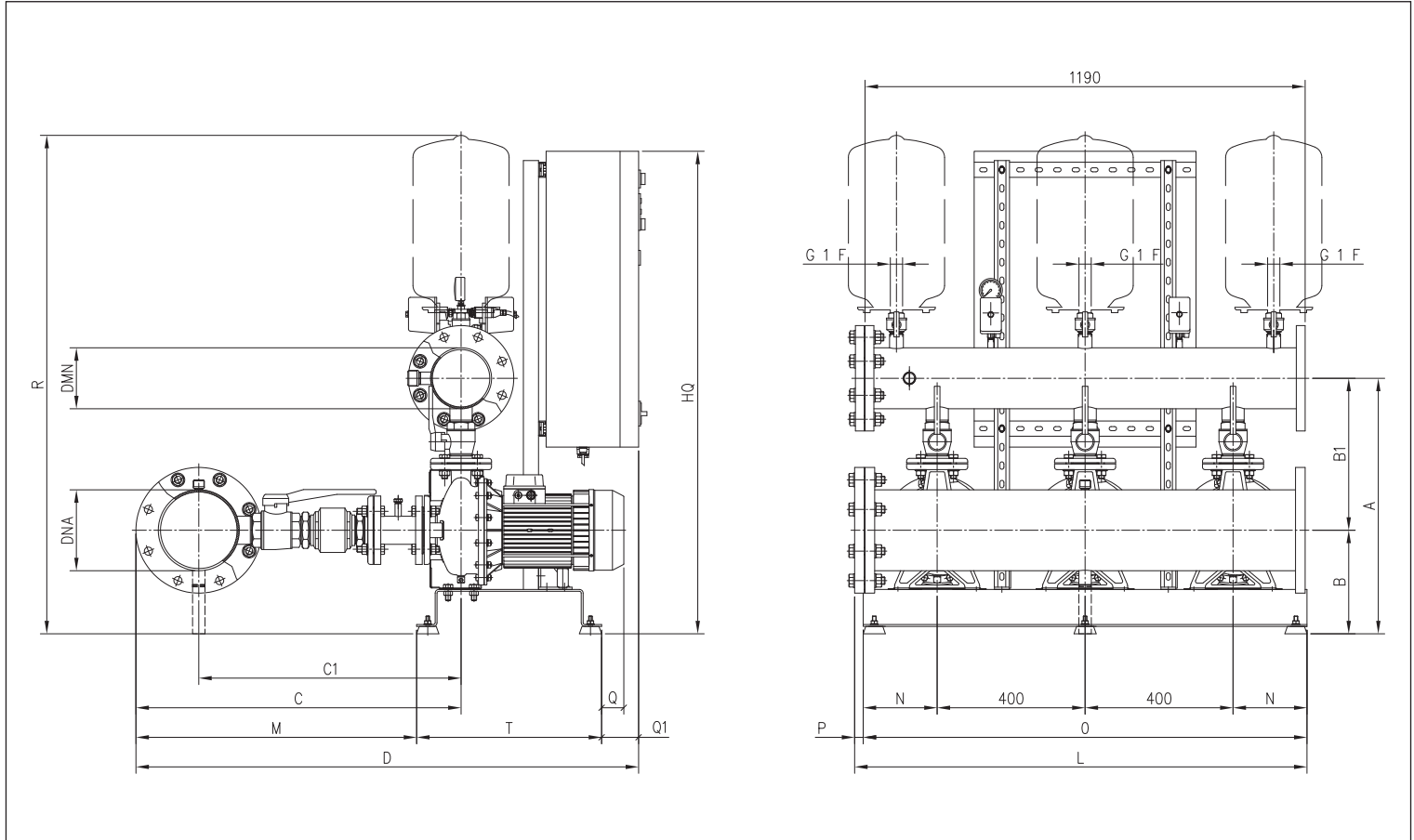

DIMENSIONS TABLE

Model	Dimensions [mm]																		Weight [kg]
	A	B	B1	C	C1	D	DNA	DNM	HQ	L	M	N	O	P	Q	Q1	R	T	
3GP 3M 32-160/2.2	570	250	320	455	390	880	100	80	985	1215	340	200	1200	15	-	40	1190	500	164,0
3GP 3M 32-200/3	620	280	340	455	390	880	100	80	985	1215	340	200	1200	15	-	40	1240	500	187,0
3GP 3M 32-200/4	620	280	340	455	390	880	100	80	985	1215	340	200	1200	15	-	40	1240	500	209,0
3GP 3M 32-200/5.5	620	280	340	455	390	880	100	80	985	1215	340	200	1200	15	-	40	1240	500	243,0
3GP 3M 32-200/7.5	620	280	340	455	390	880	100	80	985	1215	340	200	1200	15	-	40	1240	500	243,0
3GP 3M 40-160/3	615	250	365	920	780	1340	150	125	985	1220	810	200	1200	20	-	30	1260	500	274,0
3GP 3M 40-160/4	615	250	365	920	780	1340	150	125	985	1220	810	200	1200	20	-	30	1260	500	295,0
3GP 3M 40-200/5.5	665	280	385	940	800	1360	150	125	985	1220	820	200	1200	20	15	40	1310	500	370,0
3GP 3M 40-200/7.5	665	280	385	940	800	1410	150	125	985	1220	820	200	1200	20	60	90	1310	500	392,0
3GP 3M 40-200/11	630	245	385	940	800	1505	150	125	1180	1380	705	290	1380	-	-	-	1275	800	427,0
3GP 3M 50-125/4	645	250	390	880	710	1290	200	150	985	1225	760	200	1200	25	-	30	1300	500	370,0
3GP 3M 50-160/5.5	690	280	410	880	710	1320	200	150	985	1225	760	200	1200	25	18	30	1350	500	403,0
3GP 3M 50-160/7.5	690	280	410	880	710	1320	200	150	985	1225	760	200	1200	25	60	30	1350	500	421,0
3GP 3M 50-200/9.2	675	245	430	880	710	1595	200	150	1230	1380	765	290	1380	-	-	-	1335	800	434,0
3GP 3M 50-200/11	675	245	430	880	710	1595	200	150	1230	1380	765	290	1380	-	-	-	1335	800	452,0
3GP 3M 50-200/15	675	245	430	880	710	1595	200	150	1230	1380	765	290	1380	-	-	-	1335	800	538,0
3GP 3M 65-200/15	950	265	685	1055	855	1755	250	200	1250	1380	955	290	1380	-	-	-	1635	800	580,0
3GP 3M 65-200/18.5	950	265	685	1055	855	1755	250	200	1250	1380	955	290	1380	-	-	-	1635	800	606,0