

PRESSURE BOOSTING



Units with two horizontal multistage pumps.

PUMP FEATURES

FIELD OF USE

- Maximum working pressure: 10 bar
- Maximum temperature of the liquid: 40°C

MATERIALS

- Cast iron pump body and support
- External casing in AISI 304
- Technopolymer impeller and nozzle
- Shaft in AISI 416

TECHNICAL DATA

- Self-ventilated 2 pole asynchronous motor
- Class of insulation F
- IP44 Protection rating
- 230V $\pm 10\%$, 50Hz single phase voltage, 230/400V $\pm 10\%$, 50Hz three phase voltage
- Permanent capacitor inserted and thermo-amperometric protection with automatic reset incorporated for the single phase motor
- Protection under user's responsibility for the three phase version

TYPICAL APPLICATIONS

The base of the group is in galvanised steel as are the manifolds. The discharge manifold is set-up to gather any two vertical type membrane reservoirs. Two pressure switches, the electric control panel and a pressure gauge are mounted on it. On suction, each electric pump has an isolating valve and a non-return valve, with the possibility of connection to an air supply unit and has another isolating valve in discharge mode.

Protection and control panel with CE mark

- IMQ and VDE marked components
- Very low voltage auxiliary circuit
- Motor switch-on and switch-off are controlled by two pressure switches
- The connection to a float of minimum pressure pressure switch is possible in order to prevent functioning in conditions when there is no suction water
- A device is present that inverts the insertion order of the pumps at every start-up
- Power supply:
 - 230V, 50Hz single phase
 - 400V, 50 Hz three phase
- Direct start-up
- Power circuit protection fuse
- Auxiliary circuit protection fuse
- Protection rating IP 55
- Line general isolating switch with door lock
- Aut. - 0 - man. switches for each pump
- Circuit breaker protection reset
- LED indicator:
 - network presence
 - motor running
 - level alarm
 - motor in protection mode (for three phase version only)
- Alarm output set-up
- On request, special version control panels can be used

FUNCTIONING PRINCIPLES

The withdrawal or however the escape of water from the system with the pumps at a standstill, causes the pressure to drop and the consequent closure of the pressure switch contact with highest calibration, which determines start-up of the first electric pump. If the outlet discharge exceeds the flow rate of a pump, the pressure continues to drop until it causes the closure of the contact of the second pressure switch and the start-up of the second pump. The end of the distribution of the reduction of the outlet discharge leads to the pressure in the system rising, with opening of the pressure switch contacts and staggered pumps stops. The inversion of the ignition order of the two motors reduces the number of hourly start-ups of the individual pumps and consequently allows a homogenous use of the same. By connecting a float or minimum pressure pressure switch to the control panel (whether for withdrawal from the primary collection reservoir or from the hydraulic circuit), the most frequent cause of electric pump breakdown is prevented: the lack of water at suction.

2GP COMPACT A range PERFORMANCE CURVES

(according to ISO 9906 Attachment A)

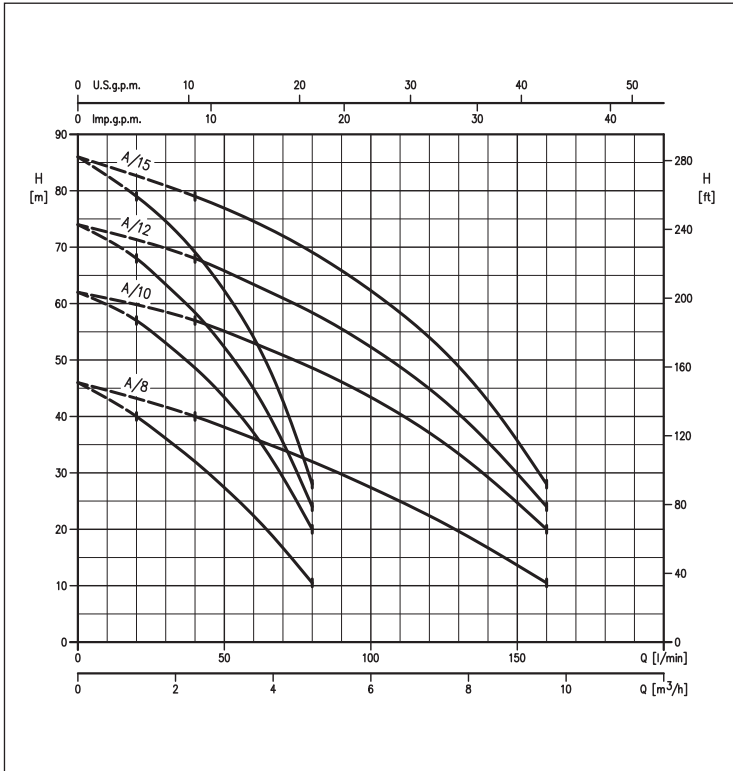

2GP COMPACT B range PERFORMANCE CURVES

(according to ISO 9906 Attachment A)

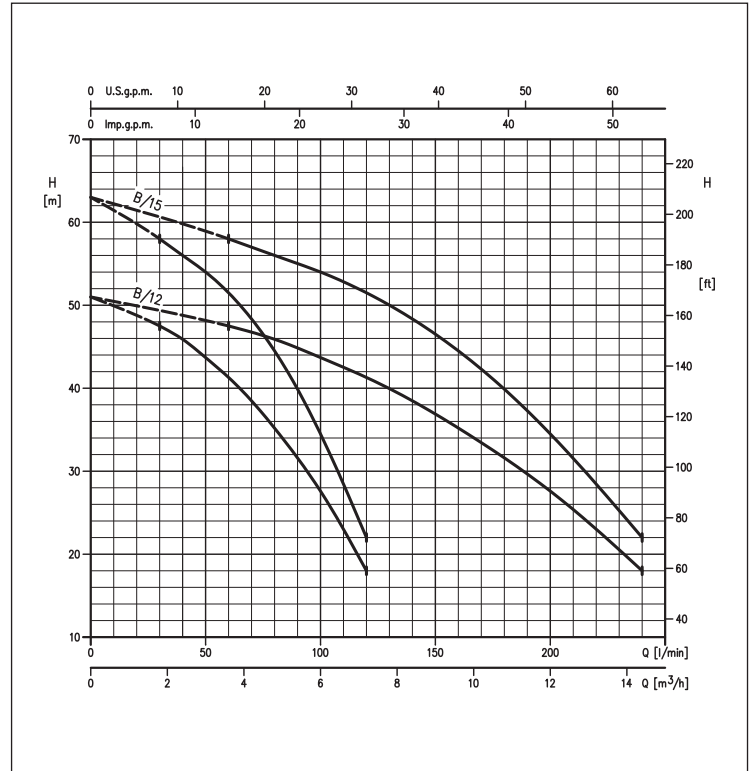

PERFORMANCE TABLE AND ELECTRIC DATA OF THE TWO PUMPS FUNCTIONING SIMULTANEOUSLY

Model	230V single phase	400V three-phase	Max absorption [kW]	Max absorption [A]		Q=Flow rate							
				230V single phase	400V three-phase	l/min	40	80	120	160	200	240	
						m³/h	2,4	4,8	7,2	9,6	12	14,4	
							H=Head [m]						
COMPACT AM 8	COMPACT A 8	0,60 + 0,6	8	3	39,7	32,0	22,4	10,5	-	-	-	-	
COMPACT AM 10	COMPACT A 10	0,75 + 0,75	12	4,8	56,5	48,6	37,1	20,0	-	-	-	-	
COMPACT AM 12	COMPACT A 12	0,88 + 0,88	12,4	5,4	67,5	58,4	44,9	24,0	-	-	-	-	
COMPACT AM 15	COMPACT A 15	1,1 + 1,1	14,6	6,6	79,0	69,1	54,0	28,0	-	-	-	-	
COMPACT BM 12	COMPACT B 12	0,88 + 0,88	11,6	5,4	-	45,9	41,3	35,2	27,6	18,0	-	-	
COMPACT BM 15	COMPACT B 15	1,1 + 1,1	14,6	6,8	-	56,0	51,5	44,5	34,5	22,0	-	-	

DIMENSIONS

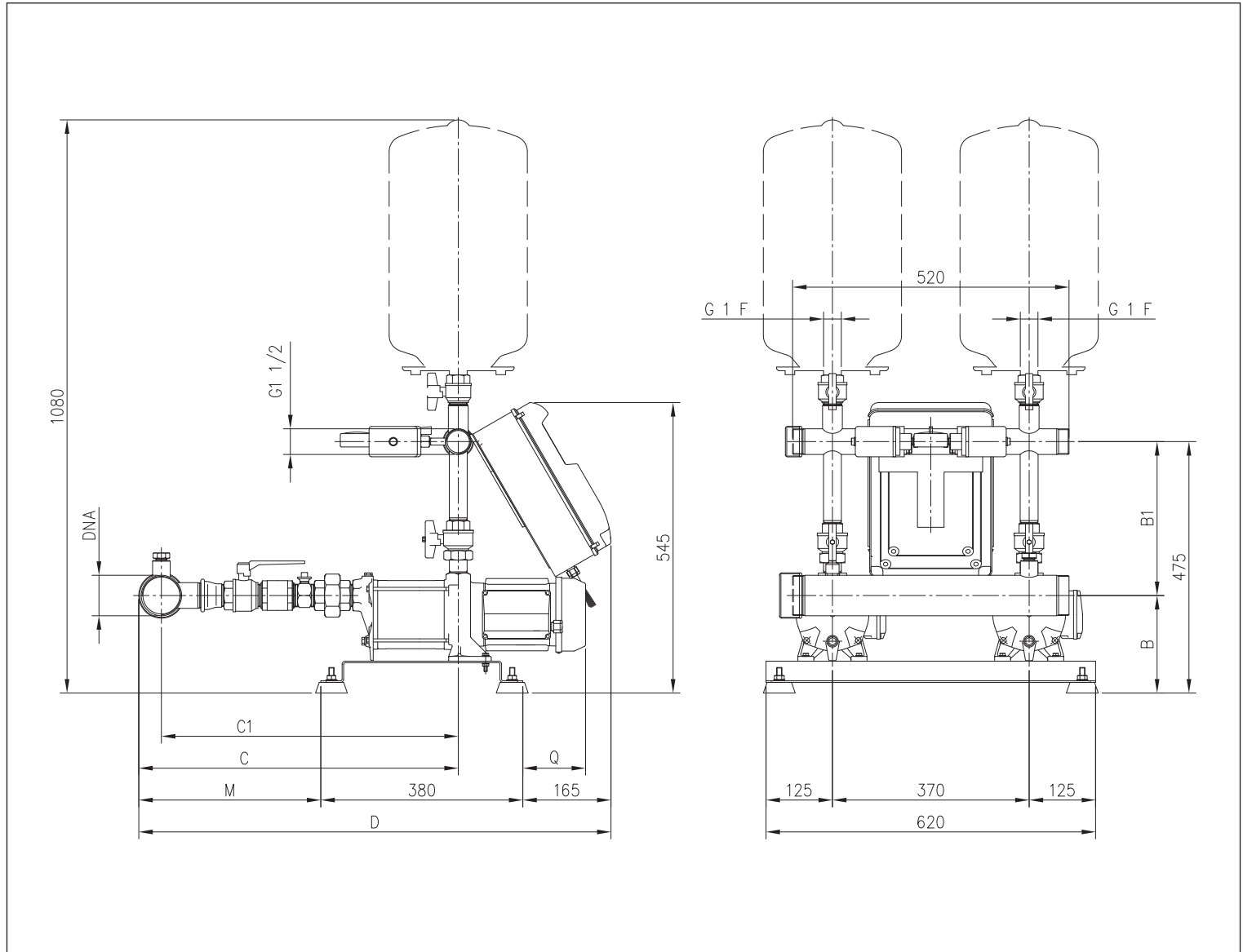

DIMENSIONS TABLE

Model	Dimensions [mm]					DNA	M	Q	Weight [kg]
	B	B1	C	C1	D				
2GP COMPACT A(M)8	190	285	525	490	815	G2	270	65	52,0
2GP COMPACT A(M)10	185	290	555	520	840	G2	295	105	61,0
2GP COMPACT A(M)12	185	290	580	545	865	G2	320	105	63,0
2GP COMPACT A(M)15	185	290	605	570	890	G2	345	120	65,0
2GP COMPACT B(M)12	185	290	575	530	860	G2½	315	105	64,0
2GP COMPACT B(M)15	185	290	600	560	890	G2½	345	120	66,0