

## G200 F HP 6,5

Motor benzinski



Nazivna snaga	<b>4,1 kW</b> 3600 rpm	Kapacitet ulja	<b>0,6 l.</b>
Max. okretni moment	<b>12,4 Nm</b> 2500 rpm	Razina buke	<b>70 db (A)</b>
Paljenje	<b>Ručno</b>	Provrt i hod	<b>68 x 54 mm</b>
Zapremnina	<b>196 cc</b>	Dimenzije (D X Š X V)	<b>312 x 376 x 335 mm</b>
Spremnik goriva	<b>3,6 l.</b>	Masa	<b>16 Kg</b>

Jedan cilindar , prisilno zračno hlađenje , 4- taktni

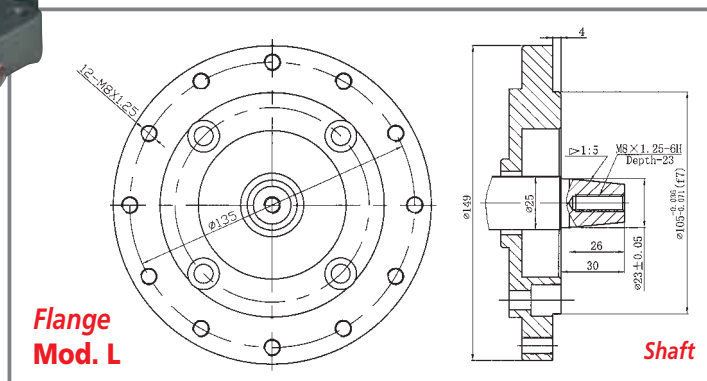

## G200 F - L HP 6,5

Motor benzinski



Nazivna snaga	<b>4,1 kW</b> 3600 rpm	Kapacitet ulja	<b>0,6 l.</b>
Max. okretni moment	<b>12,4 Nm</b> 2500 rpm	Razina buke	<b>70 db (A)</b>
Paljenje	<b>Ručno</b>	Provrt i hod	<b>68 x 54 mm</b>
Zapremnina	<b>196 cc</b>	Dimenzije (D X Š X V)	<b>312 x 376 x 335 mm</b>
Spremnik goriva	<b>3,6 l.</b>	Masa	<b>16 Kg</b>

Jedan cilindar , prisilno zračno hlađenje , 4- taktni